

CMB Meeting Minutes #179

DATE: July 24, 2014

MEETING DATE: **July 23, 2014**

LOCATION: 821 Howard St, Main Conference Room

TIME: 3:00 PM

ATTENDEES: J Funghi (JF), R. Redmond (RR), (ML), M. Kobler, (MK) J. Park (JP), B. Lebovitz (BL), A. Hoe (AH), J. Wang (JW), E. Stassevitch (ES), L. Zurinaga (LZ), B. Ward (BW),

COPIES TO: Attendees: S. Farhangi (SF), M. Henry (MH), M. Vilcheck, (MV), M. Latch (MK), A. Clifford (AC), M. Acosta (MA), K. Shah (KS), R. Nguyen (RN), S Tisell (ST), J. Xia (JX), V. Chow (VC), S. Jefferis (SJ), S. Espinal (SE), R. Hansen (RH), D. Kuehn (DK)
File No. M544.1.5.0890

REFERENCE Project No. M544.1, Contract No. 149 Task 1-8.02

SUBJECT: Configuration Management Board Meeting # 179 – Rev. No. 0

RECORD OF MEETING *(Italicized text indicates status update of open items)*

ITEM #	DISCUSSION	ACTION BY DUE DATE
1-	1300 - J. Wang presented PCC 013 - UMS Relocation of traffic signal Controller Cabinet. The proposed work would relocate the traffic signal cabinet at the NE corner of Geary and Stockton Streets to the NW corner. This item was previously presented to the CMB and recommended at the time, to leave the signal cabinet at its current location. However, BSM has gone through the public notification process approving the new location and permits have been approved. The Board agreed to send the PCC to the Contractor for a price quote, cautioning the estimated value of \$22,000K could be considerably higher due to unforeseen work, taken into consideration the amount of conduit congestion in the area. The Board requested JW to present for review the PCC related to STS - relocation of communication and electrical cabinets at 4th and Brannan Streets.	JW 08/13/14
2-	1300 - R. Redmond and M. Kobler presented for consideration; draft diagrams to evaluate and respond to the Contractor's preliminary request of variance in the sequential excavation method (SEM) work at Chinatown station prior to sending an official submittal (see attached). The CMB reviewed the Contractor's sequencing diagrams which appear to deviate from the contract drawings. The Board directed the RE to forward the document to the design engineer of record for the comments.	
3-	CN1300 Trend Report for the week of 07/23/14 was reviewed. Changes were made to the report's layout showing all current trends in numeric order and identifying related PCC or COR numbers if applicable. The Board took no exception to the updated format, suggested the report should include a title in the document header and revision to the first column's header to say "trend number".	

ACTION ITEMS

ITEM #	MTG DATE	MTG ACTION DATE	DESCRIPTION	BIC	DUE DATE	STATUS
8	07/24/13	07/24/13	1252 – Breakdown of Bid Item GE-3	AC/Mle	07/30/14	Open
2	08/14/13	08/14/13	1252 – CMod #8 (PSI strength) – Statement of occurrence post meeting record of approval which overrode CMB direction	AC/Mle	07/30/14	Open
2 & 3	08/28/13	08/28/13	1252 – COR 97 & 98 – gravel encountered action plan from Engineering of Record (DP1)	AC/Mle	07/30/14	Open
5	09/25/13	10/02/13	1300 – PCC CTS 0001 - Contractor Cost Proposal	MK	07/30/14	Open
2	10/09/13	10/09/13	1252 – Design Clause - confirmation of existing contract language in CN 1252 and CN 1300 regarding existing conditions related to utilities	JW/AH	07/30/14	Open
1	10/16/13	10/16/13	1252 – COR 102 - Determine if the Contractor received 1251 as built information before they began operations	AC/Mle	07/30/14	Open
1	10/16/13	10/16/13	1252 – COR 102 - Graphic showing the location of the headwalls control line	AC/Mle	07/30/14	Open
3	10/23/13	10/23/13	1252 – PCC 014 - Contractor Cost Proposal	JW/AC	07/30/14	Open
2	11/06/13	11/06/13	1252 - COR 017 – Notify utility of cost as Form B bill update under CN1250 or CN1251	AC/Mle	07/30/14	Open
2	11/13/13	11/13/13	1300 – Setup a meeting with DT to confirm the use to control traffic	VC	07/30/14	Open
NA	11/13/13	11/13/13	1252 – Confirm who is being billed for the use of PCO's at 5 th St.	AC/Mle	07/30/14	Open
2	11/20/13	11/20/13	1300 – PCC 00X - PGE Traffic Control - Utility verification letter	MK	07/30/14	Open
9	12/11/13	12/11/13	1252 - Trend Log Segment Measuring Frequency line item credit (1.3M)	AC/Mle	07/30/14	Open
2	01/08/14	01/08/14	1300 - PCC - Contractor Cost Proposal - Geoprobos	RR/ST	07/30/14	Open
4	01/08/14	01/08/14	1300 - PCC - Contractor Cost Proposal - Joint Trench Conduits	MK	07/30/14	Open
4	01/15/14	01/15/14	1300 - CTS confirmation from PG&E of cost for concrete encasement of lines	MK	07/30/14	Open
1	07/02/14	07/02/14	1300 - STS PCC 006 AT&T Addl Vaults and Ductbank - written agreement of cost & reimbursement to CSP	MA	07/30/14	Open
1	07/23/14	07/23/14	1300 - STS PCC - Reloc. of Comm. & Elect. Cabinets - Ref NC-1	JW	08/13/14	Open

Meeting adjourned at 4:55pm

These meeting minutes have been prepared by B. Ward and reviewed by E. Stassevitch, and are the preparer's interpretation of discussions that took place. If the reader's interpretation differs, please contact the author in writing within four (4) days of receipt of these minutes.

Signed:  [initials of preparer & reviewer] Date: 24 Jul 14 [Date review completed]

Meeting Agenda

Project No. M544.1, Contract No. CS-149
Program/Construction Management
Configuration Management Board (CMB) Meeting No. 179
July 23, 2014
3:00pm – 5:00pm
Central Subway Project Office
821 Howard St. 2nd Floor
Main Conference Room

Attendees:

John Funghi		Brad Lebovitz		Luis Zurinaga	
Albert Hoe		Roger Nguyen			
Mark Latch		Richard Redmond			
Eric Stassevitch		Beverly Ward			

1. **1300** - UMS PCC 013 - Relocation of Traffic Signal Controller Cabinet at Geary & Stockton St. - *Approval*
- CTS Sequencing for SEM work- *Informational*
2. **Trend Log** -
3. **Other Business** -



Connecting people. Connecting communities.

Meeting Attendance Sheet

Project No. M544.1, Contract No. 149
Program/Construction Management
Configuration Management Board Special Meeting No. 179
July 23, 2014
3:00 p.m. – 5:00 p.m.
 Central Subway Project Office
 821 Howard, 2nd Floor
 Main Conference Room

Deliver Meeting Attendance Sheet with original signatures/initials to Document Control.

NAME	AFFILIATION	PHONE	E-MAIL (for minutes)	INITIALS
Please enter initials if your name is listed below. Please enter name, affiliation, phone number and email address if your name is not listed below.				
Acosta, Mike	SFMTA	(415) 701-5282	Mike.Acosta@sfmta.com	
Chow, Vivian	SFMTA	(415) 701-5264	Vivian.chow@sfmta.com	
Clifford, Alex	CSP	(415) 243-0953	Alex.Clifford@sfmta.com	
Farhangi, Shahnam	SFMTA	(415) 554-0721	Shahnam.Farhangi@sfmta.com	
Funghi, John	SFMTA	(415) 701-4299	John.Funghi@sfmta.com	<i>JS</i>
Haley, John	SFMTA		John.Haley@sfmta.com	
Henry, Melvyn	SFMTA	(415) 701-5719	Melvyn.Henry@sfmta.com	
Hoe, Albert	SFMTA	(415) 701-4289	Albert.Hoe@sfmta.com	<i>AH</i>
Jefferis, Scott	SFMTA	(415) 238-4679	Richard.Jefferis@sfmta.com	
Kelly, Jim	SFMTA		Jim.Kelly@sfmta.com	
Kobler, Mike	CSP	(415) 850-4750	Mike.kobler@sfmta.com	<i>MK</i>
Kuehn, David	STV/PMOC	(510) 464-8053	David.kuehn@stvinc.com	
Latch, Mark	CSP	(415) 701-5294	Mark.Latch@sfmta.com	
Lebovitz, Brad	STV/PMOC	(510) 464-8052	Bradley.lebovitz@stvinc.com	<i>BL</i>
Nguyen, Roger	SFMTA	(415) 701-4312	Roger.Nguyen@sfmta.com	



Municipal Transportation Agency



PCC Estimate:

Relocation of Traffic Signal Controller Cabinet at Geary & Stockton St.

Engineer's Estimate

Contract No. 1300 - UMS

12/23/13 REV.01

1. General Scope:

The scope of work includes installation of additional PVC & GRSC conduits and wires associated with the relocation of the traffic controller cabinet from the northeast corner of Geary & Stockton Streets to the Northwest corner of Geary & Stockton Streets.

The first concrete duct bank is 30 feet long & contains two 2" PVC SCH 80 conduits & one 3" PVC SCH 80 conduit encased in 3,000 psi red concrete.

The second concrete duct bank is 30 feet long & contains one 3" Rigid Galvanized Steel Conduit encased in 3,000 psi red concrete.

The hours of operation on Geary Street are from 9:00 AM to 3:00 PM in accordance with specification section 01 55 26.53. para.3.01.A.2.

The scope of work was broken into meaningful activities shown below:

2. Detailed Scope:

		<u>Specification</u>	
		<u>Section</u>	
10	Traffic Control	01 55 26.53	Traffic Regulations (UMS)
20	Potholing	02 30 00	Subsurface Investigation
30	Pavement Demolition	02 41 00	Demolition
40	Install Duct Bank	26 05 43	Undreground Ducts and Raceways for Station Power
		31 23 33	Trenching and Backfilling
50	Place Concrete Base & Sidewalk	32 13 13.53	Concrete Paving (UMS)
			SFDPW Section 7 - Concrete Base
60	Place 2" Asphalt Concrete Wearing Surface (ACWS)	32 12 16	Asphalt Paving
			SFDPW Section 212 - Asphalt Concrete Wearing Surface

2. Labor Rates:

Labor rates used in the estimate are based on following latest Northern California prevailing wage determinations issued on August 22, 2013.

Wage Determinations:

NC-23-102-13-2013-3	Traffic Control/Lane Closure Laborer
NC-23-102-1-2013-2	Laborer & Related Classifications
NC-23-63-1-2013-2	Operating Engineer (Heavy & Highway Work)
NC-23-261-1-2013-1	Teamsters
Local Union 6	Electricians

3. Equipment Rates:

Equipment rates used in the estimate are based on Caltrans Equipment Rental Rates effective April 1, 2013.

4. Material Rates:

Material rates are based on quotes.

6. Subcontractor Rates:

Subcontractor rates are based on quotes.

PROPOSED CONTRACT CHANGE

FINDING OF FACTS

Contract No. 1300 Stations, Surface, Track and Systems Date July 23, 2014
 PCC No. _____
 PCC Title Relocation of Traffic Signal Controller Cabinet at Geary and Stockton Streets
 PCC Initiator W. Seng Dept. SFMTA

<p>Description of PCC: Relocate the traffic signal controller cabinet at the northeast corner of Geary and Stockton Streets to northwest corner of Geary and Stockton.</p> <p>Scope of work includes, but is not limited to, the following addition activities:</p> <ul style="list-style-type: none"> • Installation of additional PVC and GRS conduits and wires • Installation of a 30 foot long duct bank containing two (2) 2" PVC SCH 80 conduits and one (1) 3" PVC SCH 80 conduit • Installation of a 30 foot long duct bank containing one (1) 3" rigid galvanized steel conduit
<p>Reason/Need for PCC: Relocation of cabinet is required to comply with requirement for DPW Surface Mounted Facilities Permit.</p>
<p>Location/Station: UMS</p>
<p>Configuration Control Analysis: None (Design Control)</p>
<p>Recommended Action: Relocate the traffic signal controller cabinet as shown.</p>
<p>Estimate: \$22,808</p>
<p>Spec. Ref.: 01 55 26.53 Traffic Regulations (UMS) 02 30 00 Subsurface Investigation 02 41 00 Demolition 26 05 45 Raceway and Pullboxes for Outdoor Electrical Work 31 23 33 Trenching and Backfilling 32 12 16 Asphalt Paving 34 41 13 Traffic Signals</p>
<p>Drawing Nos.: None</p>
<p>Attachments: Sketch WS20130520, Mark-up dwg UMS1253 ET-103, rev 0.</p>

Recommended by: _____ Date _____
 Rich Redmond, Program Manager/Construction (SFMTA Representative)

Concur in Principle: JWang Date 7/22/14
 Jane Wang, Program Manager/Project Development (SFMTA Representative)

PROPOSED CONTRACT CHANGE

Contract No. 1300 Stations, Surface, Track and Systems Date 7/23/14
 PCC No. 13
 PCC Title Relocation of Traffic Signal Controller Cabinet at Geary and Stockton Streets

Description of PCC:	
<u>Summary of Changes:</u> Relocate one (1) traffic signal controller cabinet and one (1) pull box. Scope of work includes, but is not limited to, the following addition activities:	
<ul style="list-style-type: none"> • Installation of additional PVC and GRS conduits and wires • Installation of a 30 foot long duct bank containing two (2) 2" PVC SCH 80 conduits and one (1) 3" PVC SCH 80 conduit • Installation of a 30 foot long duct bank containing one (1) 3" rigid galvanized steel conduit 	
<u>Supplementary Conditions</u>	
<ul style="list-style-type: none"> • If required; otherwise N/A 	
Spec Ref.	01 55 26.53 Traffic Regulations (UMS) 02 30 00 Subsurface Investigation 02 41 00 Demolition 26 05 45 Raceway and Pullboxes for Outdoor Electrical Work 31 23 33 Trenching and Backfilling 32 12 16 Asphalt Paving 34 41 13 Traffic Signals
Drawing Nos.	None
Attachments	Sketch WS20130520, Mark-up dwg UMS1253 ET-103, rev 0.
The Contractor shall submit a cost proposal and time extension proposal in accordance with General Provisions Section 6.02 B and Section 7.02 B.	

Recommended by: _____ Date _____
 Rich Redmond, Program Manager/Construction (SFMTA Representative)

Concur in Principle:  _____ Date 7/23/14
 Ben Volberding, Project Contract Administrator (SFMTA Representative)



**FRONTIER-KEMPER
CONSTRUCTORS, INC.**

A Tutor Perini Company

CHINATOWN STATION

Overall SEM Sequence

- a) Excavate Headhouse to EL49
- b) Composite Wall - Pour 1 (EL49)
- c) Install Strut Level 3 (EL52.5)

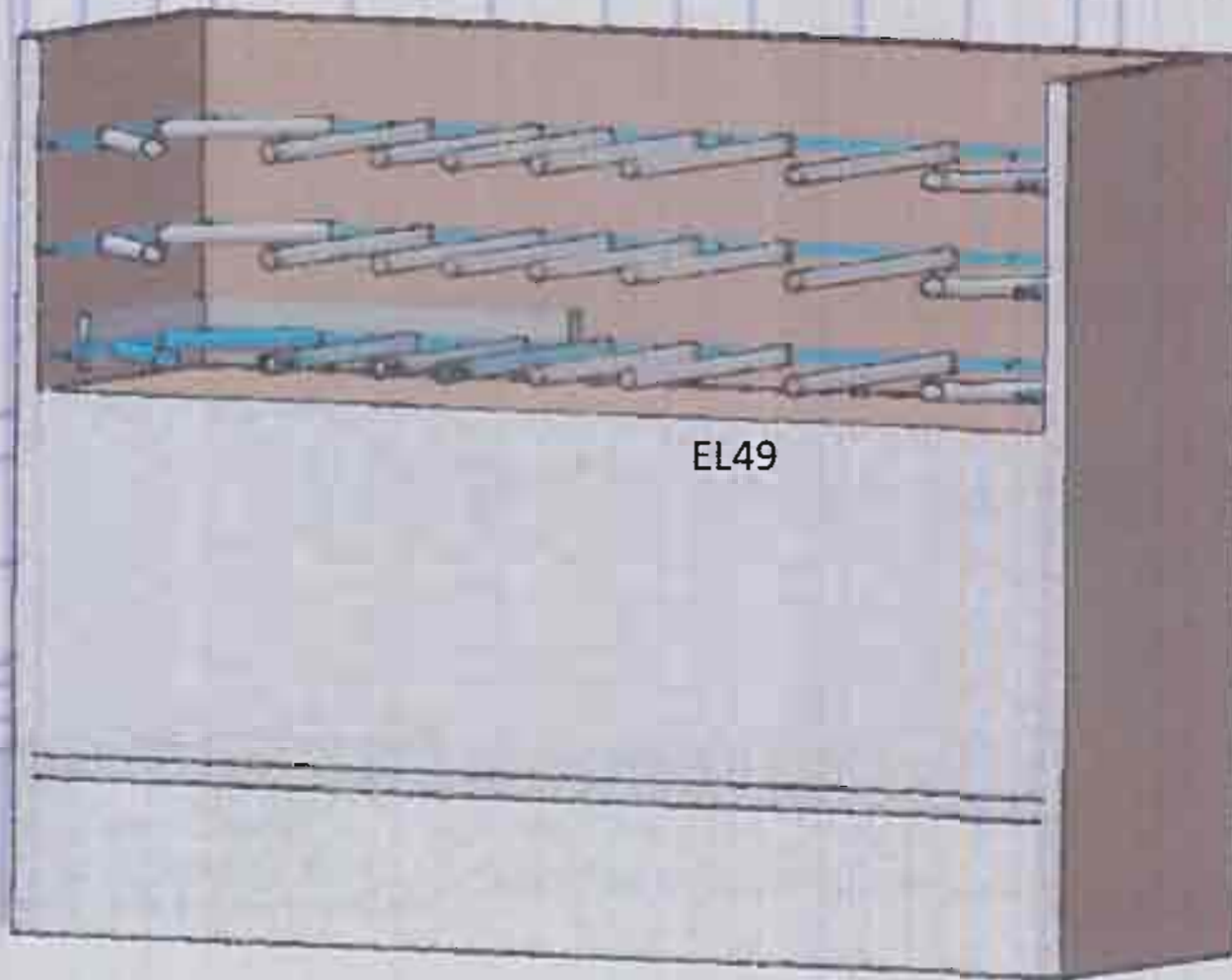

- a) Excavate Headhouse to EL35
- b) Composite Wall - Pour 2 (EL36)
- c) Cross Cut Barrel Vaults – Install Phase 1 (Sides)
- d) Cross Cut Drill Exploratory Holes

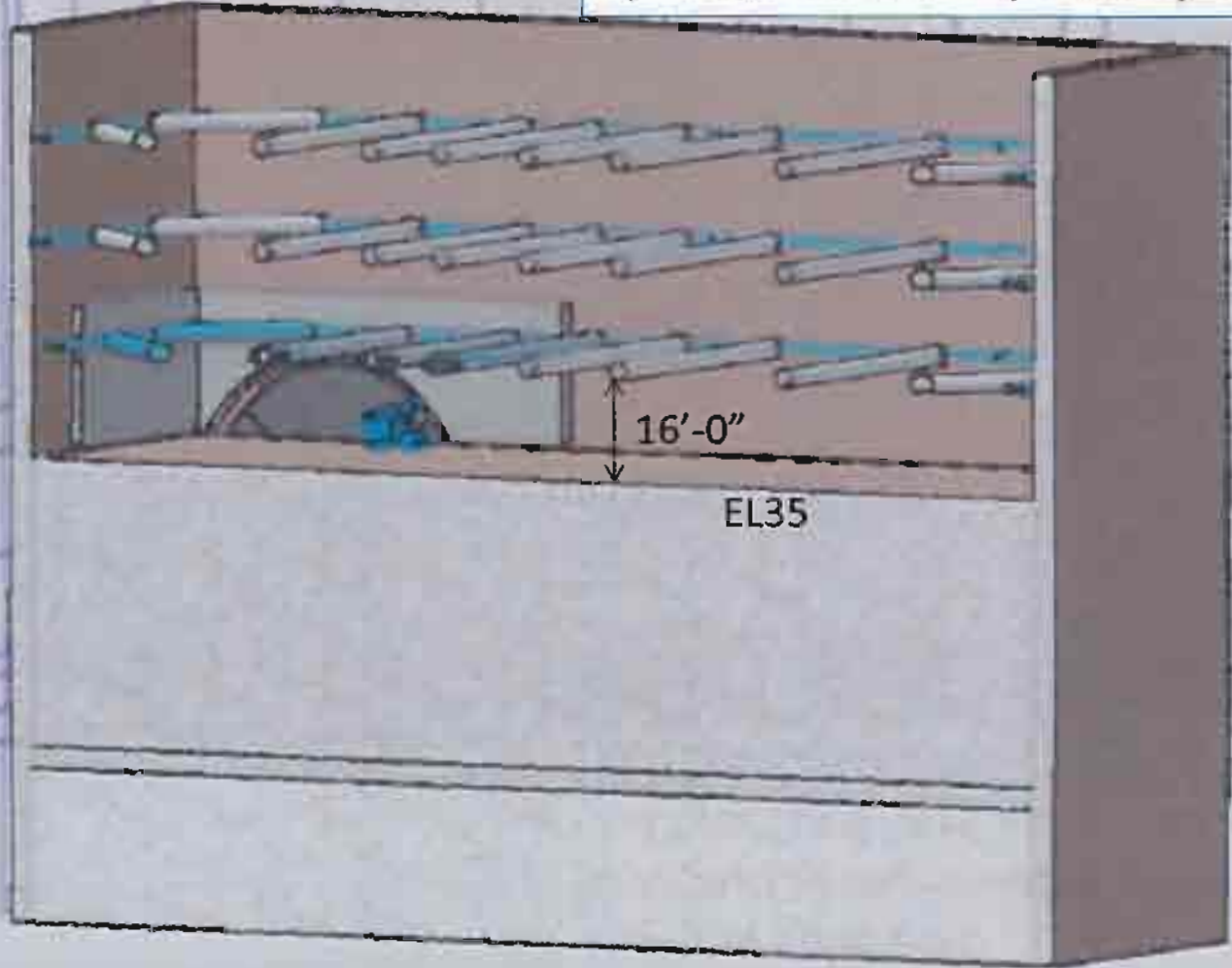

- a) Ramp up to EL40
- b) Cross Cut Barrel Vaults – Install Phase 2 (Crown)
- c) Cross Cut Drill Exploratory Holes

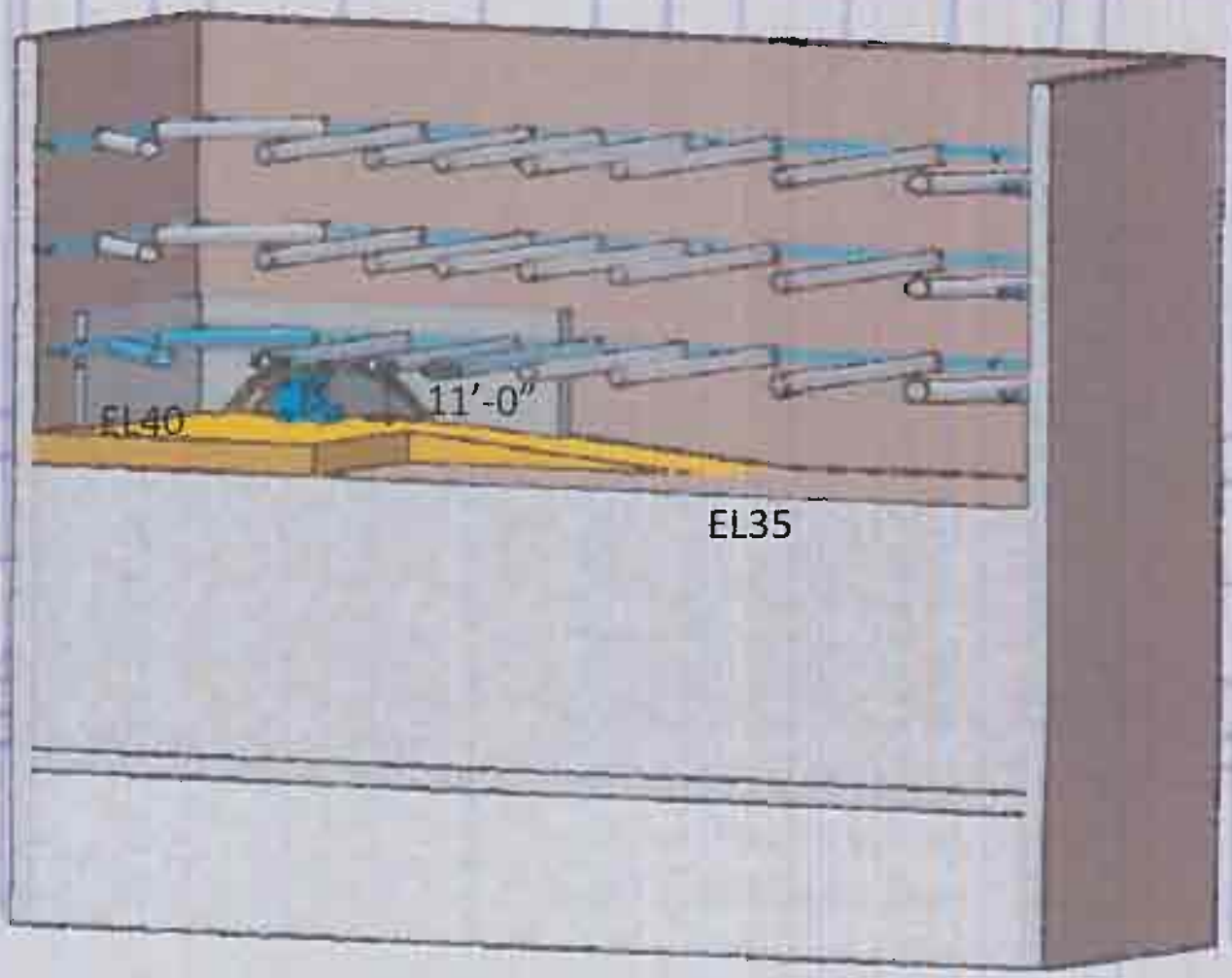

- a) Ramp down to EL27
- b) Cross Cut Barrel Vaults – Install Phase 3 (Lowest)
- c) Cross Cut Drill Exploratory Holes

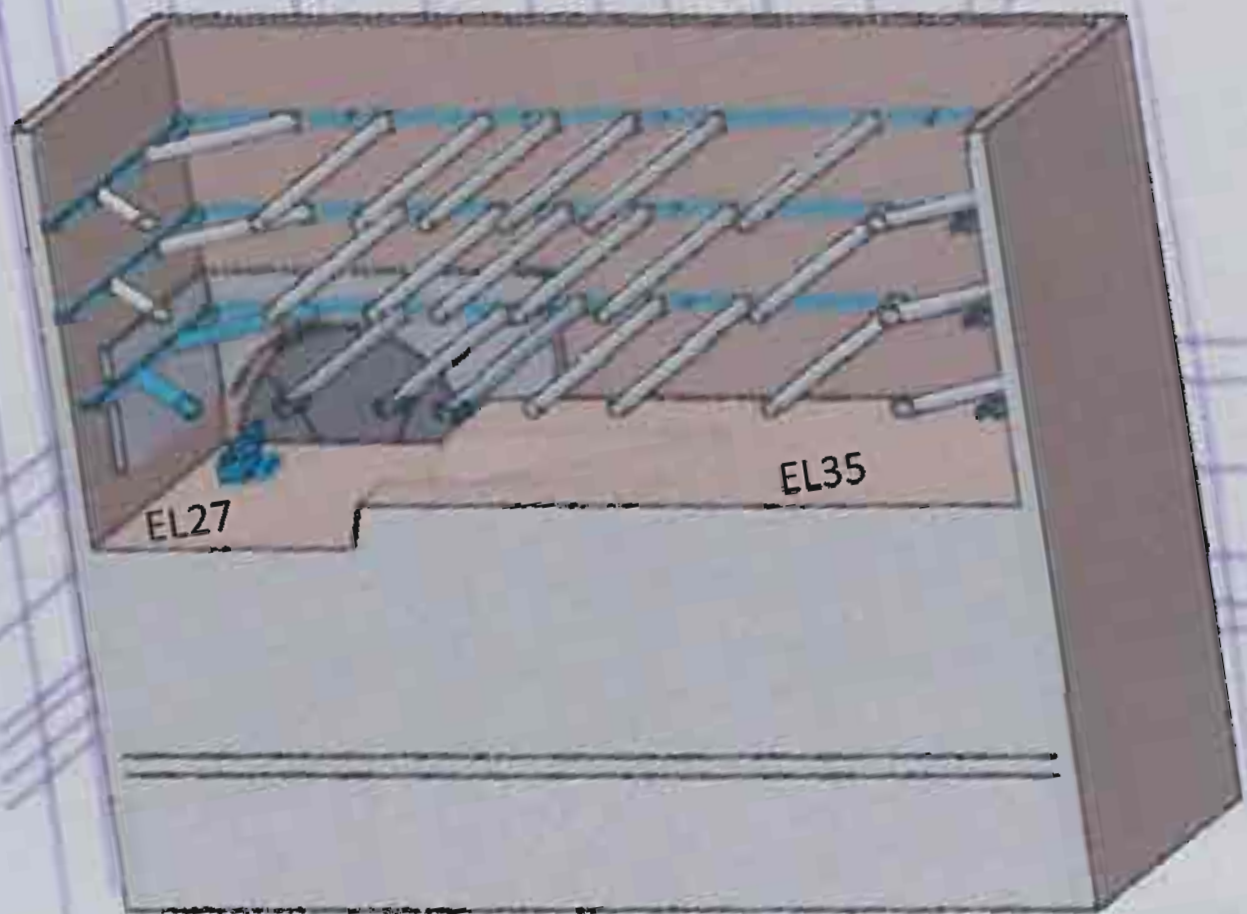

a) Install Strut Level 4 (EL 36)

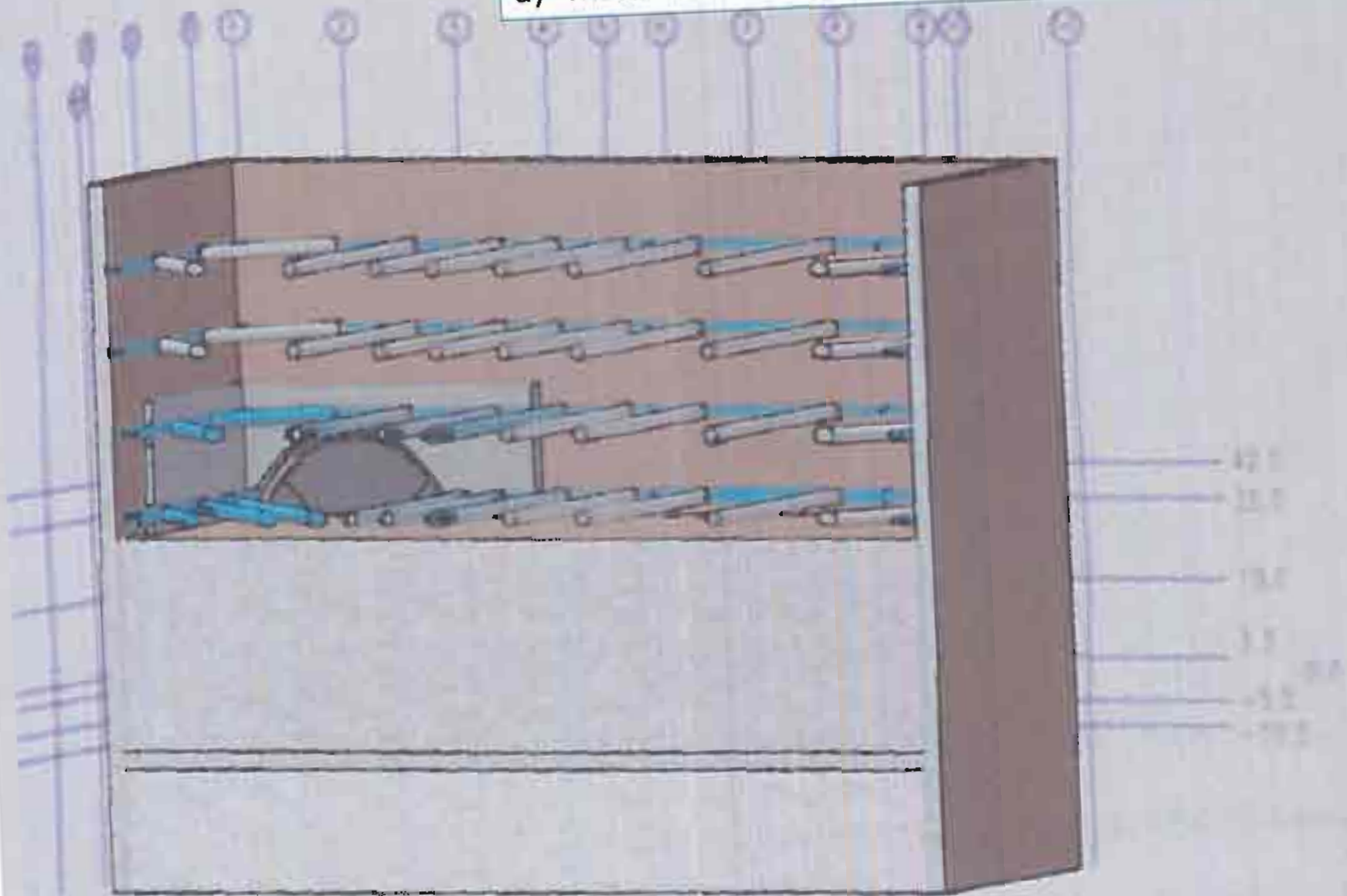

- a) Cut Grade to EL17
- b) Composite Wall - Pour 3 (EL26)

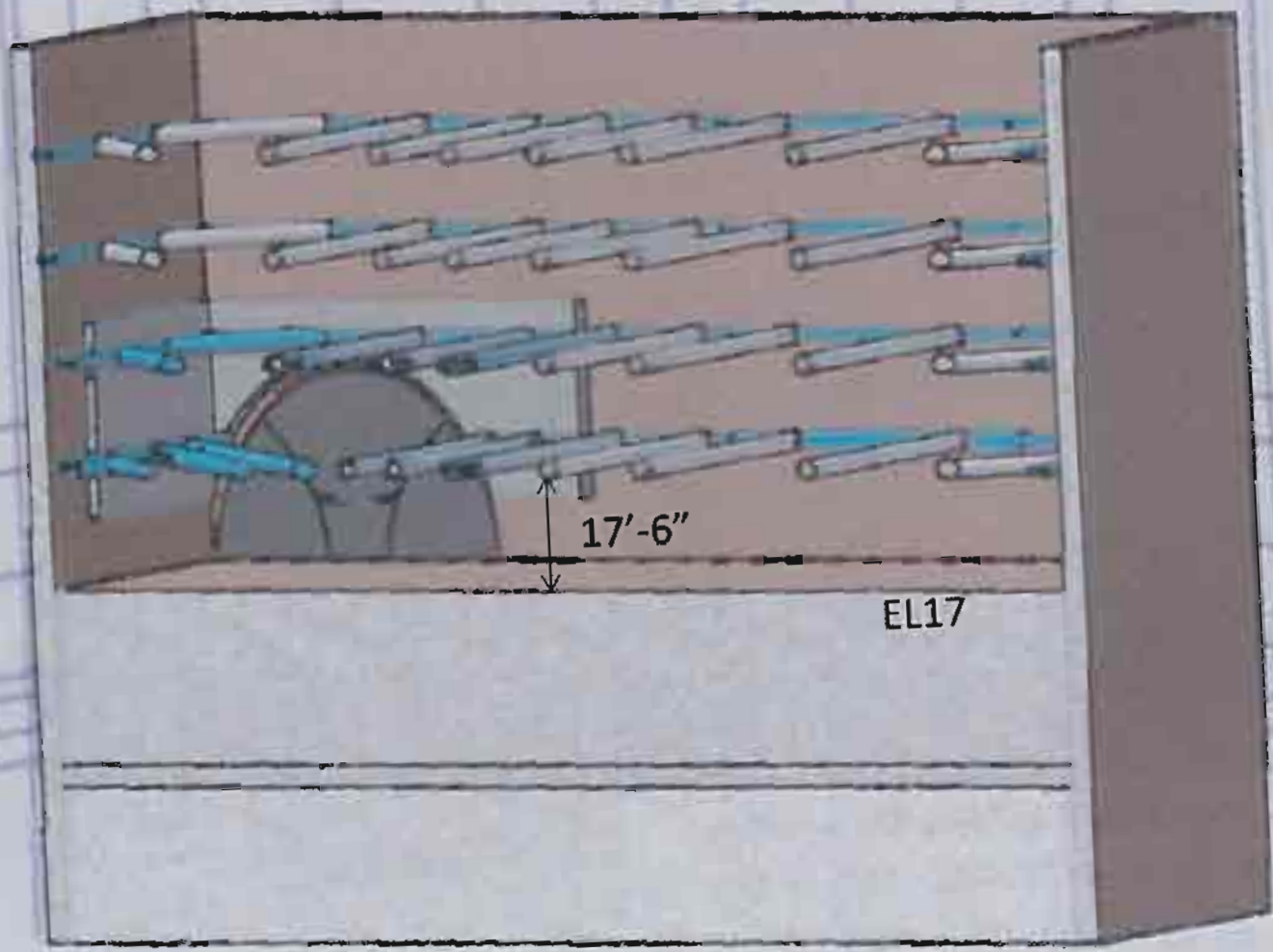

- a) Ramp down at face to EL12
- b) Cross Cut - Breakout & Excavate Top Heading
Side Drifts Left & Right

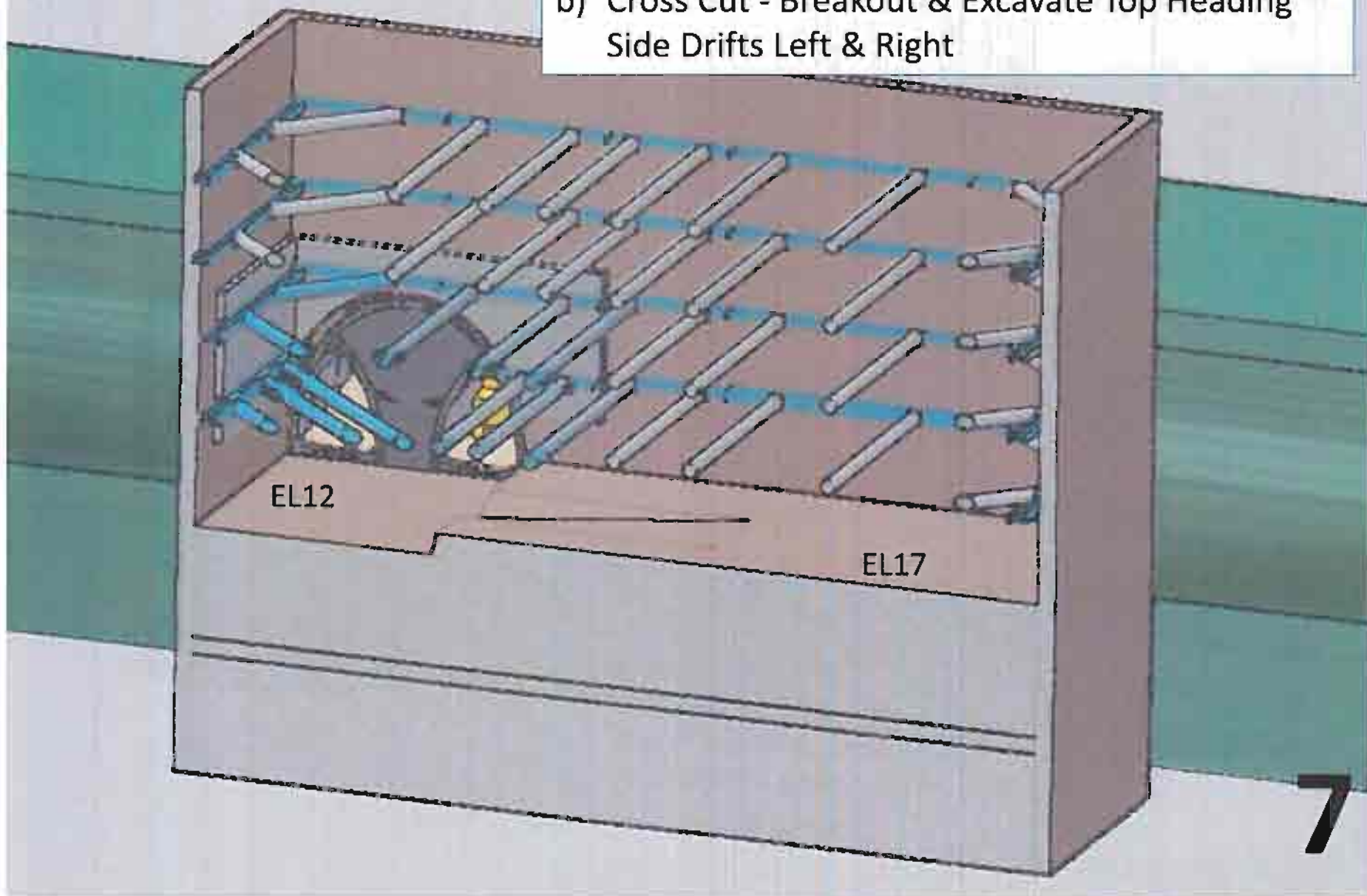

- a) Ramp up to EL26 in front of face
- b) Cross Cut - Breakout & Excavate Top Heading Center Drift

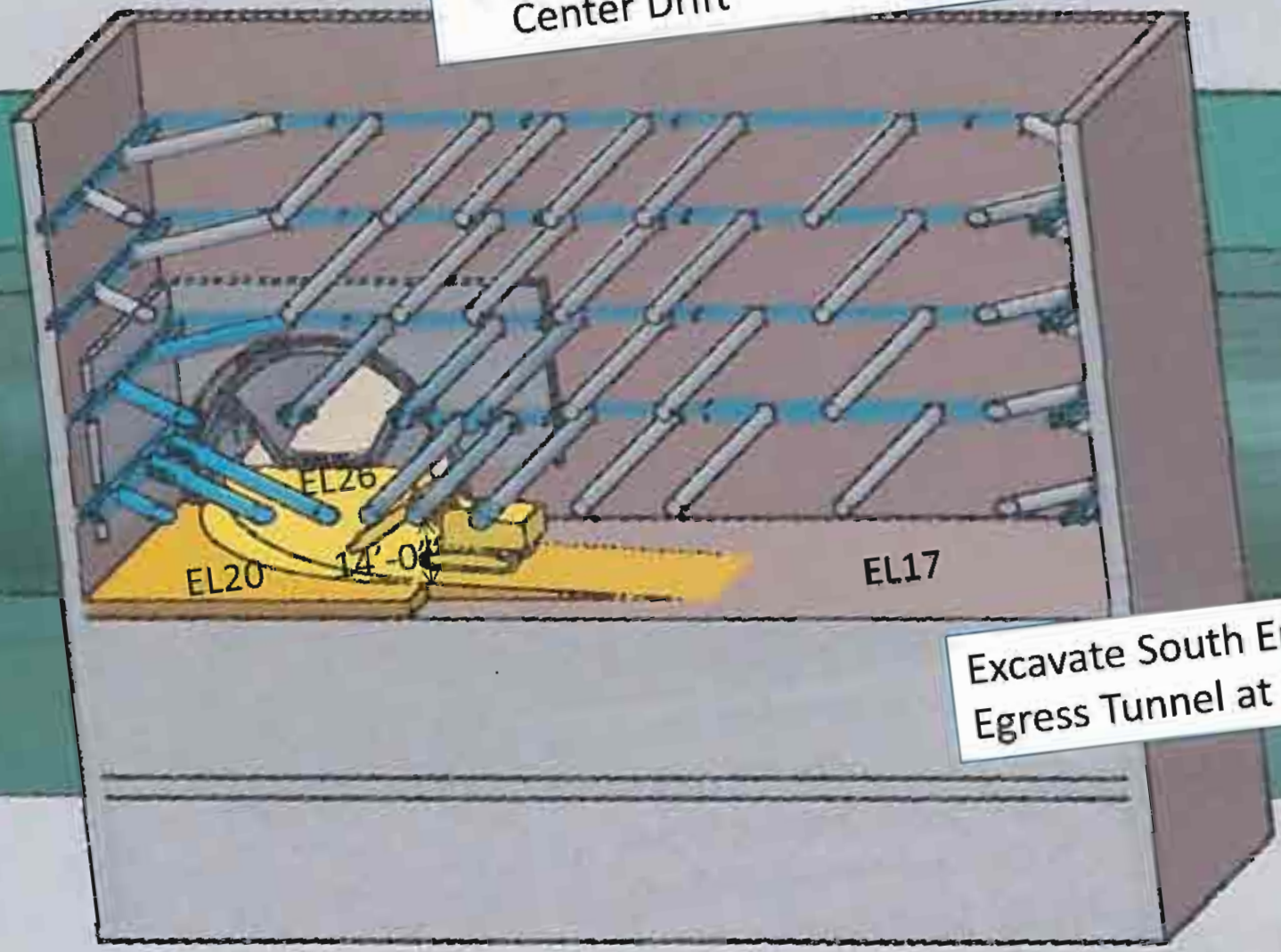

Excavate South Emergency Egress Tunnel at this time

- a) Install Strut Level 5 (EL20)
- b) Cut grade down to EL3.5
- c) Install Strut Level 6 (11.5) & 7 (-3.5) diagonals in NW corner
- d) Slope down to EL-5 in front of Cross Cut

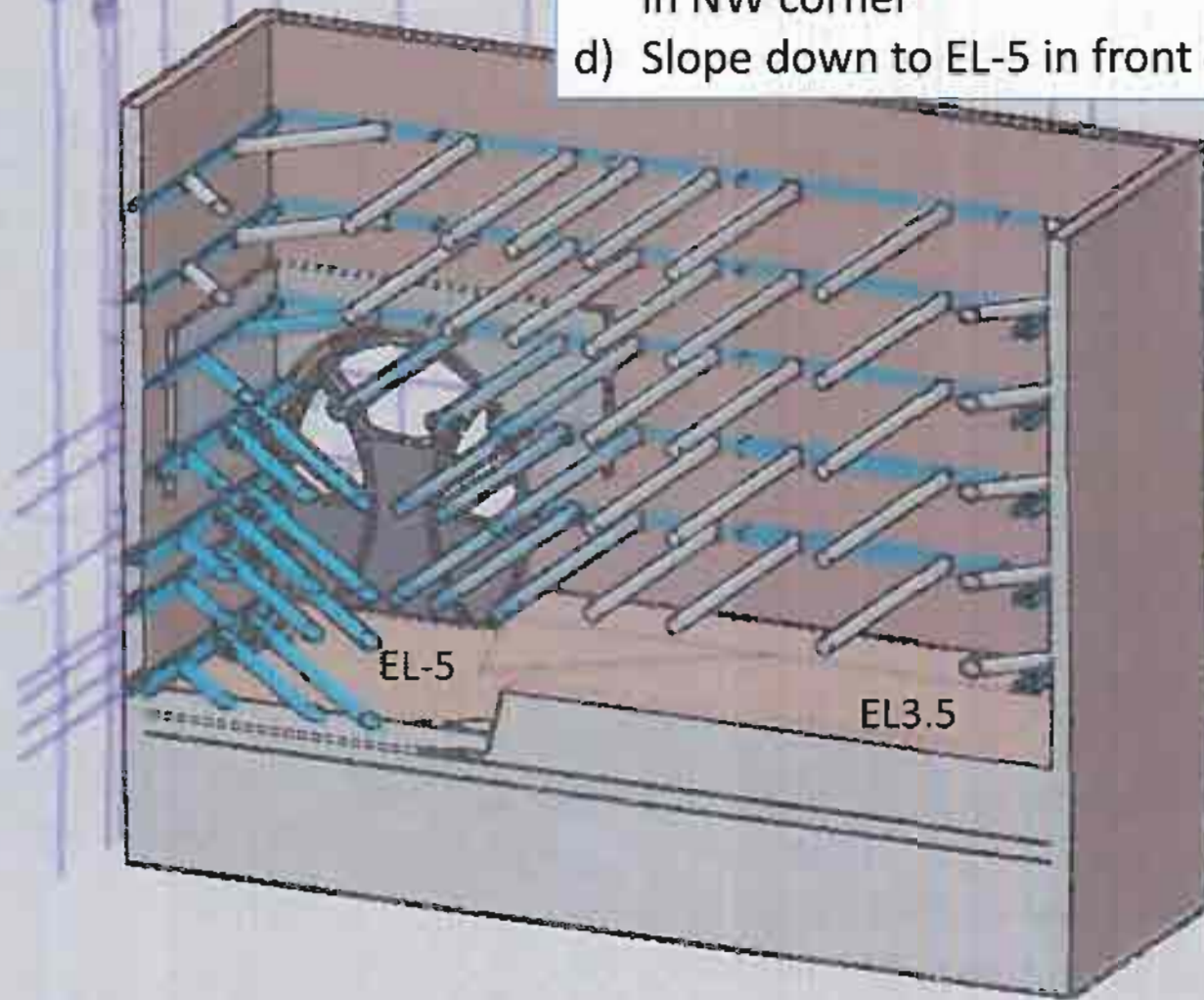

a) Cross Cut – Breakout Bench/Invert of the Side Drifts Left & Right

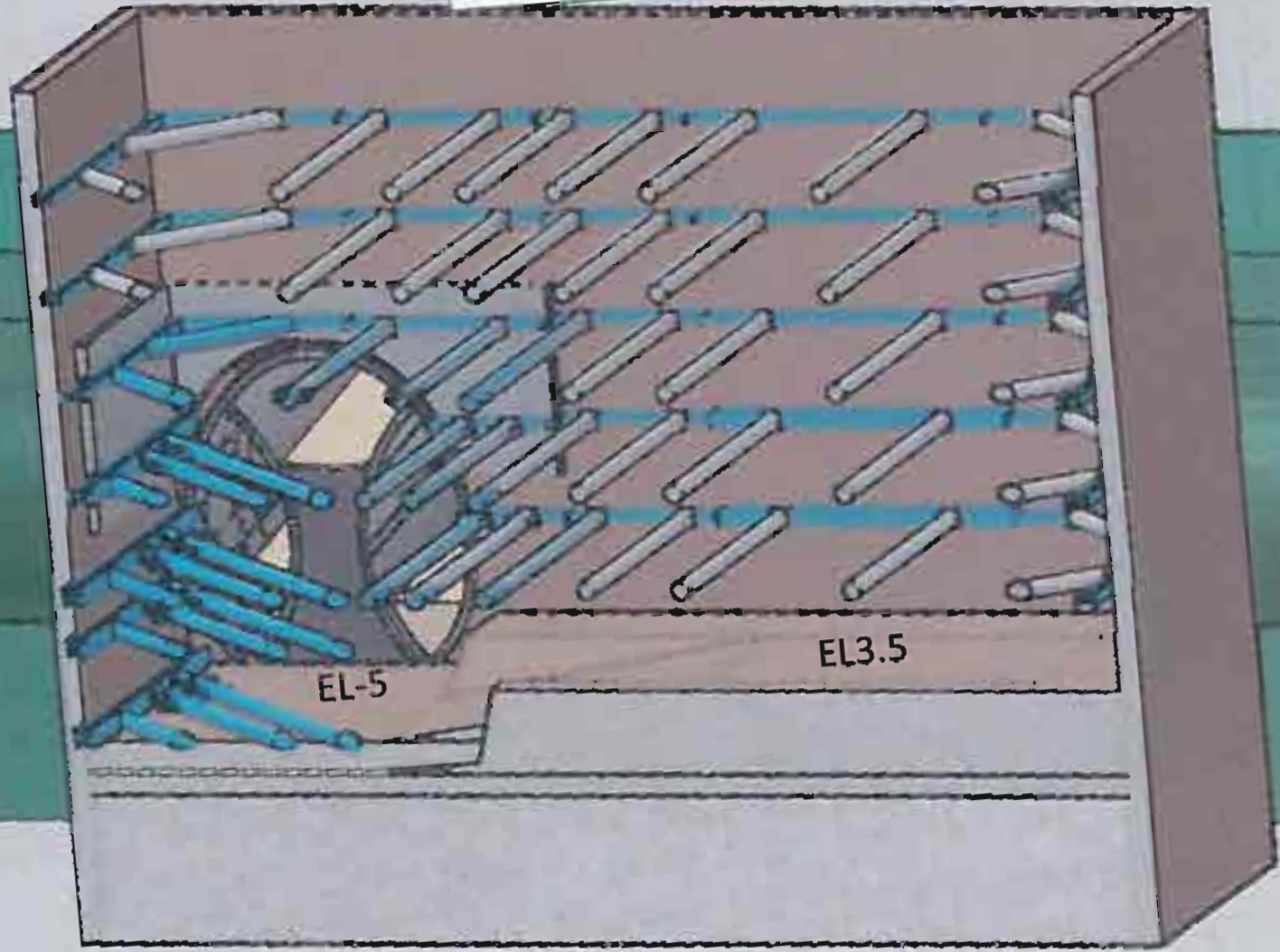

- a) Fill ramp up to EL0 (running surface)
- b) Cross Cut – Excavate Bench/Invert of the Side Drifts Left & Right

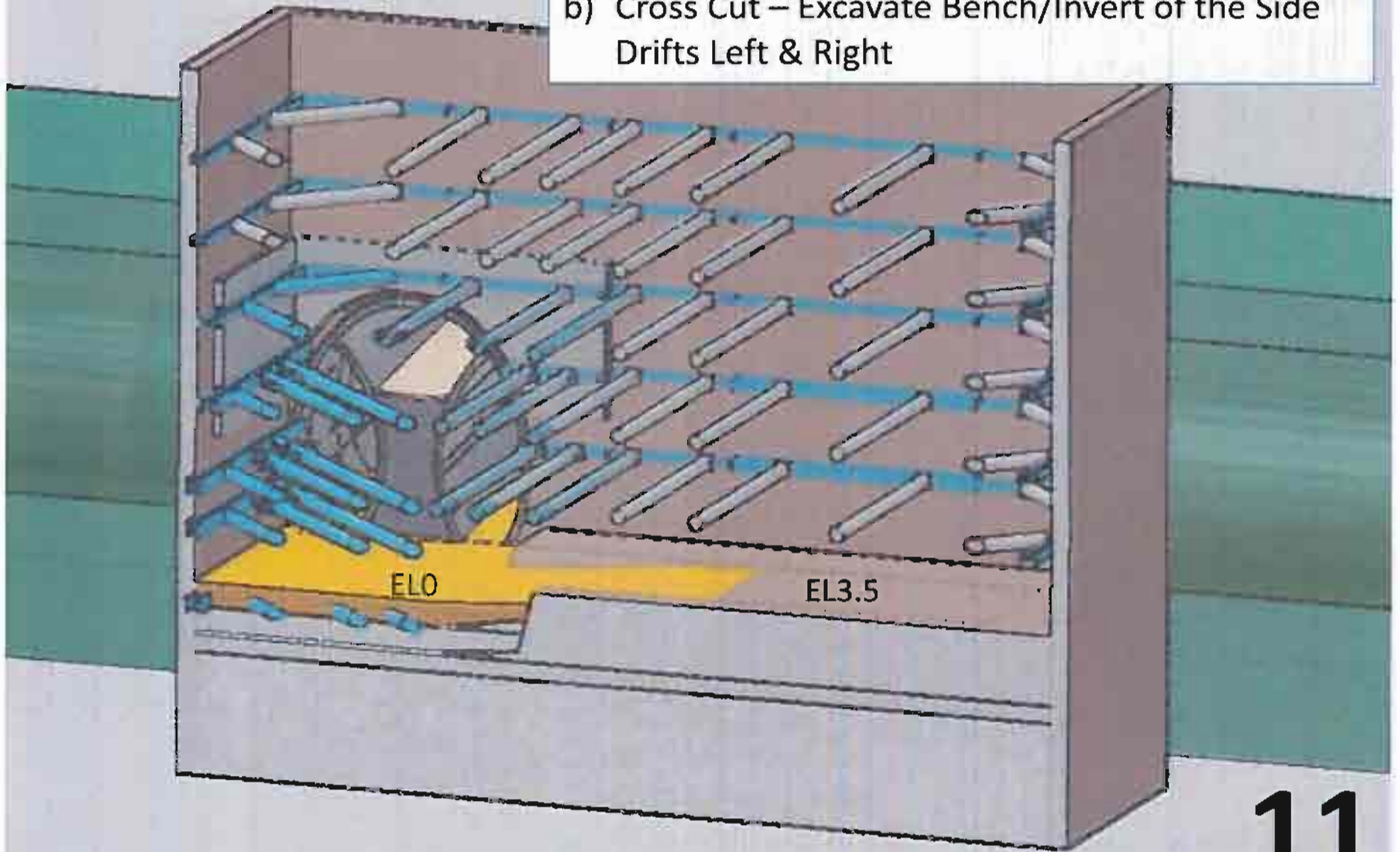

- a) Fill to EL6.5 and build ramped curve to EL12 in front of Cross Cut
- b) Cross Cut – Breakout & Excavate Middle Bench of Center Drift

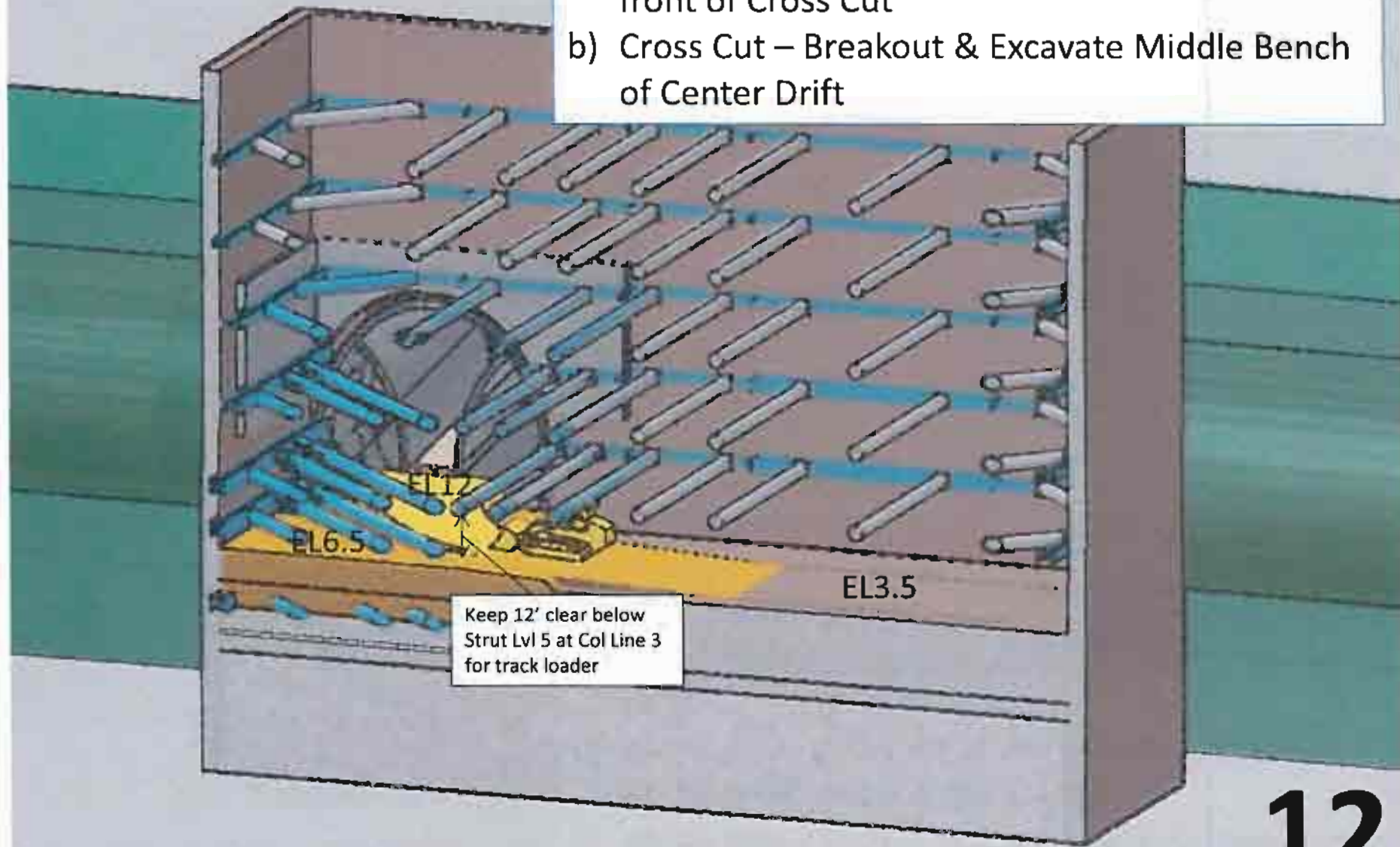

Keep 12' clear below
Strut Lvl 5 at Col Line 3
for track loader

- a) Ramp down to EL-5 at Col Line3, then down to EL-10 using local curved ramp.
- b) Cross Cut – Breakout Bench/Invert of Center Drift

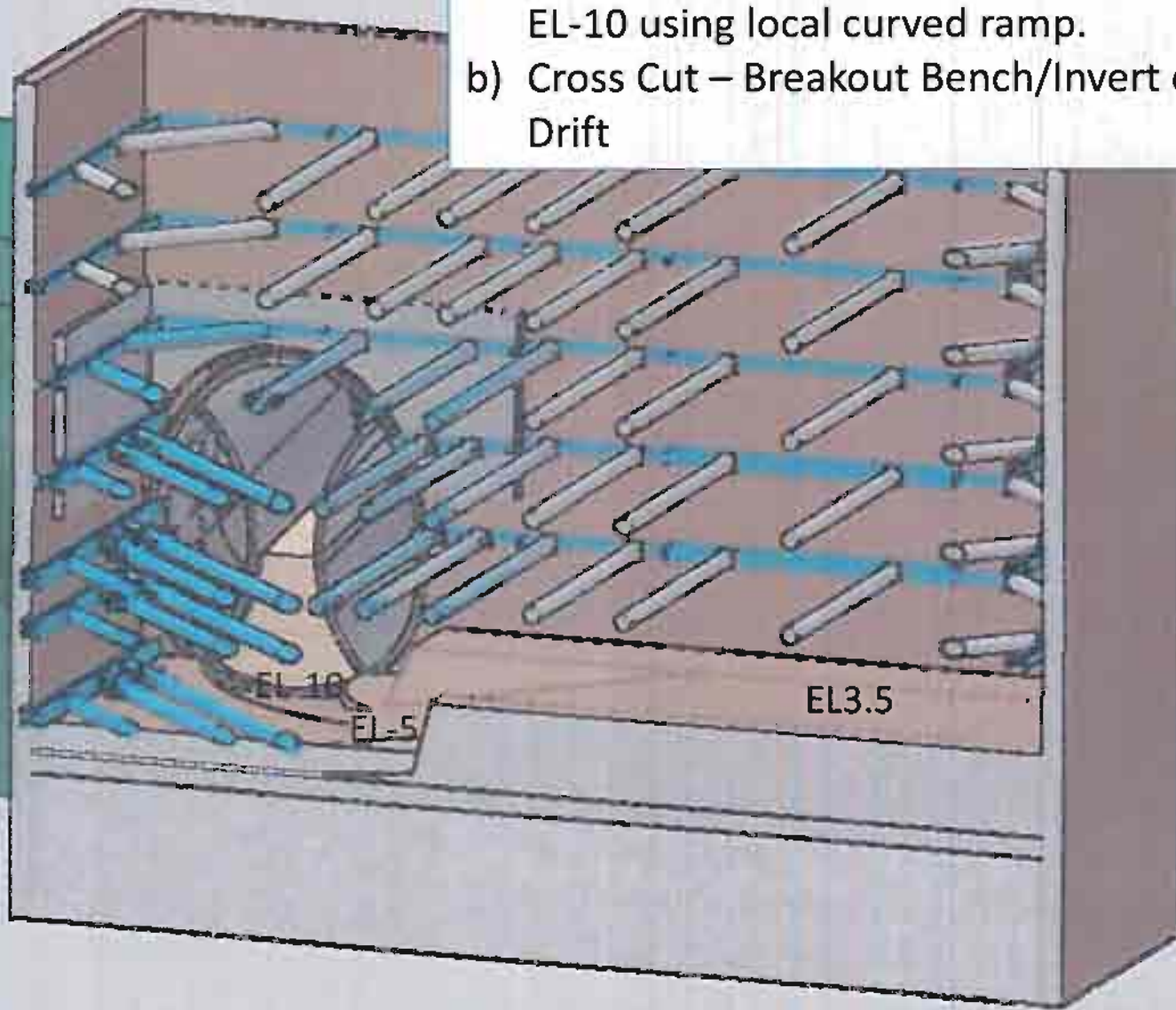

- a) Fill curved ramp up to EL-5 (running surface)
- b) Cross Cut – Excavate Bench/Invert of Center Drift

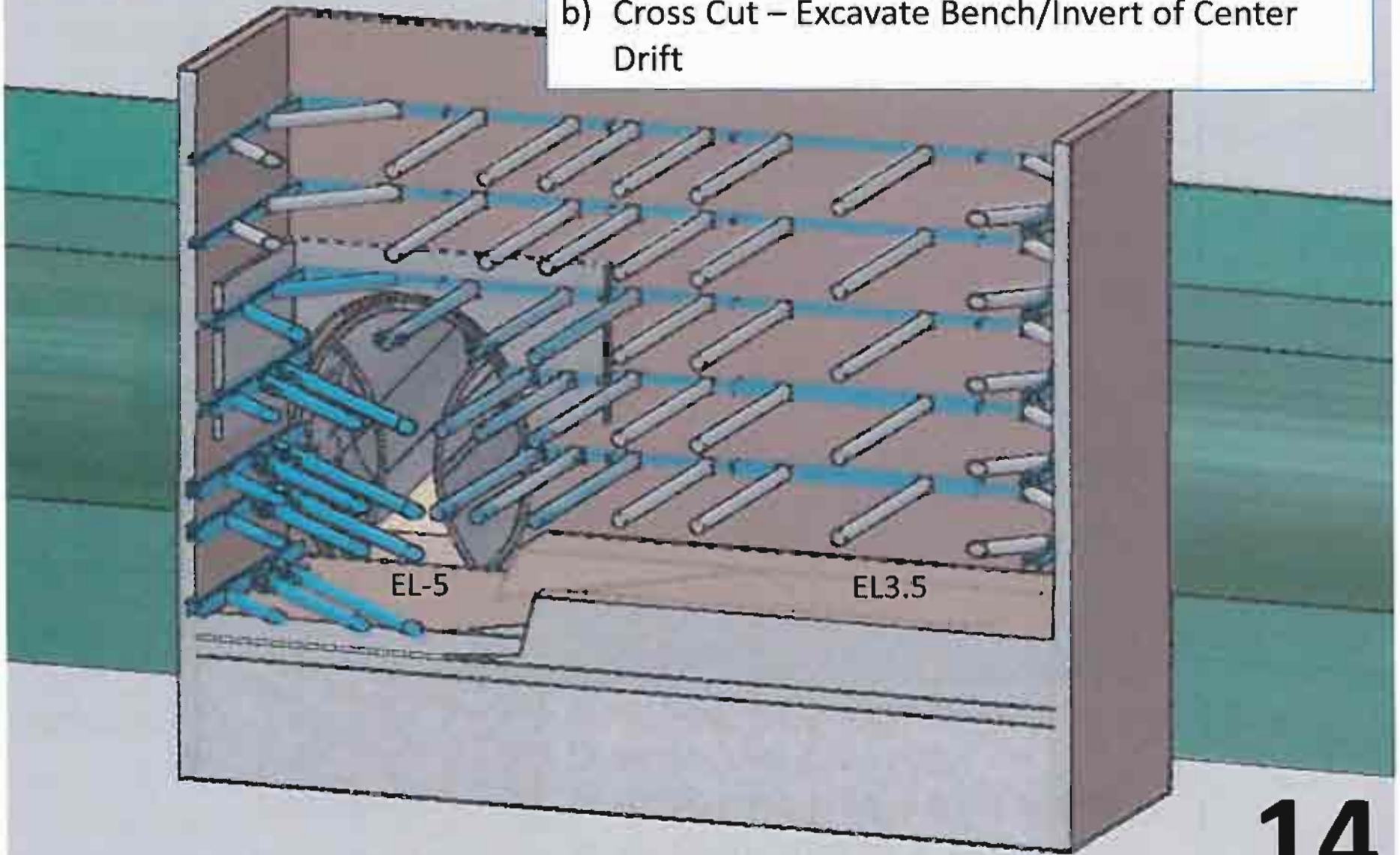

- a) Fill Headhouse up to EL22
- b) Ramp up to EL26 in front of face
- c) Fill in Cross Cut to EL26
- d) Demolish Sidewalls inside Cross Cut to EL26

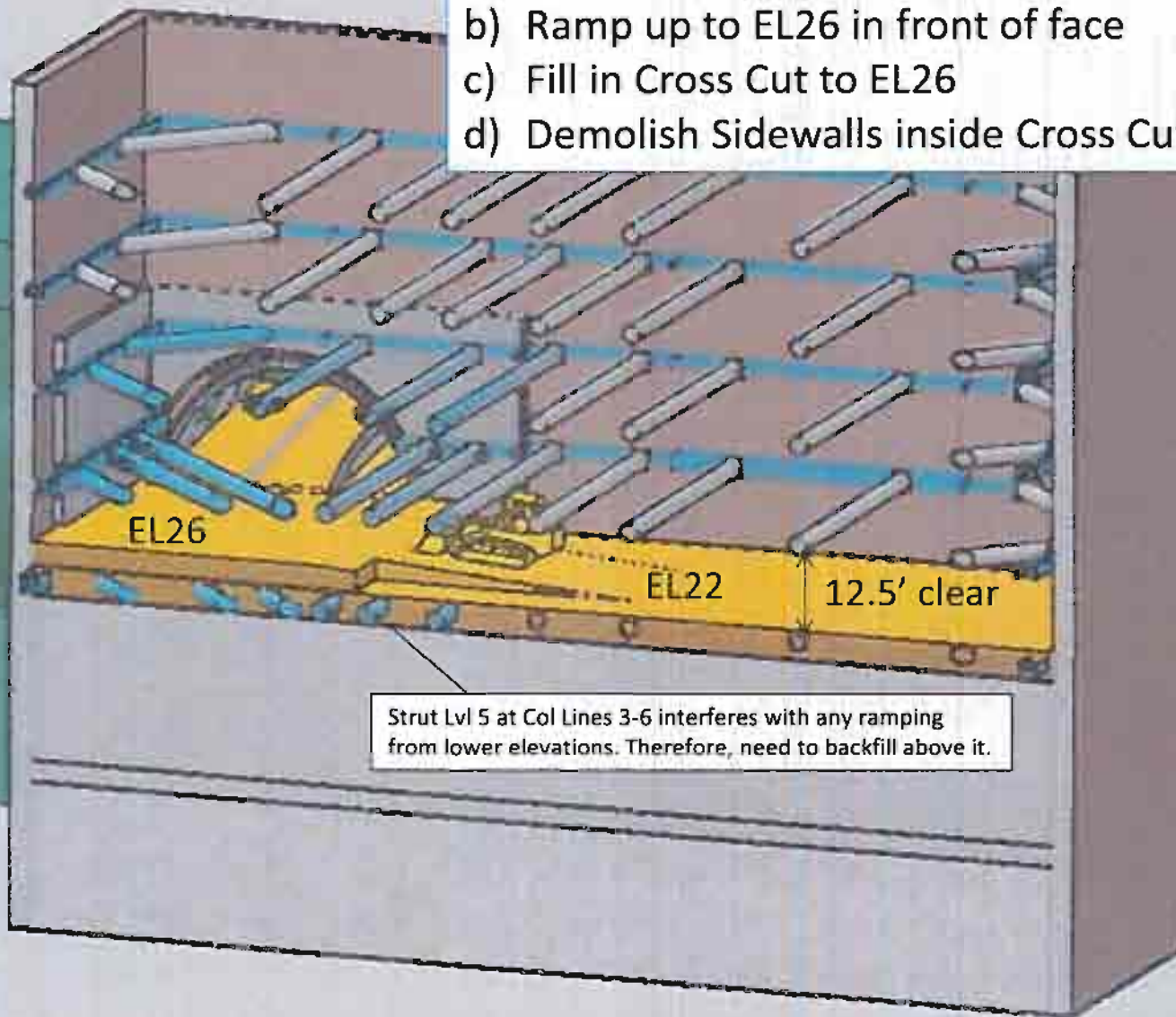

a) Install Barrel Vaults for Platform South and Platform North

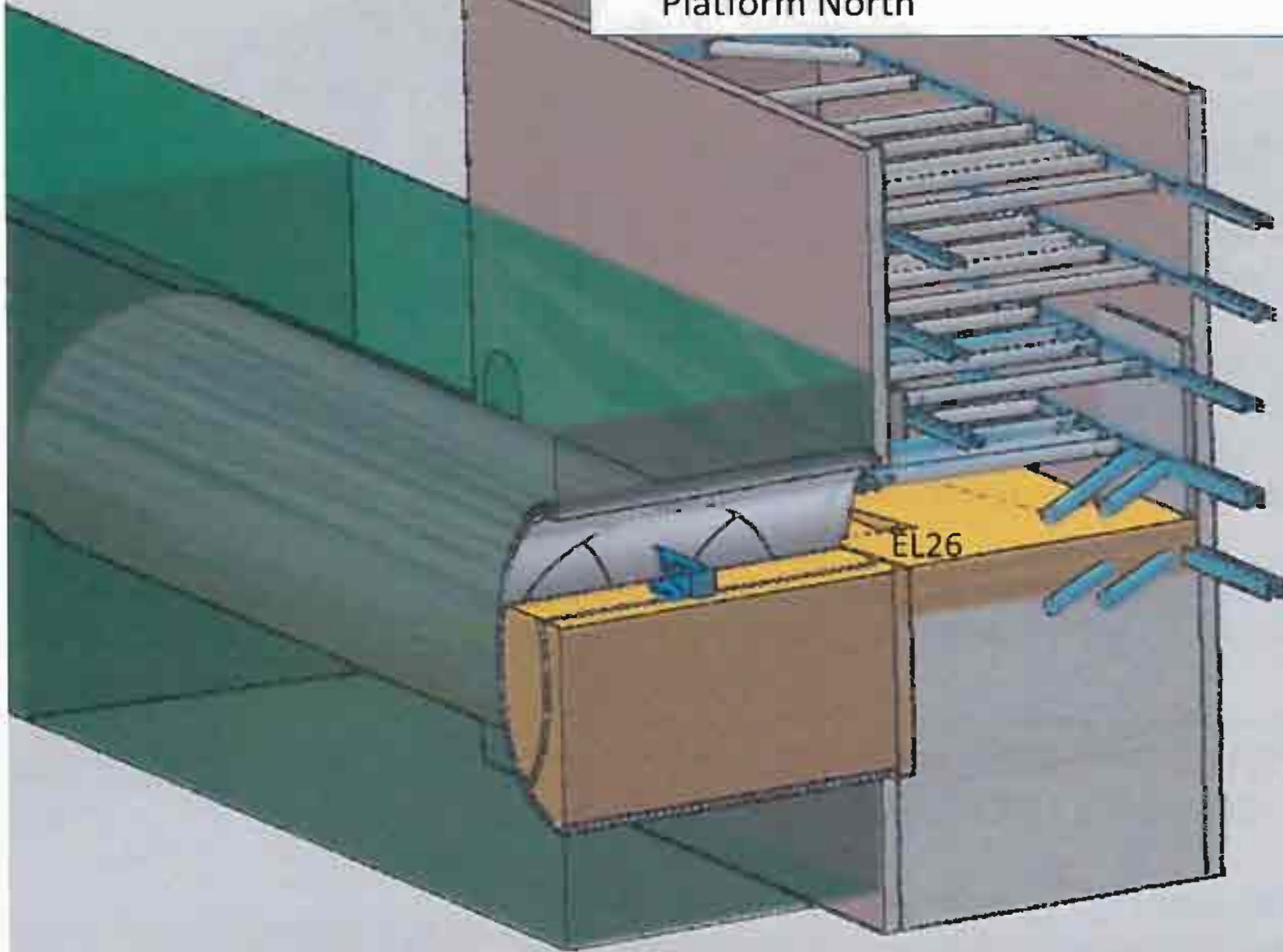

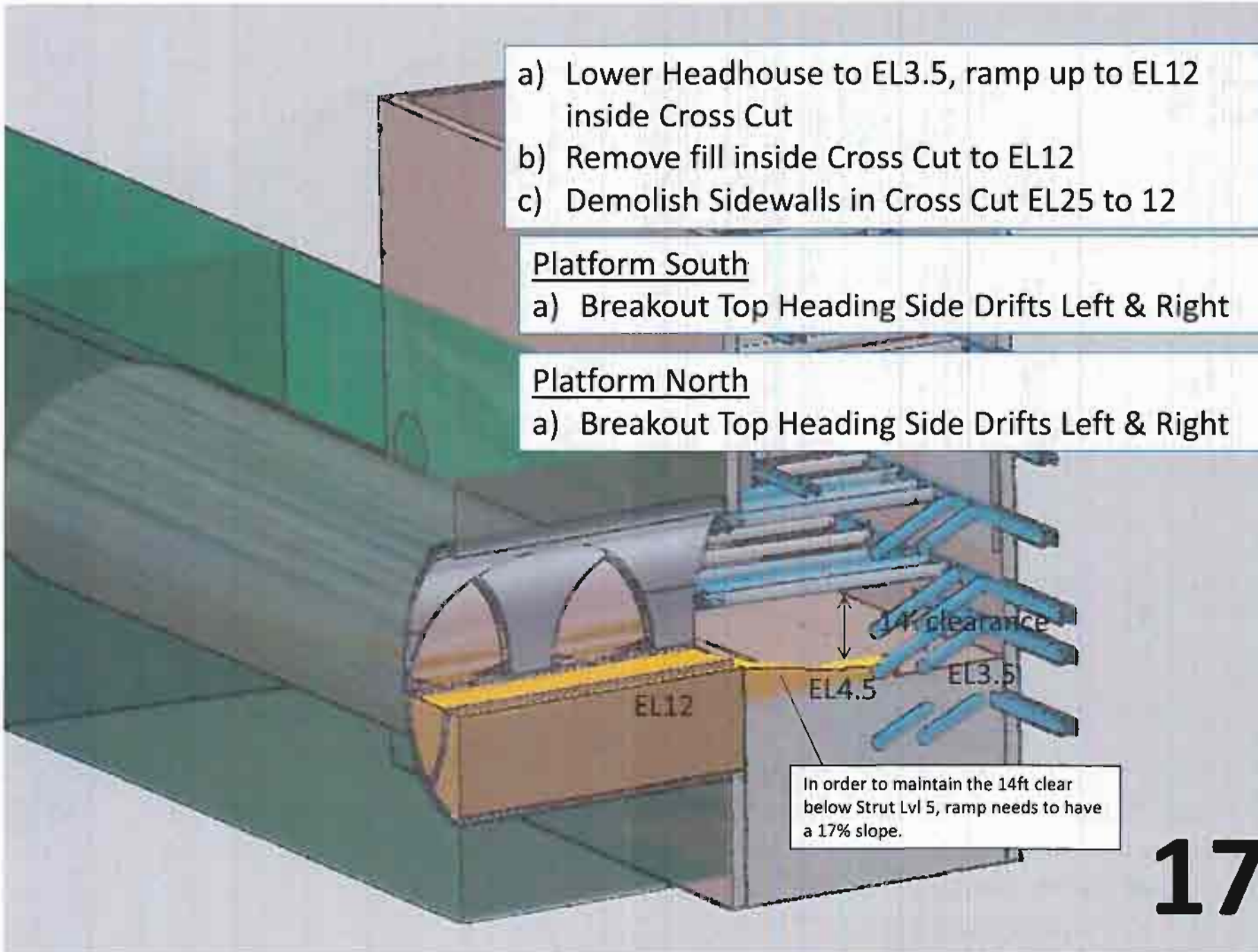
- 
- a) Lower Headhouse to EL3.5, ramp up to EL12 inside Cross Cut
 - b) Remove fill inside Cross Cut to EL12
 - c) Demolish Sidewalls in Cross Cut EL25 to 12

Platform South

- a) Breakout Top Heading Side Drifts Left & Right

Platform North

- a) Breakout Top Heading Side Drifts Left & Right

In order to maintain the 14ft clear below Strut Lvl 5, ramp needs to have a 17% slope.

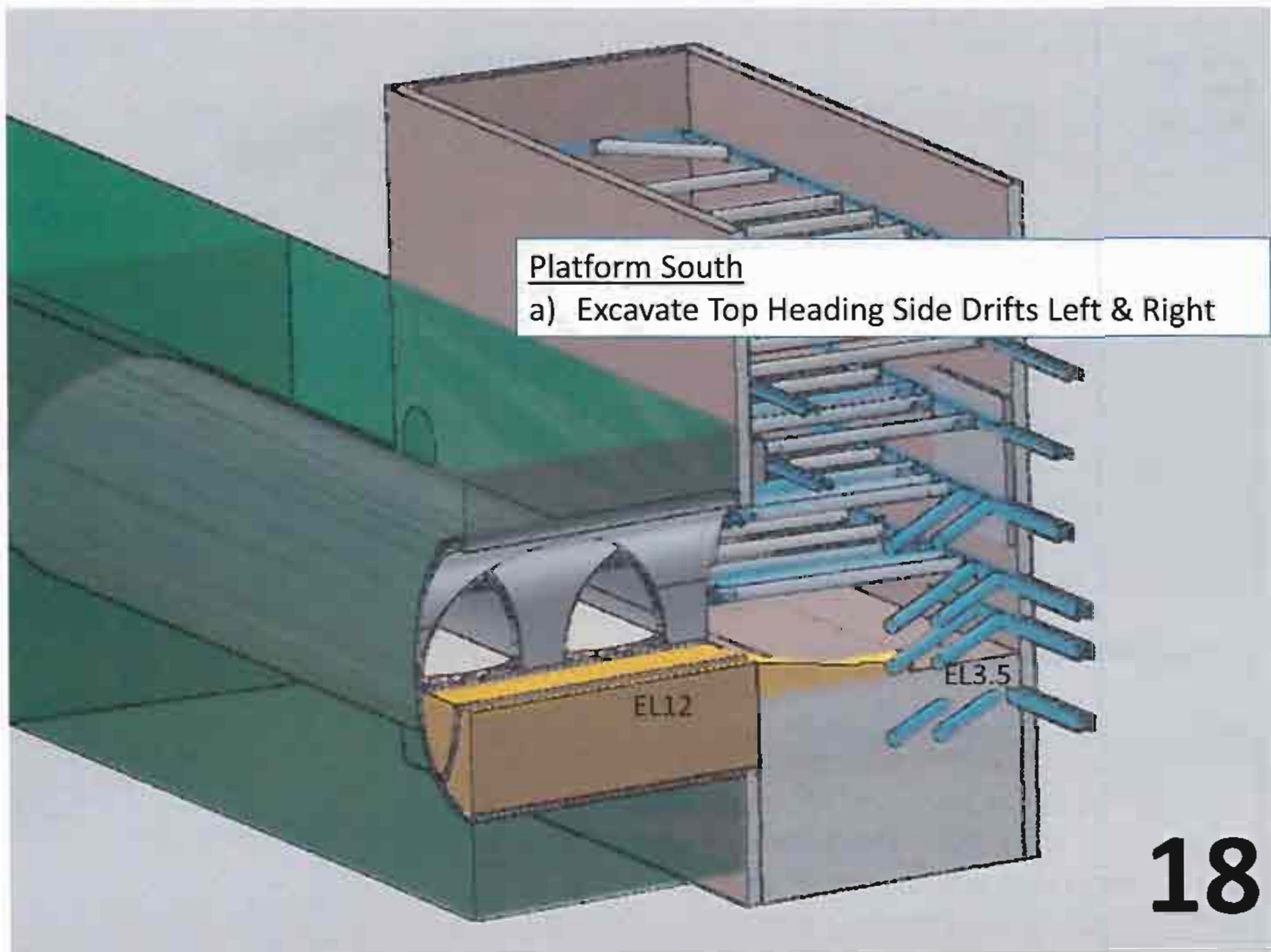

Platform South
a) Excavate Top Heading Side Drifts Left & Right

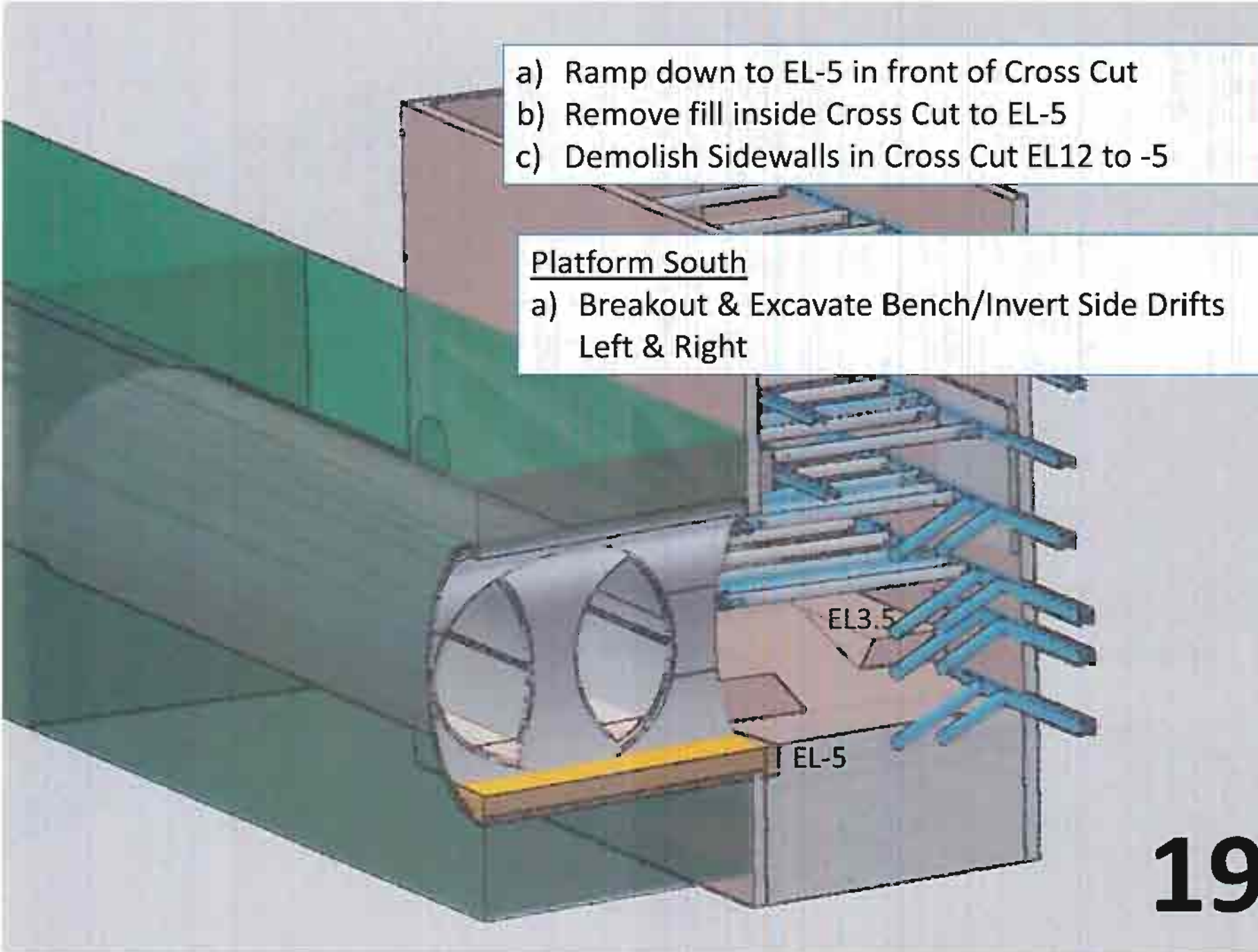
- 
- The diagram shows a 3D cutaway view of a tunnel construction site. On the left, a large green structure represents the tunnel's exterior. A yellow ramp leads down to a cross cut. Inside the cross cut, there are blue structural elements representing side drifts. A yellow horizontal bar is labeled 'EL-5'. A blue structural element is labeled 'EL3.5'. The background shows a brown structure representing the tunnel's interior.
- a) Ramp down to EL-5 in front of Cross Cut
 - b) Remove fill inside Cross Cut to EL-5
 - c) Demolish Sidewalls in Cross Cut EL12 to -5

Platform South

- a) Breakout & Excavate Bench/Invert Side Drifts Left & Right

- a) Fill Headhouse back up to EL22
- b) Fill inside Cross Cut to EL22

Platform South

- a) Breakout & Excavate Top Heading Center Drift

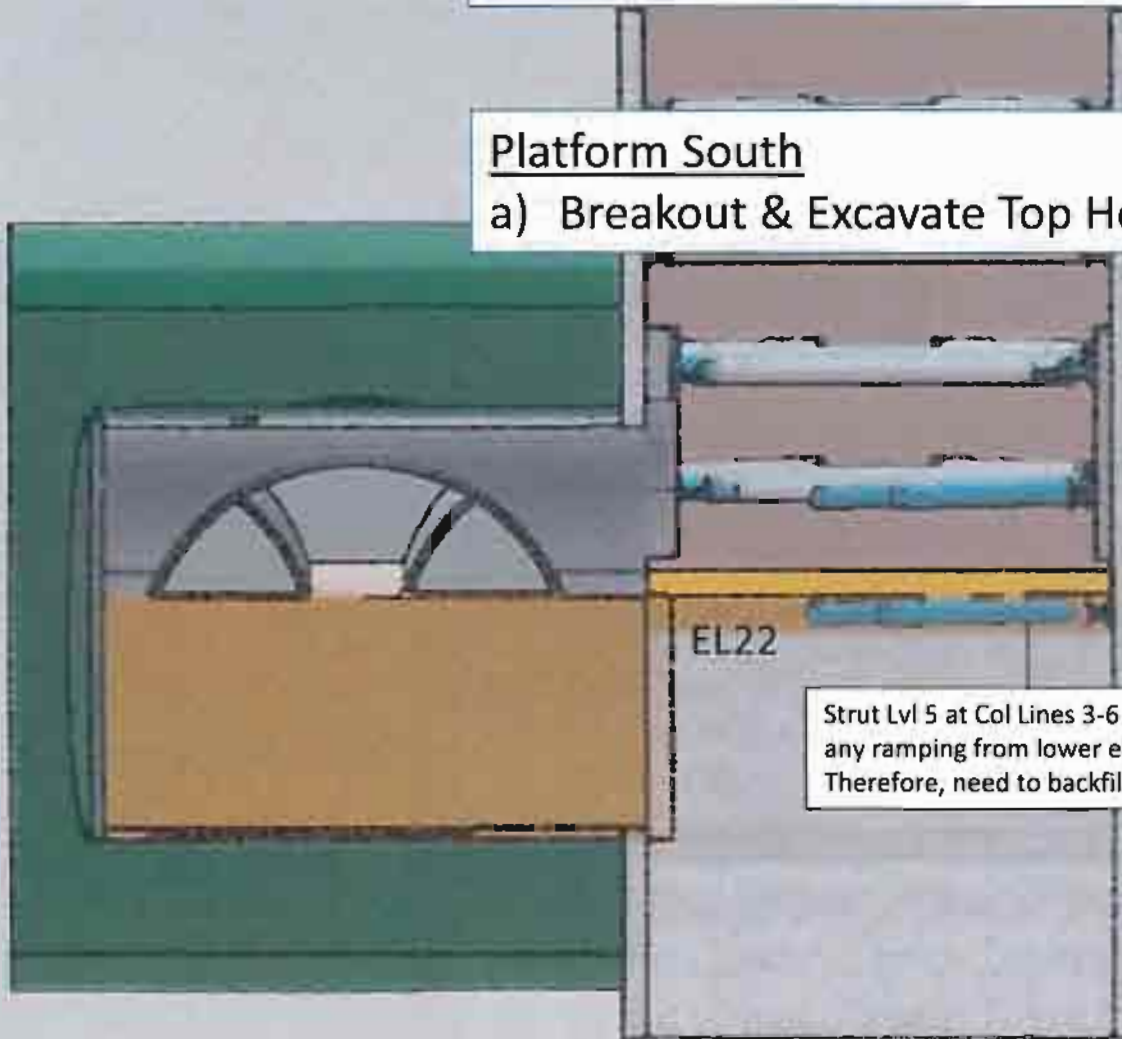

- a) Lower Headhouse to EL3.5
- b) Remove fill inside Cross Cut EL-5
- c) Slope down to EL-5 in front of Cross Cut

Platform South

- a) Breakout & Excavate Bench/Invert Center Drift

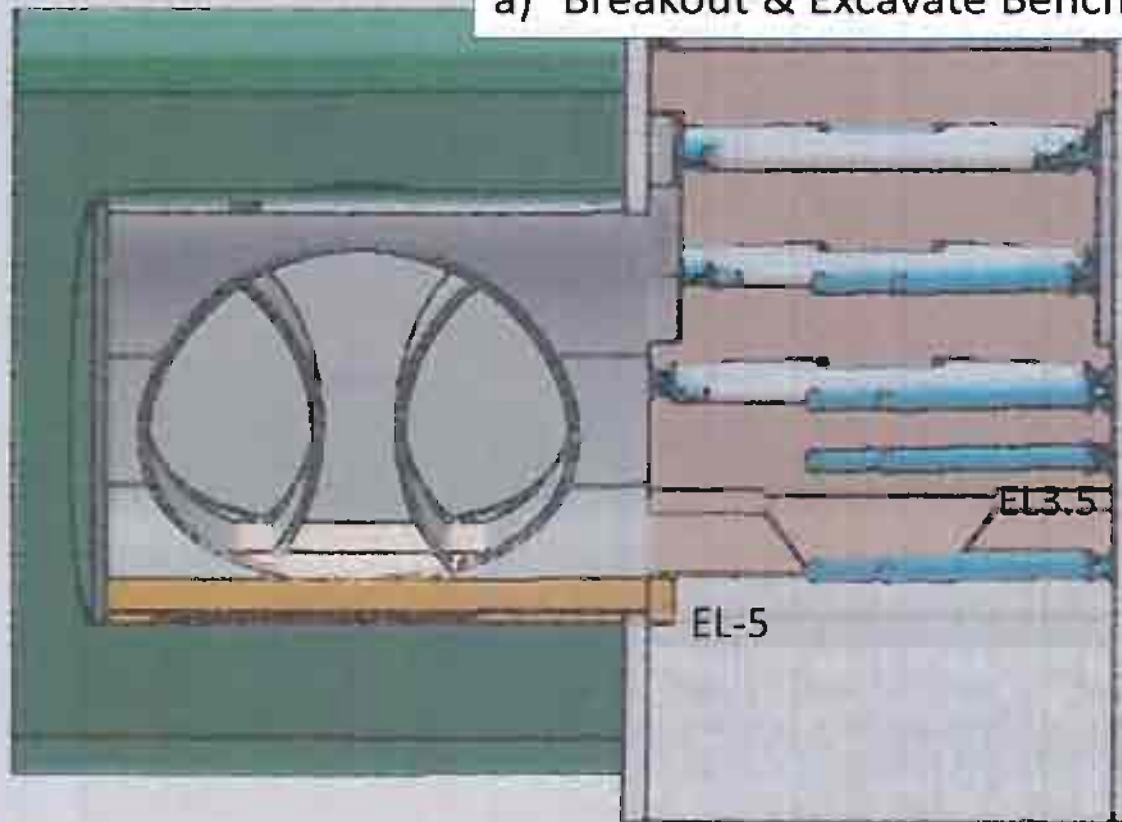

Platform South

a) Demolish Sidewalls

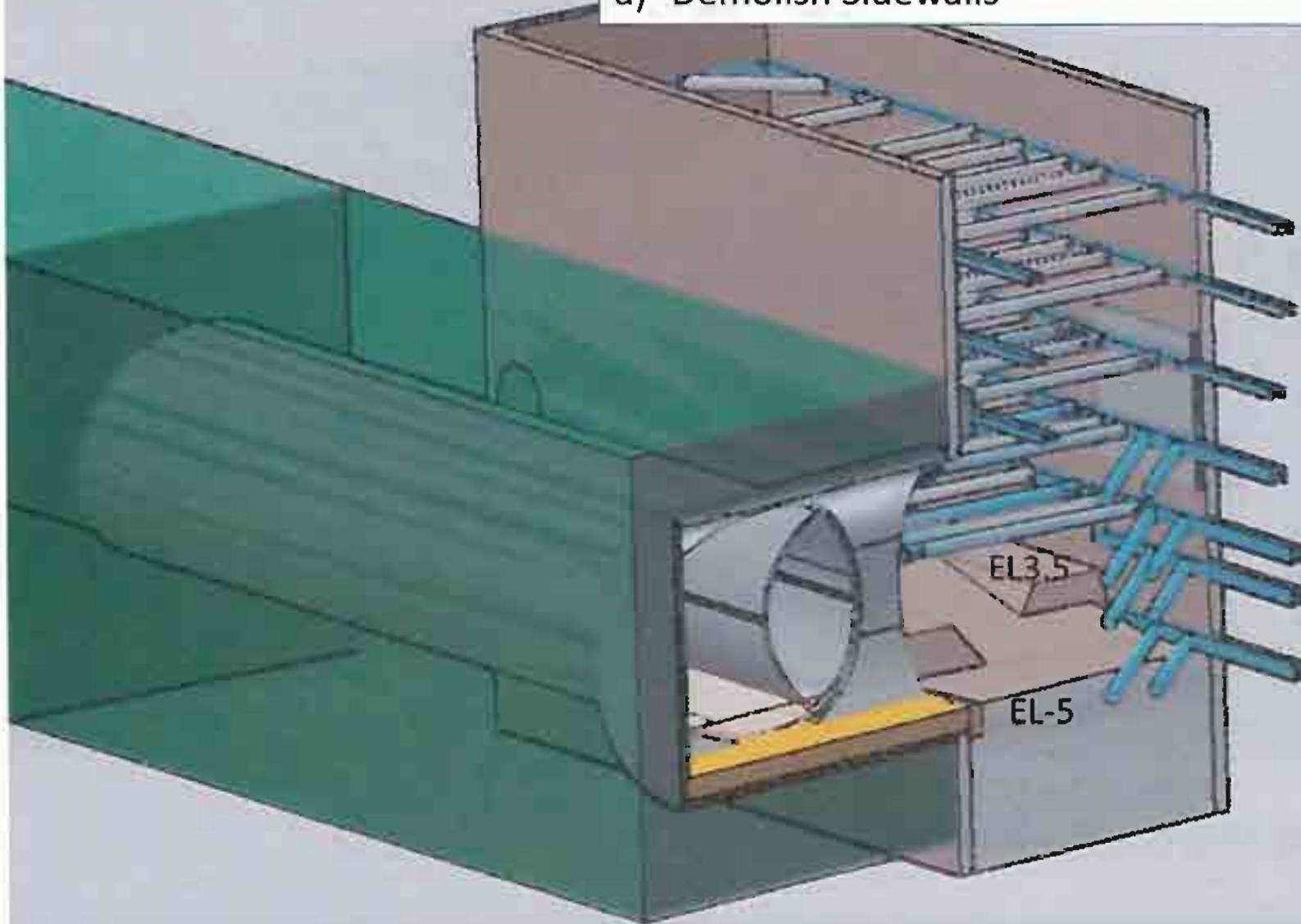

Crossover

a) Breakout & Excavate Top Heading, Bench, and Invert of Side Drifts Left & Right

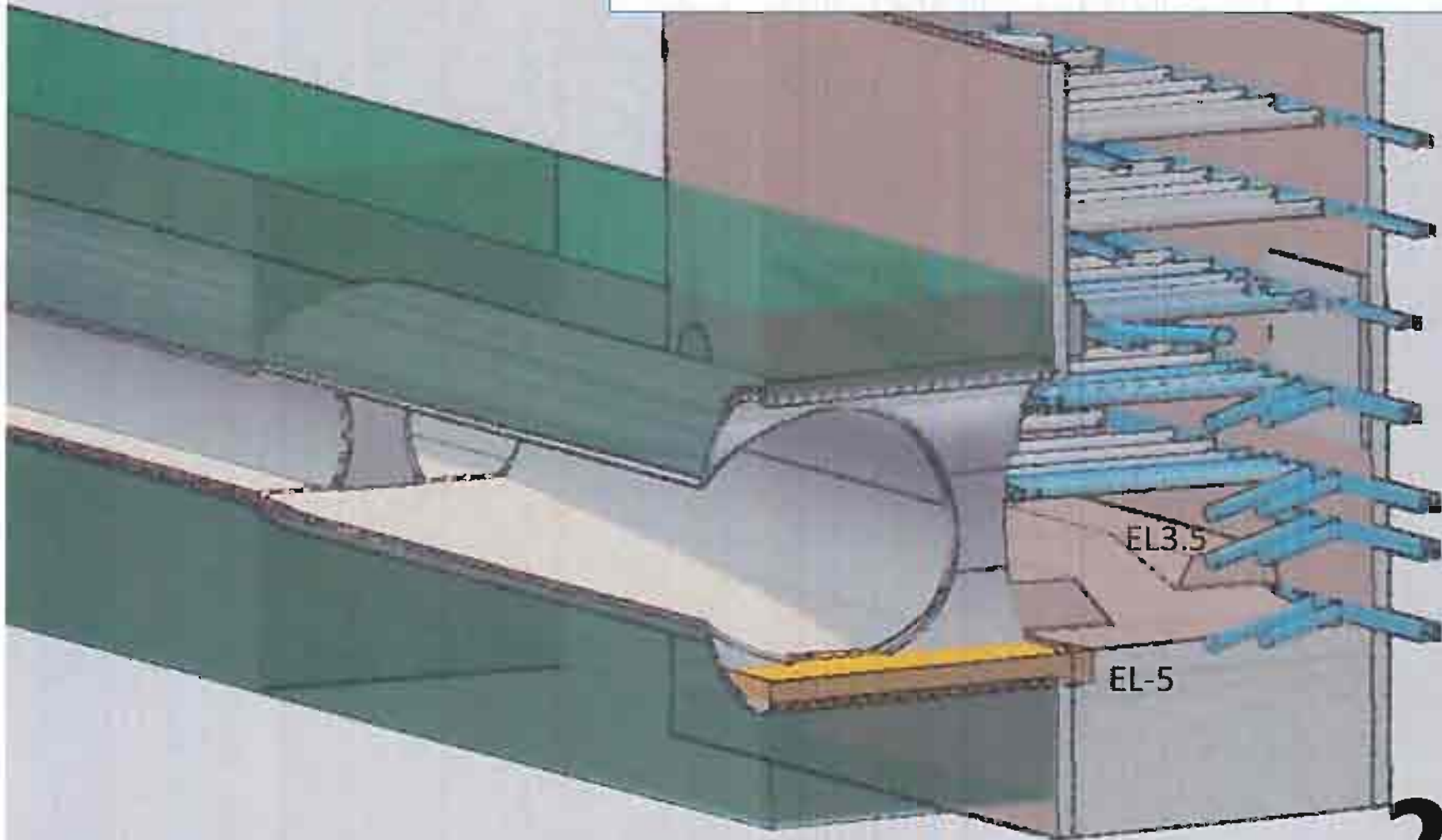

Platform North

- a) Excavate Top Heading, Bench, and Invert of Side Drifts Left & Right
- b) Advance a minimum of 40ft to allow traffic into Crossover

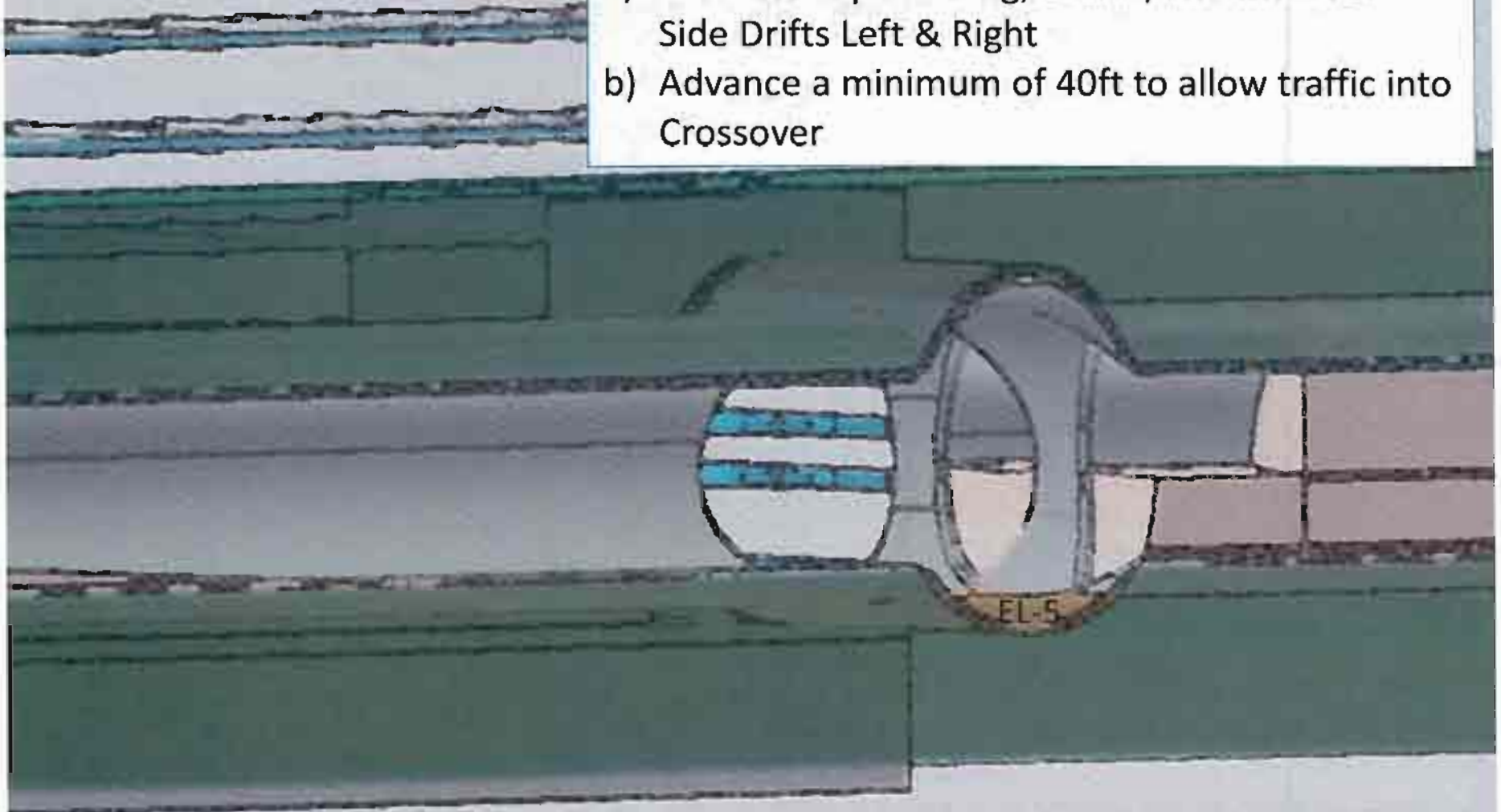

Crossover

a) Ramp inside Platform South for Crossover Top
Heading Center Drift

Platform North

a) Continue excavation of Side Drifts

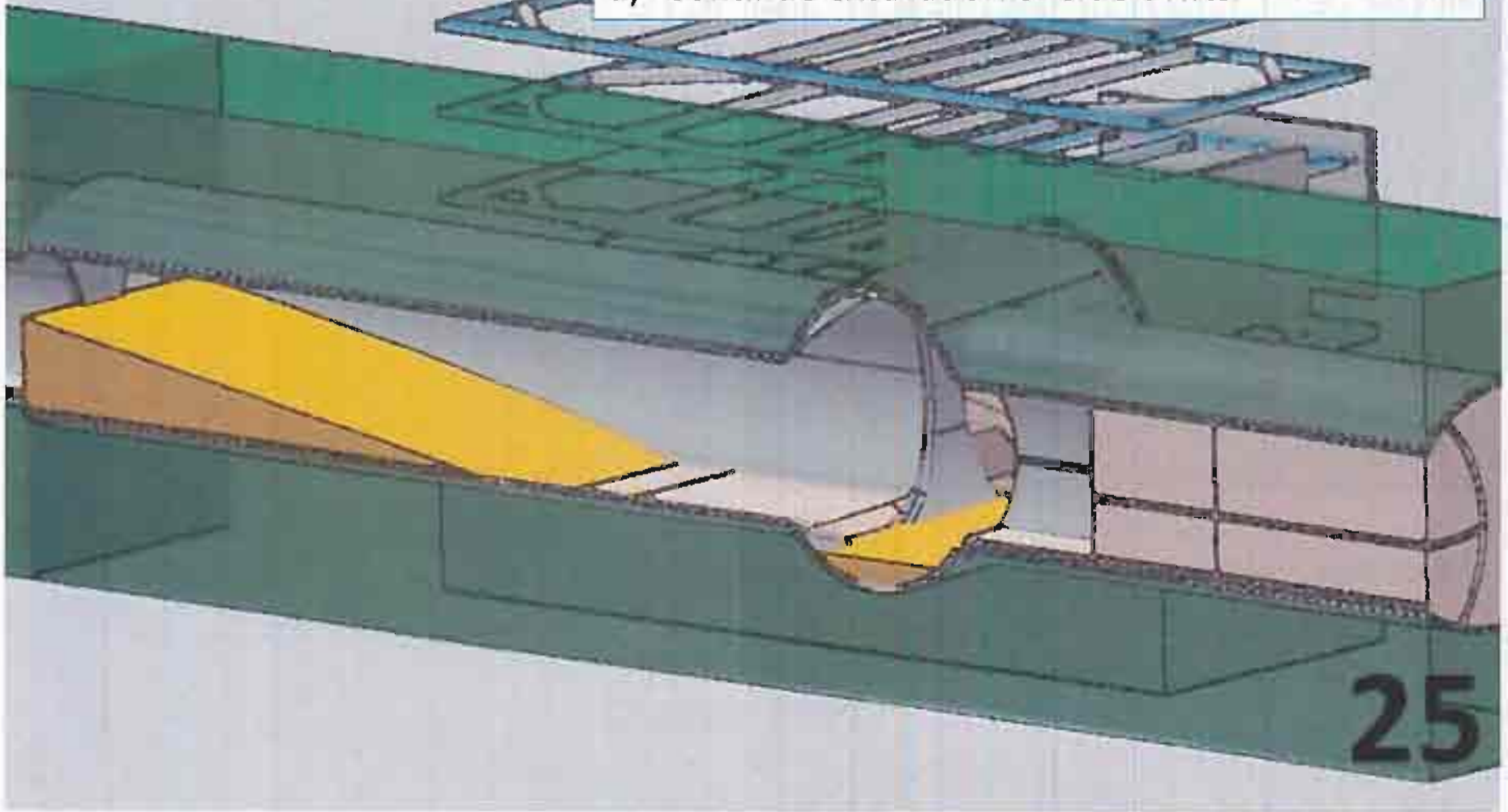

Crossover

a) Breakout & Excavate Top Heading Center Drift
Platform North

a) Continue excavation of Side Drifts

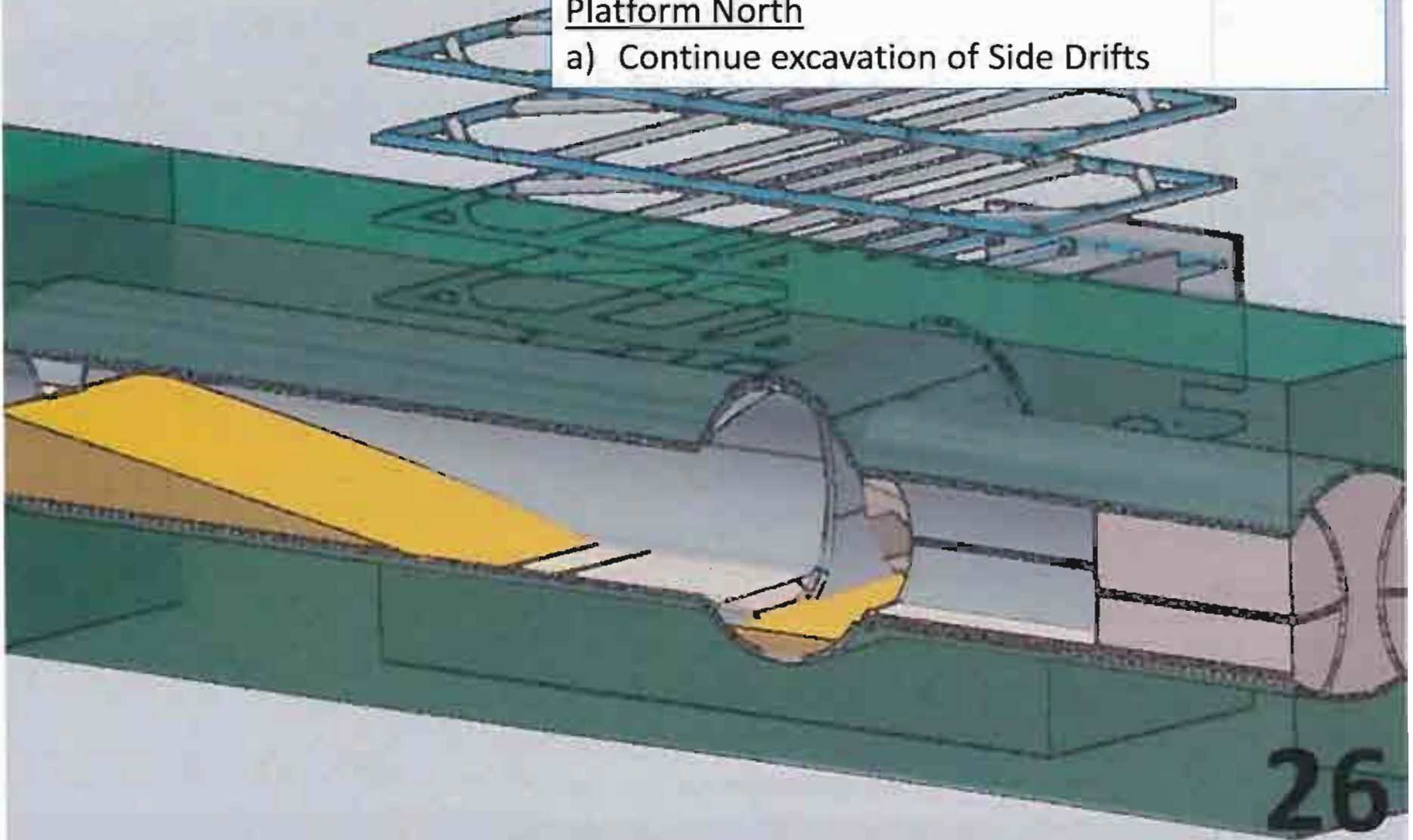

- a) Fill Headhouse up to EL22
- b) Fill in Cross Cut to EL22
- c) Replace ramp in Platform South to ramp down from Cross Cut EL22 to EL1 at Crossover

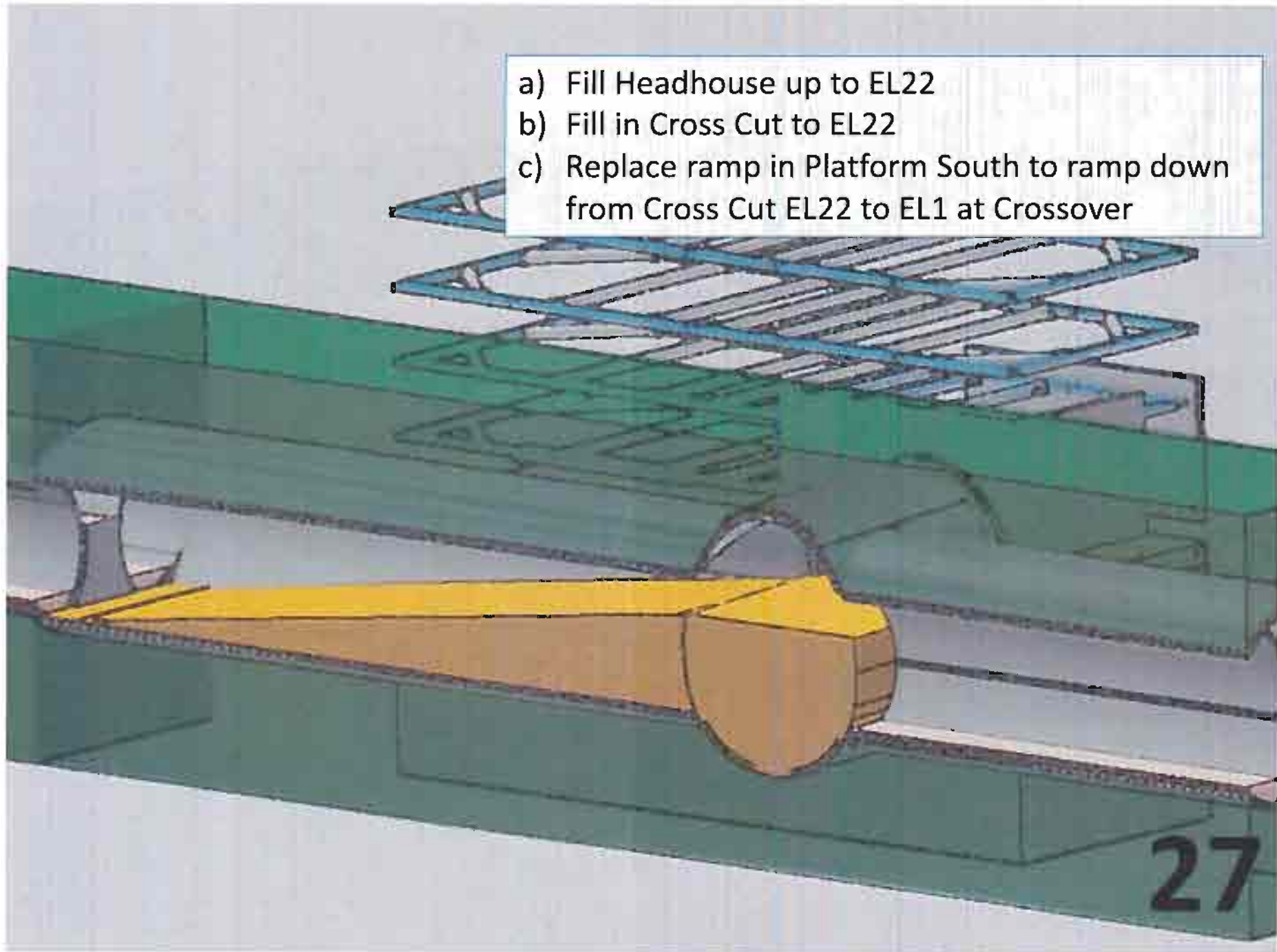

Crossover

a) Breakout & Excavate Bench/Invert Center Drift

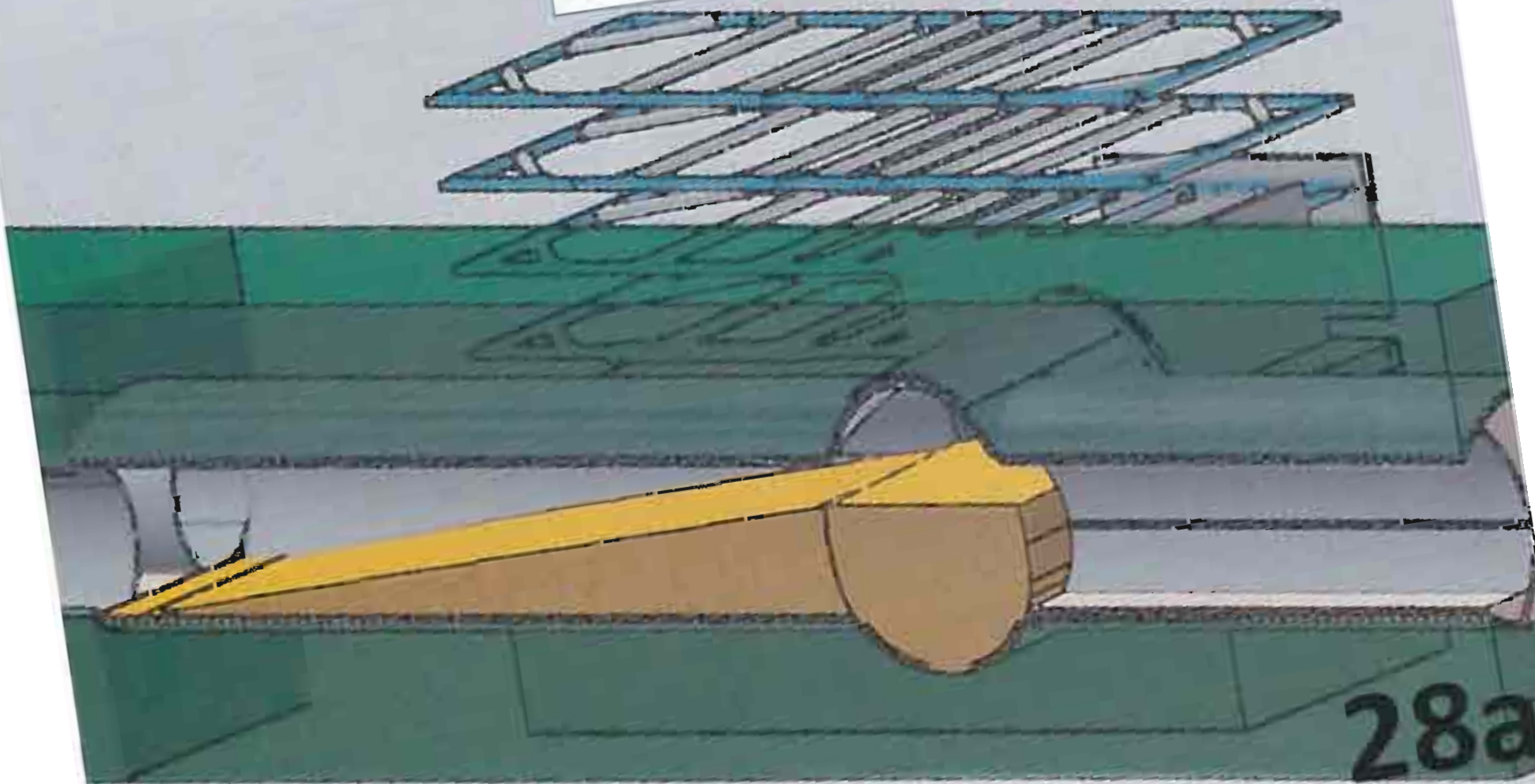

28a

Platform North

a) Breakout & Excavate Top Heading Center Drift

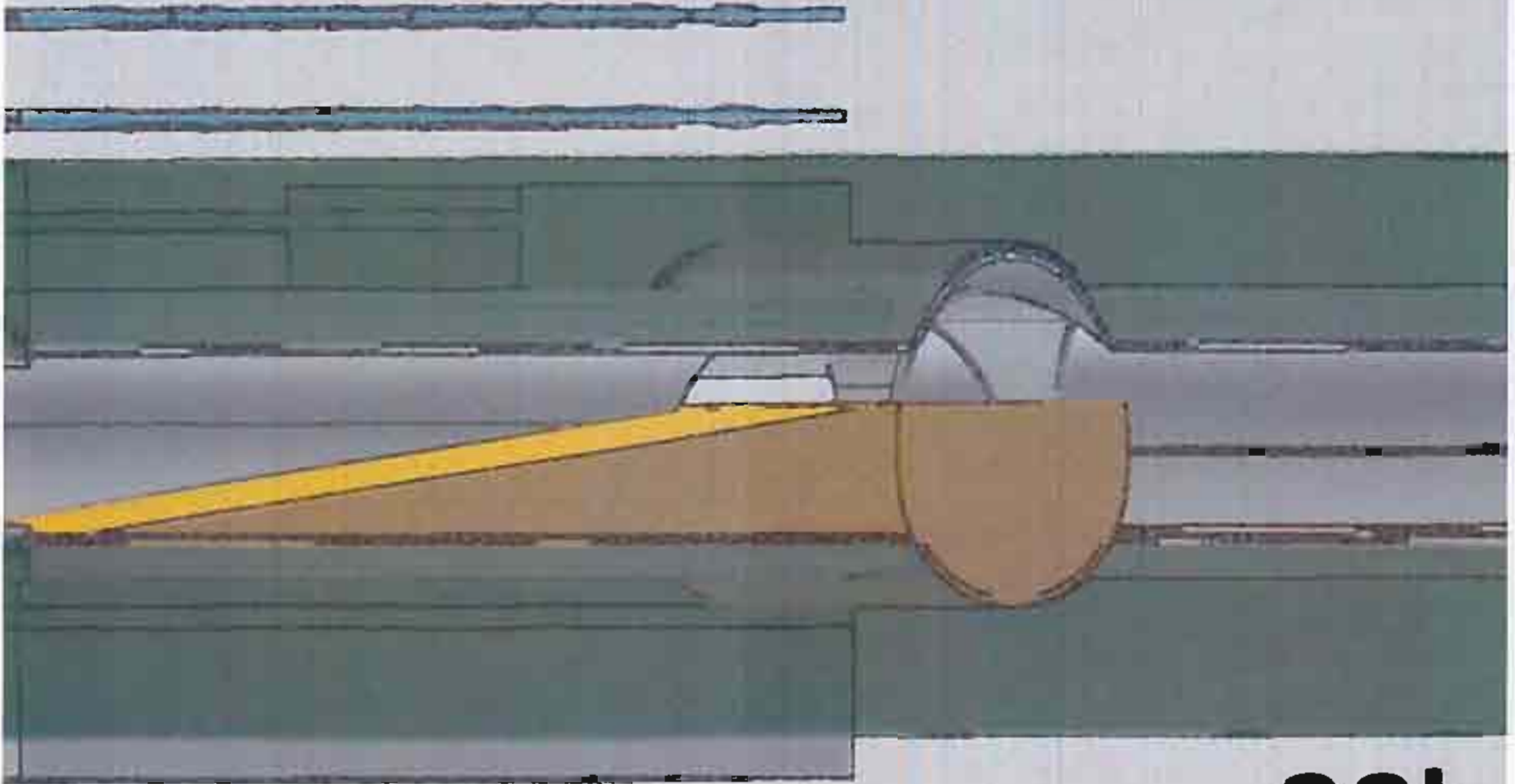

28b

- a) Lower Headhouse up to EL3.5
- b) Lower Cross Cut to EL-5
- c) Remove ramp in Platform South

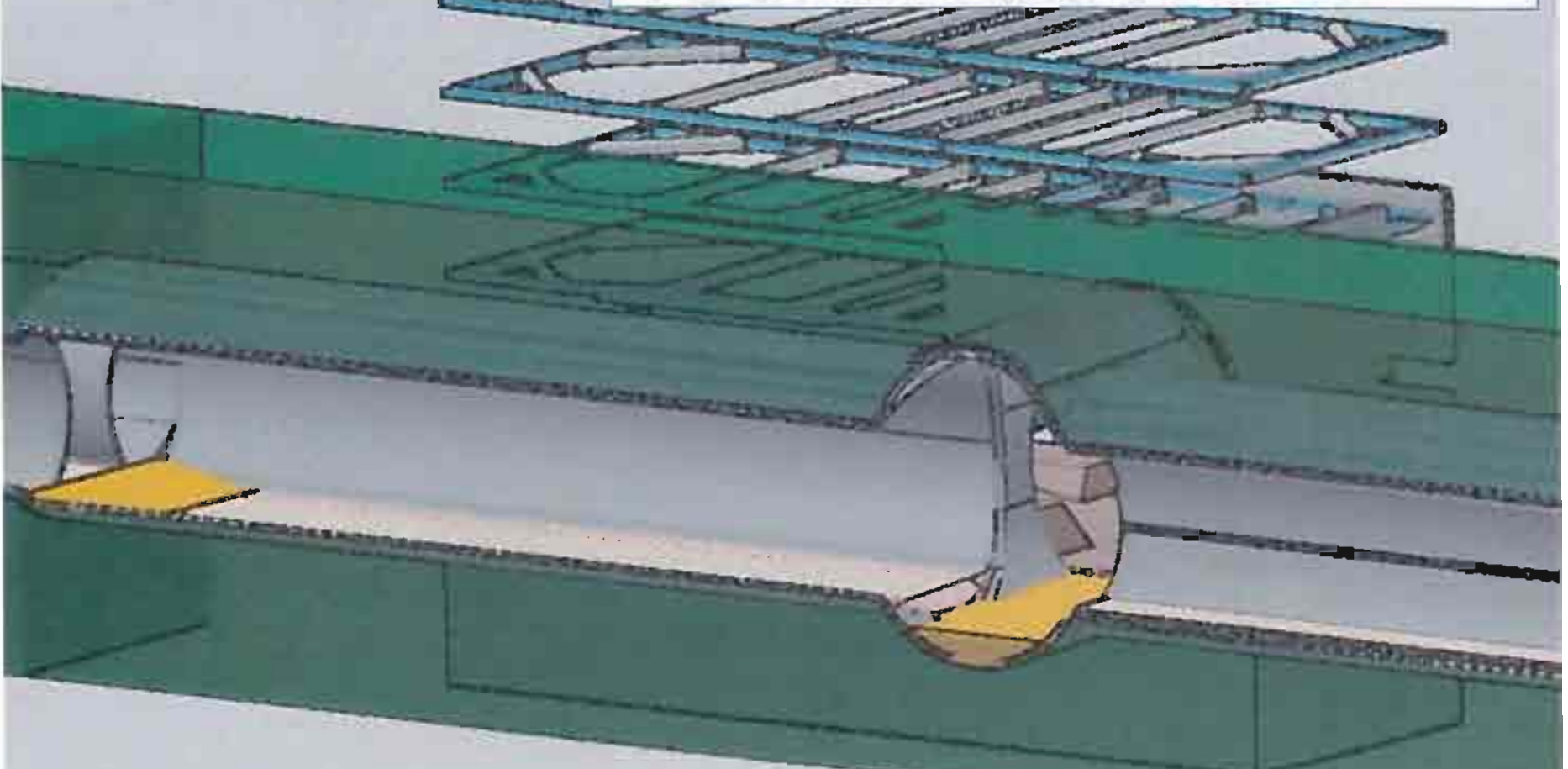

Crossover

a) Demolish Sidewalls

Platform North

a) Breakout & Excavate Bench/Invert Center Drift

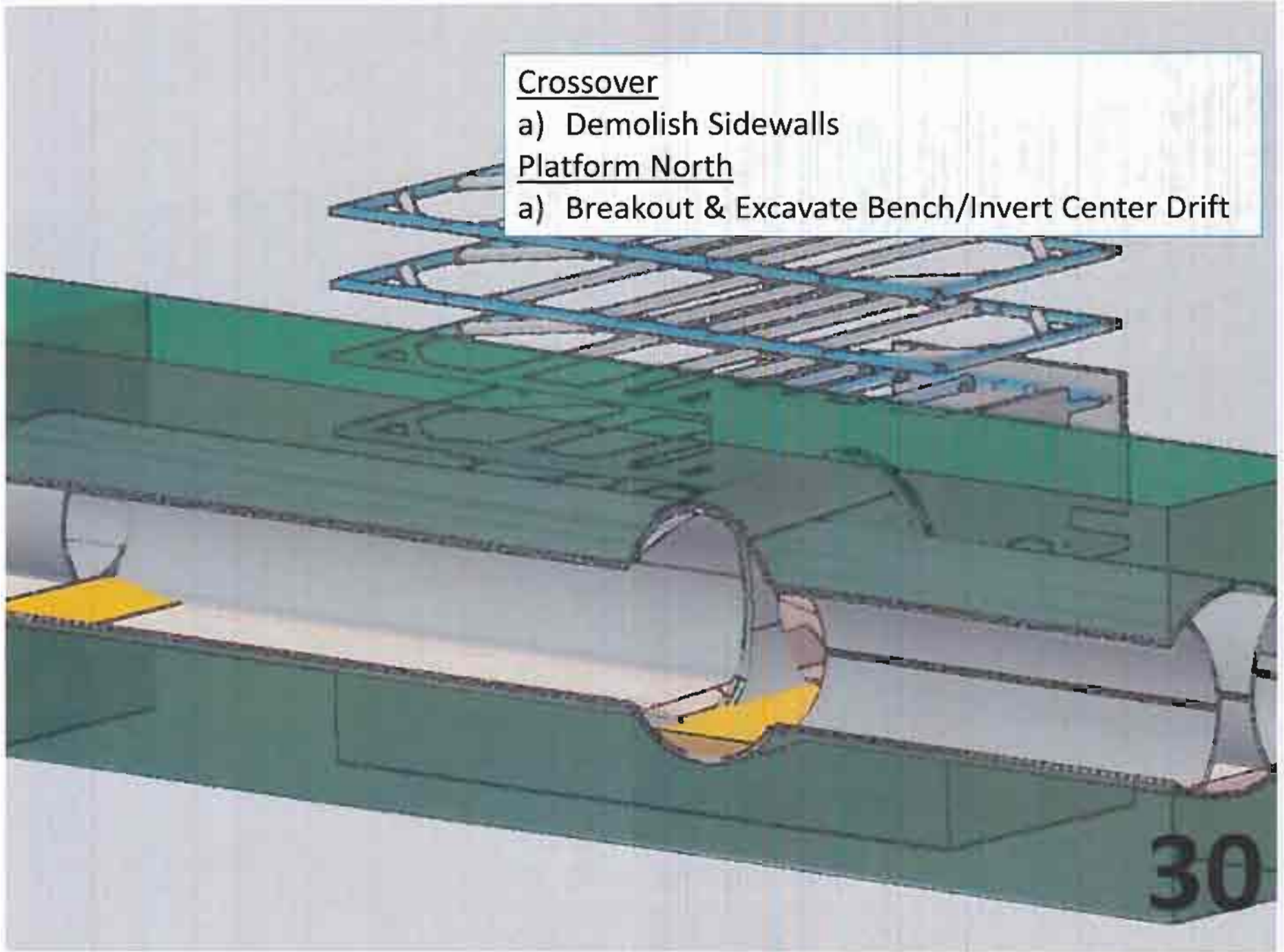

Crossover

a) Smooth Arch, Repair/Cleanup Invert, & Smooth Invert

Platform North

a) Demolish Sidewalls

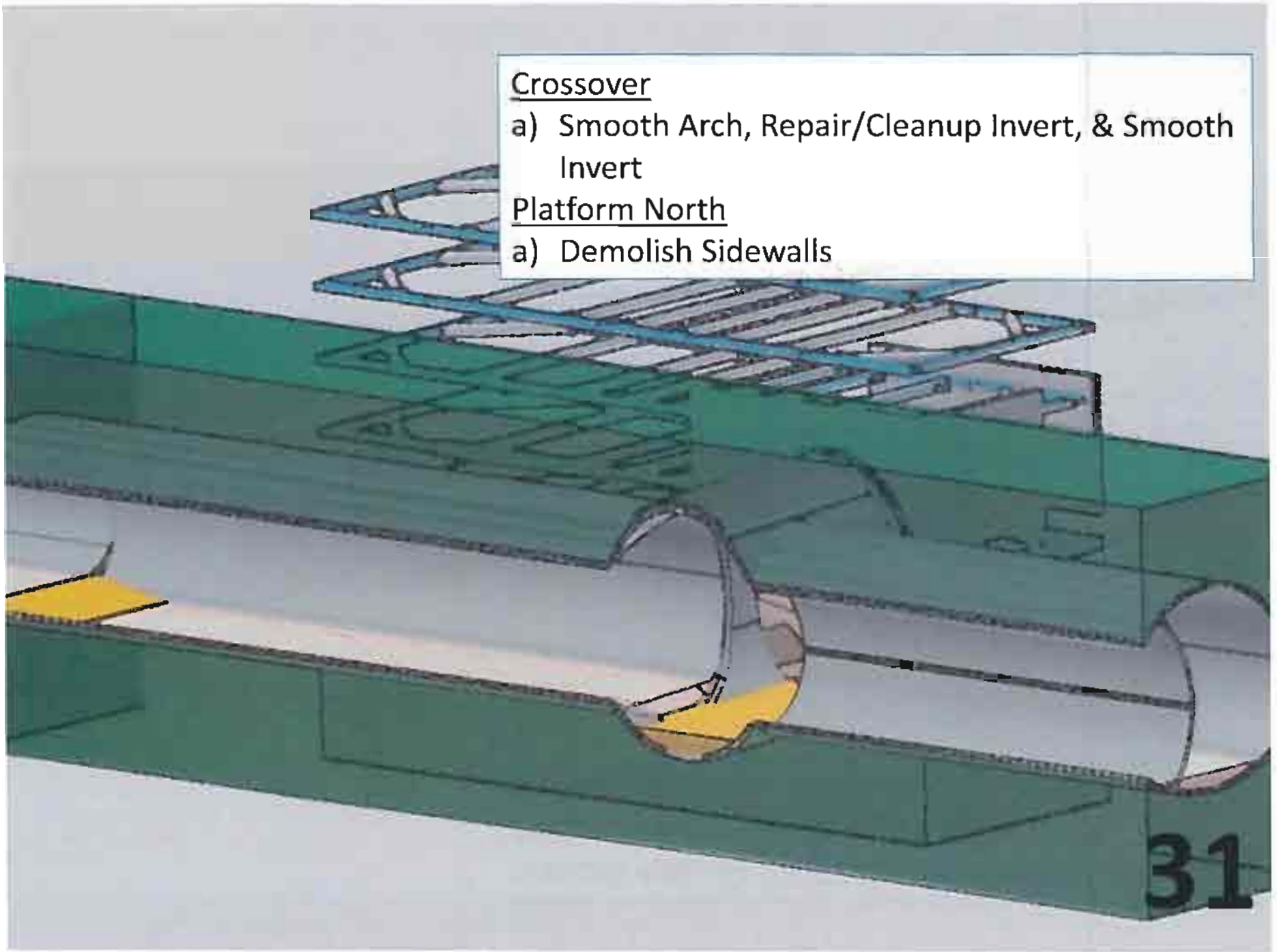

Smooth Arch, Repair/Cleanup Invert, & Smooth Invert in caverns working out towards the Headhouse.

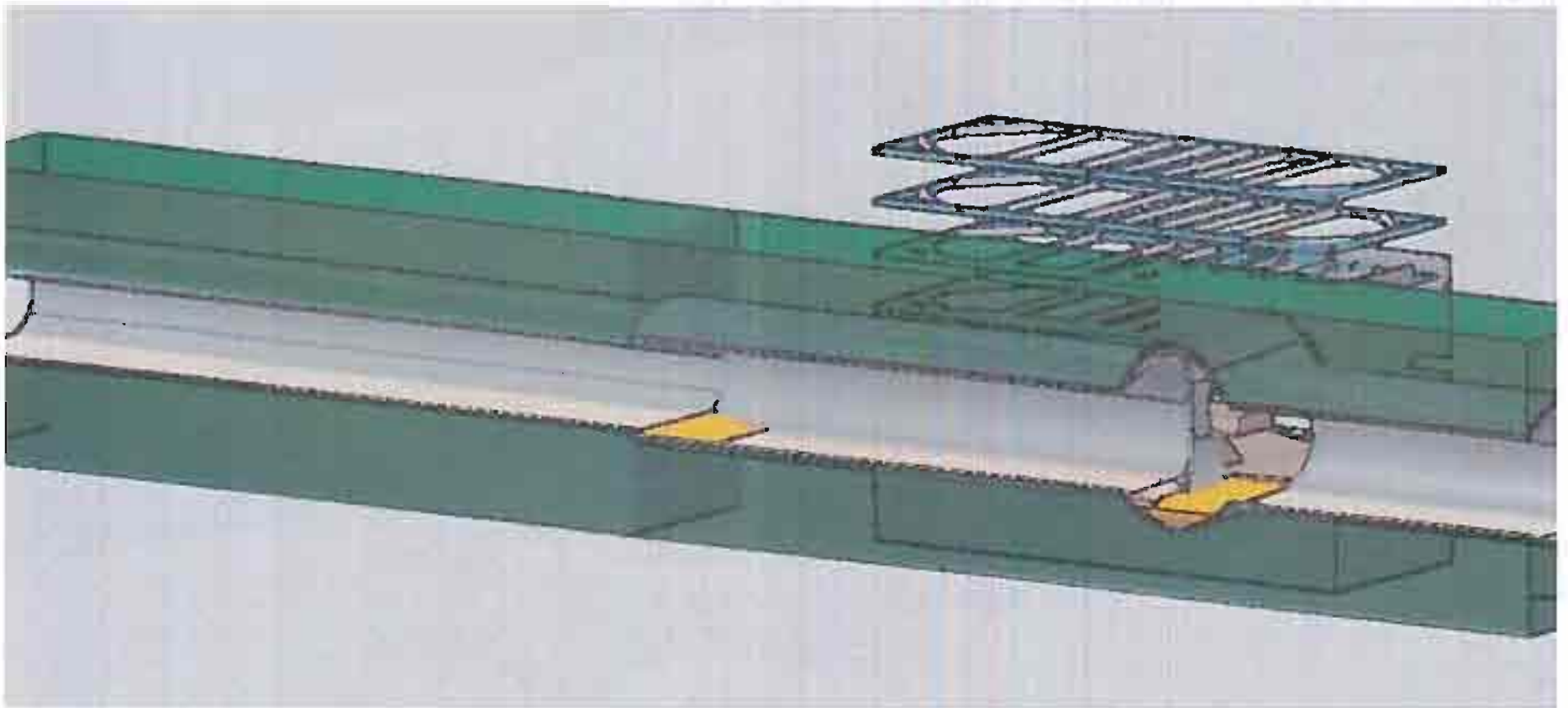

End

Connecting people. Connecting Communities.

* Trend	Date	Title	Status	Reason	PCC	COR	Value	Remark	CMod No.
00001	11/12/13	CTS-FACO #1 Potholing @Stockton&Was	CLO	Unforeseen Condition			\$13,000	Field work completed. TPC to submit FACO Summary. Included in Contract Modification No. 04	
00002	12/6/13	STS FACO #15 Add. ATT Manhole, PB	CLO	Private Utilities	6		\$625,208	Contract Specifications 33 41 10, 2.04 and 3.05 specified that all manholes and pullboxes are to be furnished and installed by AT&T. However, AT&T requested that these manholes and pullboxes be installed by the Contract 1300 contractor pending AT&T approval of a fair and reasonable cost. - PCC #6 issued to TPC. - Cost shown is Contractor's proposal. Presented to CMB on 11/20/13 and approved on 7/2/14 for \$625,208.40. CMod is forthcoming.	
00003	12/11/13	CTS Auth. Compensate Contr Traffic	CLO	Private Utilities			\$0	This work was not performed.	
00004	12/11/13	CTS Liquidated Damages Failure Traf	OPN	Other			(\$3,500)	On November 26, 2013, Tutor Perini workers closed Washington Street earlier than the approved as noted Traffic Control Plan allowed. Submittal 01 55 26.54-010 clearly stated the road is to be closed at 8:00 pm Tuesday, November 26th, 2013. Additionally, at 4:50 p.m. Monday, November 25 an e-mail message was sent to Brett Chabert and Gabe Bautista which included the time of the closure, and authorization to procure Police Officers for the closure. The police officers showed up at 8:00 pm November 26th, 2013 for the scheduled closure. Assessment of LD's per MTA discretion.	
00005	1/17/14	UMS Geoprobe Credit	CLO	Other	7		(\$30,320)	Description of PCC: Credit from the Contractor for not performing and handling six (6) core samples. The locations of the six cores were to be determined by an Archaeologist, according to field conditions, and were to be located within the UMS Station footprint. Depth of cores were to be drilled (at a minimum) to 60' below existing ground surface.	
00006	1/22/14	STS Traffic Signal RFIs	OPN	Errors and Omissions			\$150,000	Contractor found various discrepancies in the Contract ET drawings related to traffic signals. RFIs were submitted and responded to clarify the discrepancies. RE to revise ET drawings and issue PCC. Cost shown is rough order magnitude.	
00007	3/7/14	CTS-FACO #2 Connecting (E) Ductbank	OPN	Private Utilities			\$0	Field work completed. TPC to submit FACO Summary	
00008	3/7/14	CTS-FACO #3 Enlarge Excavation SFWD	CLO	Other			\$10,000	Field work completed. TPC to submit FACO Summary. Included in Contract Modification No. 04	
00009	3/7/14	CTS-FACO #4 Joint Trench Unid. Cond	OPN	Private Utilities			\$0	Field work completed. TPC to submit FACO Summary.	
00010	3/10/14	CTS-FACO #5 Unidentif 3" Metal Pipe	OPN	Private Utilities			\$0	Field work completed. TPC to submit FACO Summary.	
00011	3/10/14	CTS-FACO #6 TC for AWSS line Passin	CLO	Private Utilities			\$5,000	Field work completed. TPC to submit FACO Summary. Included in Contract Modification No. 04.	
00012	3/10/14	CTS-FACO #7 Relocate AWSS Fire Hydr	CLO	Unforeseen Condition			\$10,000	Field work completed. TPC to submit FACO Summary. Included in Contract Modification No. 04.	
00013	3/10/14	CTS-FACO #8 AWSS Line inside Sewer	CLO	Unforeseen Condition			\$0	This FACO was rescinded. TPC did not perform.	
00014	3/10/14	CTS-FACO #9 Add Traffic Signage @Po	CLO	Owner Directed CIP			\$1,000	Field work completed. TPC to submit FACO Summary. Included in Contract Modification No. 04.	

Trend	Date	Title	Status	Reason	PCC	COR	Value	Remark	CMod No.
00015	3/10/14	CTS-FACO #10 NEW AWSS Fire HydrantW	CLO	Unforeseen Condition			\$65,000	Field work is ongoing. Included in Contract Modification No. 04.	
00016	3/10/14	CTS-FACO #11 Relocate AWSS Fire Hyd	CLO	Owner Directed CIP			\$25,000	Field work is ongoing. Included in Contract Modification No. 04.	
00017	3/10/14	CTS-FACO #13 Remove a Water-Filled	CLO	Private Utilities			\$1,000	Field work completed. TPC to submit FACO Summary. Included in Contract Modification No. 04.	
00018	3/10/14	STS FACO #16 Mitigate Subsurface	OPN	Unforeseen Condition			\$0	Found pre-existing voids underneath roadway that caused streetbase to settle and collapse after saw-cutting operation. Cost to be paid under contract allowance.	
00019	3/10/14	STS FACO #17 R/D Subsurface Layers	OPN	Unforeseen Condition			\$0	Contractor found existing sub-surface layers of concrete about 12" below ground surface during potholing on 4th Street between Bryant and King. Cost to be paid under contract allowance.	
00020	3/17/14	YBM FACO #12 Buried concrete wall	OPN	Unforeseen Condition			\$0	Presented to CMB 3/12/14 NTE \$15,000 - Agreed. Increased NTE from \$15,000 to \$20,000 at CMB 4/9/14 - Agreed. Work complete 5/2/14 for guidewall construction. Wall will be encountered again when station excavation begins. Tutor has yet to submit bill. Will be paid under Allowance Item 13.	
00021	3/17/14	YBM FACO #14 Abandoned sewer not	OPN	Unforeseen Condition			\$0	Presented to CMB 3/12/14 NTE \$10,000 - Agreed. Work completed on 3/6/14. Tutor has yet to submit bill. Will be paid under Allowance Item 13.	
00022	3/31/14	UMS-FACO#19 Street Light at Stockto	OPN	Unforeseen Condition			\$0	Letter 134 formally transmitted FACO #19 directing the Contractor to remove the conduit and feeder to the combination street signal and light pole at the southwest corner of Stockton and O'Farrell. The Contractor has stated that the combination street light at the southwest corner of Stockton and O'Farrell streets was not shown on the street light drawings. SFMTA clarified that regardless of what appurtenances were on the pole, the pole was shown to be removed on drawings (pavement demo) PD-105 and (electrical) ET-104. The Contractor was correct that the conduit and feeder supplying the street light are not shown on any drawings. PG&E, SFPUC, and Sustainable Streets have not claimed ownership of the conduit and its feeder.	
00023	4/2/14	STS-FACO #20 Add'l Soil Testing Req	OPN	Owner Directed CIP			\$5,000	Contract Specifications 02 81 00.56 required the project to comply with the San Francisco Public Health Code Article 22A (Maher Ordinance). However, pesticides and chromium +6, which were required by the Landfill Facilities such as Baylands and Potrero Hills, were not included in the Maher Ordinance testing requirements. Cost shown is RE's best guesstimate.	
00024	10/24/13	UMS Grade A913 Gr 70 W Shapes	CLO	Other		2	\$626,780	See COR 002, Change Management issue "Grade 50 Steel inLieu ofA913 Grad70" for relevant information.	
00025	4/18/14	CTS-COR1 Utility Confl at WD Tie-In	CLO	Unforeseen Condition		1	\$15,662	COR #1, Negotiation between SFMTA/TPC. TPC to update the amount.	
00026	4/17/14	CTS COR 6 Sewer Line Demo at Washin	OPN	Errors and Omissions		6	\$43,616	MTA agreed to meet to discuss original \$ amount. In IRL process.	
00027	4/17/14	CTS COR4 Insp of Sewer Culverts on	CLO	Errors and Omissions		4	\$1,280	COR under review.	
00028	4/17/14	CTS-Deletion of Ductbank on Stockto	CLO	Other		1	(\$84,018)	Contractor provided a credit proposal in the amount of -\$84,018.00.	
00029	4/18/14	YBM FACO #18 Add analytical tests	OPN	Other			\$5,000	Test for SVOCs, organic pesticides and hexavalent chromium in 3 remaining soil profile borings. Tutor has not submitted bill. Will have to be paid through Change Order.	

Trend	Date	Title	Status	Reason	PCC	COR	Value	Remark	CMod No.
00030	4/18/14	YBM FACO #21 Buried timber piles	OPN	Unforeseen Condition			\$0	Merit presented to CMB 4/16/14 - Agreed. Pile extraction completed on 5-5-14. Tutor has not submitted bill. Will be paid by Allowance Item 13.	
00031	4/18/14	Concrete obstructions AWSS work	OPN	Other			\$0	Investigation work performed 5/6/14. Obstruction was discovered to be a thick (18-20") street section. SFMTA believes this issue is without merit. However, Tutor has not closed this issue.	
00032	4/18/14	YBM FACO #22 potential contam soil	OPN	Other			\$15,000	Issue presented to CMB 4/16/14 - Agreed. Work completed but will resume when begin headhouse excavation. If merit determined will be paid by Allowance Item 4.	
00033	4/18/14	CTS-DSCBrick Requiring Hand Work	DENI	Unforeseen Condition			\$0	MTA denied	
00034	4/18/14	CTS-DSC Unanticipated Vault Obstruc	DENI	Unforeseen Condition			\$0	MTA directed to not expend resources.	
00035	4/18/14	CTS-DSC Unkown Conduits on Washingt	OPN	Unforeseen Condition			\$0	Costs captured by FACOs.	
00036	4/18/14	CTS-DSC ContamSoil COR#7	OPN	Unforeseen Condition		7	\$3,743,672	MTA requested backup for S&S Trucking costs.	
00037	4/18/14	CTS-Panel 45 DSC Obnoxious Odors	OPN	Unforeseen Condition			\$0	TPC put MTA on notice.	
00038	4/22/14	UMS BART Entry Hazmat Abatement	DENI	Unforeseen Condition		8	\$86,189	<p>Tutor maintains that the existing hazmat were not disclosed at bid and that they are a differing site condition and extra work. They present their hazmat survey to substantiate their position.</p> <p>Letter 176 cites the spec references to the environmental reports and provides copies of the environmental reports findings, which are consistent with the Contractor's hazmat findings. Allowance Item No. 5 states that payment will not be made for work identified as containing hazardous materials in the specifications. The letter also points out that the Contractor waited until 7 months after their hazmat survey was completed before submitting their NDSC (which is required 24 hours after they were aware of the supposed problem.)</p> <p>NDSC and COR were denied via Letter 176. TPC responded via letter 166 that it never agreed to provide its internal bid documents.</p> <p>Letter 226 was issued on June 18 to TPC restating TPC's commitment to providing the documents, and also requested the activity durations so that SFMTA could develop its engineer's estimate.</p> <p>At the PM/CM meeting on 7/7/14, verbal direction was given to issue a FACO to TPC to proceed with the abatement at Ellis Street. To date, TPC has not provided the requested backup to SFMTA (including the activity durations).</p>	
00039	4/23/14	CTS-DSC Harder Rock	NEW	Unforeseen Condition			\$0	Potential claim.	
00040	4/23/14	PCC #10 230KV Casing at Bryant/4th	NEW	Private Utilities		10	\$138,000	<p>PG&E wants Central Subway to install steel casing next to existing 230kV at 4th/Bryant.</p> <p>-PCC #10 issued to TPC on 4/23/14. Cost shown is rough order of magnitude.</p>	
00041	4/24/14	UMS NDSC Macys Mens Canopies	OPN	Unforeseen Condition			\$0	<p>Tutor maintains that they could not have known the extent of the work involved with the canopy removals. They did not properly evaluate the canopies at bid time, and did not review the as-built drawings to determine the scope of work.</p> <p>Issue remains open as the canopy submittals (and the work involved) have not been approved and the full extent of the work has not been fleshed out. This will affect the work to install the Type J piles at the emergency egress stairs near Macy's Mens.</p> <p>NDSC was denied on Letter 69.</p>	

Trend	Date	Title	Status	Reason	PCC	COR	Value	Remark	CMod No.
00042	4/24/14	UMS NDSC Struc Concrete Beams Pile	DENI	Unforeseen Condition			\$50,000	Tutor encountered the structural basement roof left over from Contract 1251, and claim that it is not shown on the drawings. The pavement demo indicate notes "B&9" that structural concrete and steel were to be demolished. The 1251 reference drawings show the extent of the work. NDSC was denied on Letter 71. However, the cost could potentially be submitted as a claim.	
00043	4/24/14	UMS ND Becho Pile Concrete Mix	DENI	Other			\$0	Tutor/Becho did not provide any evidence or logic to substantiate the basis for the delay. The CPM baseline schedule was not consistent with Becho's claim that the denial of their concrete mix design (due to permeability not meeting spec requirements). ND was denied on Letter 116.	
00044	4/24/14	UMS ND Ellis Street Access	DENI	Other			\$0	TPC claiming a delay to their schedule for BIH's late departure from Ellis St. TPC did not coordinate with BIH. TPC did not formally request access to Ellis St and did not formally notify SFMTA of potential delay. ND was denied on Letter 101.	
00045	4/24/14	UMS NDSC #1 Becho Unknown Obstruct	DENI	Unforeseen Condition			\$3,500	Tutor/Becho failed to prove that the sub-basement walls and footings they encountered were unexpected or unforeseen. NDSC was denied on Letter 90. Tutor resubmitted. NDSC denied a second time via Letter 99.	
00046	4/24/14	YBM 20" water conflict east wall	CLO	Other			\$0	Received RFI 530 on 4/23/14 of potential issue. Water line shown correctly in contract dwgs. SFWD will perform early shutdown of water line. It is anticipated there is no extra costs as this work was within scope with SFWD.	
00047	4/24/14	UMS NDSC #2 Becho BasemntWall Obst	DENI	Unforeseen Condition			\$3,500	Tutor/Becho failed to prove that the sub-basement walls they encountered were unexpected or unforeseen. They are shown on the ES drawings, which also require that the existing bldg components be removed prior to pile wall installation. NDSC was denied on Letter 91. Tutor resubmitted. NDSC denied a second time via Letter 100.	

Trend	Date	Title	Status	Reason	PCC	COR	Value	Remark	CMod No.
00048	4/24/14	UMS ND Muni OCS Pole at Market	OPN	Other			\$23,000	<p>The phasing for the OCS pole shown in the OCS drawings is intended by the designer to aid in the roof beam installation. It is believed that the Contractor wishes to reconfigure the OCS before pile installation begins. The Contractor's phasing results in conflicts between several Type E Piles and the TEMP OCS pole and associate guy wires. We believe that if the Contractor installs most of the Type E Piles, then stops pile installation activity to reconfigure and install the TEMP OCS pole and cabling, that the Contractor will not have all of the problems that they claim.</p> <p>SFMTA has responded on Letter 110 that TPC needs to provide its sequence for construction and installation of piles at Market & Ellis St. TPC verbally stated that they will consult with their sub-contractor, Becho, about alternative drill rig positions to facilitate the pile installation. The Contractor also stated that they will be pot holing to investigate whether another location for the temporary pole is possible to meet the Contractor's desired sequencing. Letter 110 goes on to state that when the above information is provided to SFTMA another meeting will be held to discuss and hopefully resolve this issue.</p> <p>Potholing revealed additional utilities and conduits conflicting at the original (design) location for the TEMP OCS pole. Additional meeting held on 6/25/14, and it was agreed that another location would be investigated for potholing. The RE agreed to pay for the additional potholing on Force Account.</p> <p>Verbal direction provided during the PM/CM Monday morning meeting on 7/7/14 to authorize CSDG to proceed with foundation design for the alternative TEMP OCS pole location. Verbal direction also stated that when foundation design was provided to TPC, that the letter would clearly state that SFMTA CSP would reserve its right to back charge TPC for the design costs of the TEMP OCS pole foundation.</p> <p>MUNI OCS was provided the Phase 1 and Phase 2 configurations by 1300 CM Team. OCS provided loadings for OCS cable supports. Loading design was forwarded to CSDG on 7/15/14.</p>	
00049	4/24/14	UMS NDSC #3 Becho C Pile Obstruct	DENI	Unforeseen Condition			\$3,500	<p>Originally, the ROM cost for this issue was only for the cost to suspend then remobilize the pile subcontractor while the work to perform the temporary OCS installation is completed. It is contemplated that the costs could be higher due to the need for a deeper foundation. FACO #25 was issued to cover potholing.</p> <p>Tutor/Becho failed to prove that the abandoned utilities they encountered were unexpected or unforeseen. Becho (subcontractor) states that it had been agreed that all utilities would be relocated before start of work. SFTMA had made no such representation in the 1300 contract.</p>	
00050	4/24/14	UMS NDSC #4 Becho Obstruct C Pile	DENI	Unforeseen Condition			\$3,500	<p>NDSC was denied on Letter 127.</p> <p>Tutor/Becho failed to prove that the abandoned utilities they encountered were unexpected or unforeseen. Becho (subcontractor) states that it had been agreed that all utilities would be relocated before start of work. SFTMA had made no such representation in the 1300 contract.</p> <p>NDSC was denied on Letter 128.</p>	

Trend	Date	Title	Status	Reason	PCC	COR	Value	Remark	CMod No.
00051	4/24/14	UMS NDSC #5 Becho Obstruct C Pile	DENI	Unforeseen Condition			\$3,500	Tutor/Becho failed to prove that the abandoned utilities and concrete they encountered were unexpected or unforeseen. Also failed to study the Geotech report which stated that the wood, brick and concrete objects found in this strata were to be expected when performing subsurface work, or the contract drawings which show the concrete walls. NDSC was denied on Letter 131.	
00052	4/24/14	UMS NDSC (e) Waterline Depth	DENI	Unforeseen Condition			\$2,500	Tutor/Valverde used a saw cut to cut deeper than the 8" thick street (= 2" A/C wear surface + 6" Concrete Base). The saw cut blade cut through the water line, causing water leak out. It is improper to use a sawcut thicker than the depth of the street. NDSC was denied on Letter 139.	
00053	4/24/14	UMS NDSC #6 Becho Obstruct C Pile	DENI	Unforeseen Condition			\$3,500	Tutor/Becho failed to prove that the abandoned utilities they encountered were unexpected or unforeseen. It was indicated in the specifications that they were expected to encounter abandoned utilities. NDSC was denied on Letter 141. Tutor resubmitted with supplemental information. NDSC denied a second time via Letter 145.	
00054	4/24/14	UMS NDSC Imprope TrafficSignal Line	DENI	Unforeseen Condition			\$3,500	Tutor/Valverde ran their sawcut blade too deep and hit/cut a traffic signal conduit and feeder that was about 8" to 12" below the underside of the slab. The traffic signals were knocked out of service, and crews had to wait until the signal shop was on site to perform the repairs. Claiming for compensation to repair and restore the signals due to their non-code compliant depth NDSC was denied on Letter 168. Traffic Signal Restoration Protocol provided via Letter 168.	
00055	4/24/14	UMS ND & COR 3 AWSS Hydrant	DENI	Unforeseen Condition			\$8,353	Tutor maintains that the AWSS drawings only show the AWSS lateral and not the hydrant to be removed. They maintain that the lack of note for removal of the AWSS hydrant means that it is extra. The PD drawings show the AWSS Hydrant to be removed. ND was denied on Letter 103 for CO for the Work to remove the AWSS hydrant at the Northwest corner of Stockton & O'Farrell. Tutor/Valverde resubmitted request. It was denied a second time via Letter 126. An issue "resolution ladder" meeting was held between the RE and Valverde. The RE ONLY agreed to recommend payment for just rigging, hoisting, and trucking the hydrant and associated riser. The draft letter formally offering this recommendation is being circulated for review.	
00056	4/24/14	UMS NDSC #7 Becho Obstruct C Pile	DENI	Unforeseen Condition			\$3,500	Tutor/Becho have not presented findings with regard to the metal or steel obstructions being encountered being inconsistent with the language in contract that they are responsible for abandoned utility facilities. NDSC was denied on Letter 160.	

Trend	Date	Title	Status	Reason	PCC	COR	Value	Remark	CMod No.
00057	4/24/14	UMS NDSC Inadequate CDF	DENI	Unforeseen Condition			\$50,000	<p>Tutor has assumed CDF was placed under the utility relocation contract as a self-supporting back fill which would not require shoring for later work (UMS). Tutor claims that the CDF not being used 100% in several locations requires them to install shoring. They had gone from the as-builts which showed CDF 100% supporting the existing sidewalk. Shoring is in fact shown on the ES drawings as being necessary.</p> <p>NDSC was denied on Letter 163.</p> <p>TPC submitted additional analysis TPC Letter 179 on June 18, 2014.</p> <p>CSDG reviewed TPC's letter. CSDG concluded that the CDF could self support in areas that had building basements, i.e. no lateral loads.</p> <p>Per PM/CM meeting on 6/7/14, verbal authorization was granted to issue FACO for TPC to proceed with CDF repairs. FACO #30 was issued on 7/9/14 via Letter 242R.</p>	
00058	4/24/14	UMS ND TCP at O'Farrell Pile Macys	DENI	Other			\$10,000	<p>Tutor maintains that they are not required to provide 6' sidewalk access anywhere in the vicinity of Macy's Mens Store, since the north edge of the pile line is about 1'-6" from the (south) face of Macy's Mens building. The sidewalk access is a requirement of the traffic drawings. The Traffic Engineer laid out dimensioning showing that it would be possible to place a 6' walkway along the south side of the construction laydown area (within the traffic lane). Tutor denies that this is possible because this reduces the width of their fencing, constricting their laydown area's width, and will not be wide enough to fit their equipment.</p> <p>SFMTA also noted that the Macy's Canopy Removal and Storage submittal had not been approved yet. The piles cannot be installed until the canopy is removed. Non-approval of the canopy precludes Tutor from beginning work in this area.</p> <p>NDSC was denied on Letter 166.</p>	
00059	4/25/14	UMS NDSC #8 Becho Obstruct C Pile	DENI	Unforeseen Condition			\$11,000	<p>Tutor/Becho failed to prove that the steel pipe/casing they encountered was to be unexpected or unforeseen. Becho (subcontractor) states that it had been agreed that all utilities would be relocated before start of work by the 1252 Contractor. SFTMA had made no such representation in the 1300 contract.</p> <p>NDSC was denied via Letter 170.</p>	

Trend	Date	Title	Status	Reason	PCC	COR	Value	Remark	CMod No.
00060	4/28/14	UMS W Shape Wale Supports	DENI	Other			\$100,000	<p>Tutor maintains that the Response to Bidder's questions: "W Shape is only a temporary support for the wale installation, and is to be designed by the Contractor to suit their means and methods" was contractual direction to design a small (and impermanent) W Shape. They contend that during the design meeting "9/17/13" the designer's clarification that the W Shape was the only means of vertical permanent vertical support is a change to the Contract. The Contractor maintains that their engineering done so far for the permanent W Shape reveals a cost that is greater than what would be required for temporary W Shapes.</p> <p>SFTMA cited spec sections and drawing notes which require the Contractor to design the connections. Since the W Shape wale support is a part of the connection, and since the connections are the Contractor's sole responsibility, sizing the W Shape (whether temporary or permanent) is a part of the Contractor's scope of work.</p> <p>Advanced notice of COR was denied thru (SFMTA) Letter 171. TPC submitted (TPC) Letter 94 as advanced notification of pending COR for the increase in Shape of the W sections.</p>	
00061	4/30/14	UMS Tangent Pile Work Delays	OPN	Other			\$150,000	<p>Contractor has submitted two RFI's contending a defective design with respect to tolerances. Tutor shows in their RFI's what they believe are conflicts with the battered pile tips and tunnel's structural shell. They believe that the battered pile tips, in many locations, will penetrate the tunnel shell. SFMTA's continued response has been to install that there is no conflict between the battered pile tips and the tunnel and that the Contractor is to proceed with pile installation per the design documents.</p> <p>SFMTA issued Letter 132, bringing supposed Tangent Pile issue to head. TPC responded via TPC Letter 103, which SFMTA countered with Letter 155.</p> <p>The estimated value is listed only as a place holder since this work is not on the critical path, it is difficult to estimate a cost impact.</p> <p>TPC issued Letter 121, asserting that there is a 'potential' for the piles to conflict with the tunnel and expressing entitlement to a change order.</p> <p>SFMTA responded via Letter 208, rejecting the Contractor's position and directing to install the piles per contract. It should be noted that the tangent pile work began on 4/29 with no (apparent) issues as had been asserted by the Contractor.</p>	
00062	4/30/14	UMS Compensation Grout	OPN	Other			\$0	<p>Tutor has not submitted their Compensation Grouting plan, but their schedule and their direction to backfill the existing grout shaft @ Ellis St, is evidence that Tutor will not follow the compensation grout plan design.</p> <p>SFTMA has stipulated in Letters 94 and 106 that it has not received detailed compensation grouting plans for review and approval. Letter 94 describes the issues that must be addressed in the grouting plan</p>	
00063	4/30/14	UMS NDSC Hydrant N. of Geary	DENI	Unforeseen Condition			\$25,000	<p>Tutor's argues that the plans were not clear that the hydrant (& its associated lateral) had to be coordinated with the Type E Pile installation. This argument is unfounded. The drawings clearly show the hydrant lateral running over the southern portion of Pile E85, and the UD drawings note that the lateral must remain in service and must be phased/coordinated with pile installation.</p> <p>NDSC was denied via Letter 174.</p>	

Trend	Date	Title	Status	Reason	PCC	COR	Value	Remark	CMod No.
00064	5/23/14	GEN-PCC9 TP Cable & Conduit Downsiz	OPN	Owner Directed CIP	9		\$0	Reduce traction power cables from 2.4kV to 2.0kV and reduce traction power conduit from 5" GRSC/Phenolic to 4" Phenolic. (Programwide). Initially presented to CMB on 9/3/13. CMB approved PCC to TPC on 5/22/14. Potential cost savings of \$907,000.	
00065	5/2/14	STS-PG&E 6" gas re-alignment	OPN	Private Utilities			\$10,000	PG&E gas as shown in sidewalk per contract does not meet PG&E requirement. RE to issue a PCC. Cost shown is RE's best guesstimate.	
00066	5/7/14	STS-Subsurface structural wall at S	NEW	Unforeseen Condition			\$50,000	Subsurface structural wall at SW 4th/Brannan was discovered during potholing. Expected to become DSC during permanent installation. Issue to be addressed when more information becomes available during permanent installation. Cost shown is a placeholder.	
00067	5/8/14	YBMAWSS conflict with PGE vault	CLO	Errors and Omissions			\$35,000	Any costs will be forwarded to PGE. See letter to PGE dated 4/18/14. PGE responded in email on 4/21/14 discussing liability. Received ROM from Tutor on June 11, 2014. COR 010 submitted on 7/1/14.	
00068	5/29/14	CTS-DSC Hard Rock at Slurry Wall	NEW	Unforeseen Condition			\$0	Tracking work in field.	
00069	5/29/14	CTS-PCC12 AWSS Wk PGE reloctn sched	CLO	Unforeseen Condition	12		\$68,550	Scope meeting held. TPC to provide quote.	
00070	5/29/14	CTS-PG&E Scope Change at Exit Hatch	NEW	Private Utilities			\$0	Drafting PCC to present to CMB	
00071	6/3/14	UMS NDSC AT&T Conduits @ Geary St	DENI	Private Utilities			\$50,000	<p>Contractor has submitted Notice of Differing Site Condition regarding AT&T conduits at Geary Street (Geary/Stockton intersection). The Contractor contends that the existing duct bank is a nested, unorganized array of custom sweeps, installed in violation of the City and Contract Specifications. Tutor alleges that this disorganized mass of conduits crossing the pile line cannot be shifted, as necessary, to allow the piles to be installed.</p> <p>SFMTA forwarded TPC's letter on 5/21/14 to AT&T (Huan Hyunh).</p> <p>SFTMA issued Misc Letter 32 (6/02/14) to AT&T requesting their attention to this issue and a field meeting with Tutor to review issue.</p> <p>So as not to delay response while waiting for AT&T, SFMTA issued Letter 213 (6/9/14) to TPC. The NDSC was denied due to the fact that the utility drawings are schematic and not meant to depict all bends, sweeps, or joings in conduit.</p> <p>TPC forwarded an additional NDSC (TPC Letter 170) from their Subcontractor (Becho) on 6/5/14 regarding the delays in AT&T conduit coordination.</p> <p>SFMTA responded via Letter 215, denying Becho's claim of delay. TPC appears to have internal coordination issues which need to be resolved.</p> <p>The value inputted in the lump sum is a rough place holder.</p>	
00072	6/9/14	UMS NDSC #9 Becho Obstruct E Pile	DENI	Unforeseen Condition			\$8,000	<p>Tutor/Becho failed to prove that the reinforced concrete they encountered was unexpected or unforeseen. Becho (subcontractor) states that neither the geotechnical baseline nor the contract drawings show the reinforced concrete. SFTMA drawing ES-102 shows soldier beams and a bulkhead were to be demolished and removed.</p> <p>NDSC was denied via Letter 211.</p>	

Trend	Date	Title	Status	Reason	PCC	COR	Value	Remark	CMod No.
00073	6/9/14	UMS NDSC #10 Becho Obstruct E Pile	DENI	Unforeseen Condition			\$9,000	Tutor/Becho failed to prove that the reinforced concrete they encountered was unexpected or unforeseen. Becho (subcontractor) states that neither the geotechnical baseline nor the contract drawings show the reinforced concrete. SFTMA drawing ES-102 shows soldier beams and a bulkhead were to be demolished and removed.	
00074	6/11/14	UMS Powell St. Elevator Site Hazmat	DENI	Unforeseen Condition			\$15,900	<p>NDSC was denied via Letter 212.</p> <p>CMOD #1 Initiated the design for the elevator at the west end of Powell St. Station. Several cut sheets have been submitted to SFMTA, but none even approach the minimum threshold of what would be considered as a conceptual design as defined in the Specifications.</p> <p>This cost proposal was rejected via Letter No. 219. The proposal could not be evaluated since the conceptual design had not been submitted therefore it was impossible to contemplate the scope of the work and the full extent of the required abatement activities.</p> <p>Ultimately, this will have to be negotiated when the final conceptual design is approved and the scope of work established. None of the existing building materials were sampled or tested before the contract went out to bid.</p> <p>Tutor has issued a letter No. 177 (in response No. 219) stating that their conceptual design for the elevator is forthcoming.</p>	
00075	6/13/14	YBM FACO #24 Conflict new culvert	OPN	Errors and Omissions			\$5,000	Merit presented to CMB on 6/18/14 - Agreed for pothole only. Work completed on 6/24/14. Tutor has yet to submit bill. Change Order will be required.	
00076	6/13/14	Additional manholes for 78" sewer	NEW	Private Utilities			\$0	SFPUC requested 11 additional manholes to be included with the 78" sewer design. Per Manfred Wong's 6/12/14 email, SFPUC will pay for the additional manholes. ROM: \$5k/manhole for 11 manholes = \$55,000. Eng. estimate forthcoming.	
00077	6/13/14	Relocation of Comm & Elec Cabinets	NEW	Errors and Omissions			\$0	Original location on Freelon, east of 4th Street does not meet DPW-BSM sidewalk space requirement. New location is Brannan, east of 4th Street. This was present to CMB on Sept. 4, 2013. Engineer estimated for \$6607.	
00078	7/8/14	YBM-FACO #28 concrete obst 20" cut	NEW	Unforeseen Condition			\$0	Merit presented to CMB on 7/9/14 - Agreed. Work to be tracked on Force Account and paid through Allowance Item 13. Work completed on 7/10/14. Tutor yet to submit bill.	
00079	7/8/14	YBM concrete overpour at end stop	NEW	Other			\$25,000	DSC issued on 6/25/14. Issue discussed with John on 7/7/14. SFMTA requested Tutor submit a COR on 7/8/14.	

Trend	Date	Title	Status	Reason	PCC	COR	Value	Remark	CMod No.
00080	7/18/14	UMS COR 12 Fire Hydrant @ OFarrell	NEW	Errors and Omissions		12	\$92,978	<p>January 27, 2014, RFI #269 was submitted and requested direction regarding the NE Corner of O'Farrell & Stockton, DWG PD-104 states to maintain and protect in place. They pointed out this in the middle of the exit #3 and #4 excavation, and appears to possibly conflict with the roof structure (drawing ST-355). Recommended this is removed and restored when the stairs are completed. CSDG Response: Fire hydrant and structural areaway do not appear to conflict with roof structure; refer to A/ST-522 and B/ST-522 for elevation of roof structure at this location. If necessary, pile location(s) may be adjusted to clear the 6" water line feeding the hydrant. Contractor may remove and replace the fire hydrant and structural areaway as an alternative to protect in place, provided that the Contractor obtains written approval of the SFFD. All work related to removal and replacement of the fire hydrant and structural areaway shall be at no additional cost to SFMTA.</p> <p>RE coordinated between SFFD and TPC regarding relocating the hydrant. SFMTA has maintained stance that hydrant relocation is a choice of the Contractor, that drawings state that it is to be maintained in-place.</p> <p>SFFD (B. Gunn) obtained SFFD approval for hydrant relocation to east end of O'Farrell on June 6, 2014. (Notification Via Email)</p> <p>TPC submitted Letter 195 on July 11, 2014 with COR #12. COR maintains that PD drawings are only applicable to pavement demolition work, and NOT to the excavation work. TPC asserts that SFMTA's designers did not coordinate the necessary fire hydrant relocation scope for the stair #3/#4 excavation and construction, as was done with the other work impacted fire hydrants shown on drawing UD-305 (notes 3 and 4 were not called out). Provided two prices. Relocate hydrant down street (part 1) and return hydrant back to original location at end of project (part 2).</p> <p>CM & CSDG are reviewing for merit.</p>	
00081	7/18/14	UMS FACO #25 OCS Pole@ Market/Ellis	NEW	Other			\$2,000	FACO #25 was issued to cover potholing to confirm alternate location. See other trend for additional background information.	
00082	7/18/14	UMS NDSC Conflict w/ Pipe @ OFarrell	DENI	Unforeseen Condition			\$7,500	<p>Contractor submitted letter 196 which makes reference to Valverde's (TPC's underground sub) attached letter. Valverde submits a Notice of DSC stating that during potholing investigation, two existing CI pipes 30" and 32" from finished surface were encountered in conflict with the alignment of the pile line. One line is encased in concrete. The Piles for the proposed station cannot be installed with the pipes in their current position. One pipe is encased in concrete. The request is to issue a FACO to confirm lines are inactive, break out concrete, cut and remove conflicting 6" CI pipes.</p> <p>Letter 258 was issued to tutor on 7/22/14. It denied the NDSC on the basis that the pipes in question were abandoned and abandoned utilities are not compensable.</p> <p>Cost listed is an estimated exposure.</p>	
00083	7/21/14	STS-COR #9 Re Haz Debris 78" Sewer	NEW	Unforeseen Condition			\$0	Debris in the 78" sewer along 4th between Brannan and King. Contractor unsuccessfully jet cleaned debris. Contractor considered this as unforeseen condition. Contractor provided COR #9 for amount of \$60,879.	

Trend	Date	Title	Status	Reason	PCC	COR	Value	Remark	CMod No.
00084	7/21/14	UMS Modification to Roof Composite	CLO	Other	002		\$0	<p>Description of PCC: At UMS roof, replace 3" high, 16 gauge composite deck with 2" high, 18 gauge composite deck; overall slab thickness remains 6 inches. Alternatively, at UMS roof, replace 7/8" x 3 1/2" high studs with 7/8" x 5" high studs; overall slab thickness remains 6 inches. Contractor to price both options. SFMTA will issue CMod based on the most cost-effective option. Location/Station: UMS Station Roof Level; from CTL Sta 128+91.11 to CTL Sta 135+77.825 and from ELL Sta 135+77.825 to ELL Sta 138+59.934.</p> <p>Cost proposal received on 6/4/14 from TPC via TPC Letter 163. Costs exceeded the engineer's estimate, and proposal was sent to CSP estimator for review.</p> <p>Costs were not reconciled as of 6/18/14 (despite TPC having PCC for 6 months), and TPC expressed urgency that direction was needed. SFTMA issued letter 225 directing TPC to proceed with Option 'B', and that costs would be negotiated.</p> <p>Negotiation between RE and TPC ongoing.</p>	
00085	7/22/14	YBM Delete Bid Item BI-4 and BI-31	CLO	Other			(\$1,910,000)	Delete comp grout at YBM.	
00086	7/24/14	UMS NDSC 8" Water Main Connection	NEW	Unforeseen Condition			\$45,000	<p>Contractor maintains that they incurred additional potholing to find end cap for 8" main shown on WD-308. Also request delta cost to cover installing the (approx) 78'-0" of additional 8" pipe line.</p> <p>Under review. Costs are place holder based on previous waterline estimates submitted by Valverde.</p>	
							Total:	\$4,439,350	

CENTRAL SUBWAY PROJECT
Project Trend/Change Control Log

rent Cost Estimate and Allocated Contingencies									
Item #	Change Description	Change Type	CMB No.	Change Status		Projected Cost Impact +Exposure/(Benefit)	Comments	Contract Modification Number	
				Approval Action	Approval Date				Actual/Forecast
Contract 1250 - Utilities Relocation #1 (Portal & MOS)									
1250-0001	081-0001	Delete Option MF-OPT1 "Fire Protection Sprinkler System"	1	N/A			(50,000)	Cleared City Attorney's Office; to Shahnam for execution. [In "Current Forecast" - Sep2010 Cost Report.] COMPLETE, NO FURTHER ACTION; CMOD #1	CMOD #1 Approved
1250-0002	081-0002	Changes to Sewer on 4th between Howard and Folsom	2	CMB-0001	Agree	07/12/10	+107,174	Differing conditions as AWSS is directly over existing sewer; unable to install sewer manhole per plan. [In "Current Forecast" - Sep2010 Cost Report.] No reimbursement from SFPUC Sewer. COR #2-\$34,135; COR #5-\$73,039 COMPLETE, NO FURTHER ACTION; CMOD #2	CMOD #2 Approved
1250-0003	081-0003	Quantity Adjustment for JT-6 and JT-7	4	CMB-0002	Agree	08/04/10	+192,420	In April 2010 pay app. JT-6 bid qty exceeded by 344% (230 vs. 1021) and JT-7 bid qty exceeded by 112% (500 vs. 1060) [In "Current Forecast" - Sep2010 Cost Report.] COMPLETE, NO FURTHER ACTION; CMOD #3	CMOD #3 Approved
1250-0004	081-0004	Demolition of existing brick and concrete footing on 4th between Howard and Folsom	2	CMB-0003	Agree	07/12/10	+170,000	Unforeseen bricks and concrete footing discovered on east side of 4th Street between Folsom and Howard. [In "Current Forecast" - Sep2010 Cost Report.] COR #3-RFI #76 COMPLETE, NO FURTHER ACTION; CMOD #4	CMOD #4 Approved
1250-0005	081-0005	Modify AWSS at 4th/Bryant and 4th/Harrison	3	CMB-0004	Agree	08/04/10	+586,000	At 4th/Bryant, AWSS conflict with new 48" sewer and AT&T duct bank. At 4th/Harrison, AWSS conflict with 18" sewer. [In "Current Forecast" - Sep2010 Cost Report.] No reimbursement from SFPUC AWSS. PCC #2: RFI #s 34, 49 & 51 COMPLETE, NO FURTHER ACTION; CMOD #5	CMOD #5 Approved
1250-0006	081-0006	Install four additional piles and reinforce existing foundation at 401 4th Street	2	CMB-0005	Agree	08/25/10	+130,000	Existing foundation was discovered to be part brick and part concrete, which is different from plan. Also, foundation was unstable and required additional reinforcement. Refer to RFIs #85R1, 88.1, 100, 101, 102 COMPLETE, NO FURTHER ACTION; CMOD #6	CMOD #6 Approved
1250-0007	081-0007	Additional work to install 48" sewer due to various utility conflicts at 4th/Bryant	2	N/A			+32,964	48" RCP sewer in conflict with existing AT&T duct bank that needs to remain in service until new joint trench is installed to enable switchover. This conflict forced contractor into a more expensive means to install sewer. Also, 48" RCP sewer in conflict with existing 30" force main and 24" steel pipes. No reimbursement from SFPUC Sewer. COMPLETE, NO FURTHER ACTION; CMOD #9	CMOD #9 Approved
1250-0008	081-0008	Relocate TPC vault on 4th Street between Howard and Folsom	6	N/A			+19,500	Contractor uncovered existing TPC conduits on top of AT&T duct bank on 4th near Howard, a differing site condition. An AT&T intercept vault is to be installed, however, TPC conduits can not reside inside AT&T intercept vault. Joint Trench utilities participation cost TBD. Executed on 10/14/2010. Refer to RFI #62 (\$19,500) Expected Reimbursement from TPC. RE has provided documentation of notification to TPC, July-August '10. See final 1250 Form B actual costs COMPLETE, NO FURTHER ACTION; CMOD #8	CMOD #8 Approved

- 1 - Owner Directed Change in Scope
- 2 - Unforeseen Conditions
- 3 - Errors and Omissions
- 4 - Quantity Variation
- 5 - Value Engineering
- 6 - Private Utilities
- 7 - Other

CENTRAL SUBWAY PROJECT
Project Trend/Change Control Log

Item #	Change Description	Change Type	CMB No.	Change Status		Projected Cost Impact +Exposure/(Benefit)	Comments	Contract Modification Number	
				Approval Action	Approval Date	Actual/Forecast			
1250-0009	081-0009	Install additional sewer and provide temporary connections at 4th/Stillman	3	N/A			+47,000	Location of existing sewer to be intercepted differs from where it's shown in the plan, hence additional sewer to be installed. Also, due to optional sewer MH not buildable until (E) AT&T DB is removed, additional sewer is necessary to tie into (E) main as interim. New sewer is supposed to tie into optional MH. No reimbursement from SFPUC Sewer. RFI #91 COMPLETE, NO FURTHER ACTION; CMOD #7	CMOD #7 Approved
1250-0010	081-0010	Perform AT&T wye cast connection and chipping of existing duct bank at various locations	6	N/A			+48,181	AT&T was supposed to tie-in its own facility. However, AT&T's contractor, who is hired to install vaults, stated it is not in their scope of work. Refer to RFI #82.1. AT&T intercept vault at 4th/Harrison can not be installed at design location due to utility conflicts. AT&T vault to be shifted a few feet instead of vault being on top of existing duct bank. This will cause additional excavation, joint trench and modification to existing duct bank. Joint Trench utilities participation cost TBD. SFMTA and AT&T are negotiating with Contractor. (\$48,181) Expected Reimbursement from AT&T. RE has provided documentation of notification to AT&T, Sept-Oct '10. See final 1250 Form B actual costs. COMPLETE, NO FURTHER ACTION; CMOD #10	CMOD #10 Approved
1250-0011	081-0011	Remove existing piles and shoring at 801 Howard	2				-0-	This change order has been incorporated in CMOD #16 (Trend #30) COMPLETE, NO FURTHER ACTION; CMOD #16	CMOD #16 Approved
1250-0012	081-0012	Additional work related to AT&T facilities due to unforeseen conditions.	6	CMB-0047	Agree	08/03/11	-0-	This is the total of all force account work related to AT&T facility. SFMTA to seek reimbursement from AT&T through the Form B process. (\$67,798) Expected Reimbursement from AT&T. Cost captured in Trend #15 COMPLETE, NO FURTHER ACTION; CMOD #20	CMOD #20 Approved
1250-0013	081-0013	Additional work related to PG&E facilities due to unforeseen conditions.	6	CMB-0047	Agree	08/03/11	-0-	This is the total of all force account work related to PG&E facility. SFMTA to seek reimbursement from PG&E through the Form B process. (\$30,547) Expected Reimbursement from AT&T. Cost captured in Trend #15 COMPLETE, NO FURTHER ACTION; CMOD #20	CMOD #20 Approved
1250-0014	081-0014	Remove brick wall at sewer sta 152+94 (west side) on 4th between Howard and Folsom.	2				-0-	This change order has been incorporated in CMOD #16 (Trend #30) COMPLETE, NO FURTHER ACTION; CMOD #16	CMOD #16 Approved
1250-0015	081-0015	Archaeological Findings - Charges for rental of steel plates, triton barriers, shoring and labor for maintenance.	2				+784,771	Midden deposits were discovered on 4th Street between Howard and Folsom. Contractor stopped work. Contractor requesting payment for rental charges of trench plates, barricades, and shoring, and cost of maintenance. Total cost exposure is projected through end of November 2010. The \$290,703.00 is expected to be the final estimate for the rental of trench plates, barriers and shoring. \$597,000 Arch, \$179, 000 DIFF. \$8,500 Traffic COMPLETE, NO FURTHER ACTION; CMOD #20	CMOD #20
1250-0016	081-0016	Additional AWSS modification at 4th/Harrison	1	CMB-0016	Agree	11/10/10	+156,418	New alignment is proposed by Design team. No reimbursement from SFPUC AWSS. COR #33 Supplemental COMPLETE, NO FURTHER ACTION; CMOD #12	CMOD #12 Approved
1250-0017	081-0017	Protection Work at PG&E Vault 1611	6				-0-	Expected Reimbursement from PG&E or work to be deferred \$6,400. RE has notified PG&E via email dated 10/29/10 that SFMTA expects full reimbursement for this work if implemented. Follow-up pending. Work was not performed and will need to be addressed in a future contract.	
1250-0018	081-0018	Demolition and Support Work at PG&E Vault 1611	6				-0-	Expected Reimbursement from PG&E or work to be deferred \$25,000. RE has notified PG&E via email dated 10/29/10 that SFMTA expects full reimbursement for this work if implemented. Follow-up pending. Work was not performed and will need to be addressed in a future contract.	
1250-0019	081-0019	Extended overhead delay claim due to Archaeological discoveries	2					Old Note: Potential delay claim if issue extends project duration. Amount is estimated at \$3,000.00 per day for 60 days (\$180K). New Note: By exercising all option work, additional 84 calendar days is added to the contract time. In addition, midden mitigation will start on 10/7/10. As a result, the potential for extended overhead cost is averted. This trend has been superseded by Trend #37. COMPLETE, NO FURTHER ACTION	

- 1 - Owner Directed Change in Scope
- 2 - Unforeseen Conditions
- 3 - Errors and Omissions
- 4 - Quantity Variation
- 5 - Value Engineering
- 6 - Private Utilities
- 7 - Other

CENTRAL SUBWAY PROJECT
Project Trend/Change Control Log

Item #	Change Description	Change Type	CMB No.	Change Status		Projected Cost Impact +Exposure/(Benefit)	Comments	Contract Modification Number	
				Approval Action	Approval Date	Actual/Forecast			
1250-0020	081-0020	Sewer modification under I-80 freeway at 2 locations	3			+39,062	Inverts of existing sewer where new sewer will tie into are found to be different than shown in plan and would create a reverse slope. Additional pipe and manhole are required to fix slope. Refer to RFI Nos. 2S01 and 147. No reimbursement from SFPUC Sewer. COMPLETE, NO FURTHER ACTION; CMOD #11	CMOD #11 Approved	
1250-0021	081-0021	Install new AWSS lateral including hydrant at NW 4th/Harrison	2				Existing AWSS lateral at SW 4th/Harrison is in conflict with new 18" sewer. Instead of modifying the lateral to avoid the sewer, a new lateral at NW corner is a preferred solution. CM awaiting design revision from Design team. Trend No. 21 is combined with Trend No. 22.		
1250-0022	081-0022	Install additional 30 feet of DIP and new AWSS at 4th/Harrison	2	CMB-0026	Agree	01/12/11	+160,908	AWSS Point of connection on 4th Street was found to be cast iron instead of ductile iron as shown in DPW as-built. Due to this differing condition, additional length of pipe needs to be replaced and lead joint to be installed in order to install a ductile iron tee. Also, existing AWSS hydrant lateral is in conflict with new 18" sewer. The preferred solution was to install a new ductile iron lateral at a different location rather than installing vertical offsets on an existing cast iron lateral. No reimbursement from SFPUC AWSS. COMPLETE, NO FURTHER ACTION; CMOD #15	CMOD #15 Approved
1250-0023	081-0023	Steel plates and shoring standby for 2 months due to PG&E delay at Clementina	3			+24,981	Sewer at Clementina was delayed by 2 months due to PG&E vault conflict. PG&E will not pay cost of steel plates and shoring standby because PG&E drawings were sent to MTA during design phase and PG&E was not made aware of the conflict then. COMPLETE, NO FURTHER ACTION; CMOD #13	CMOD #13 Approved	
1250-0024	081-0024	Utility support and work around for AT&T facilities	6	CMB-0048	Agree	08/24/11	+95,311	Contract specs specified AT&T to compensate contractor directly for workaroud & support. AT&T refused to pay Synergy. Synergy considers AT&T's refusal as a changed condition to CN 1250 contract. (\$95,311) Reimbursement from AT&T. See Final 1250 Form B actual costs. COMPLETE, NO FURTHER ACTION; CMOD #19	CMOD #19 Approved
1250-0025	081-0025	Utility support and work around for PG&E facilities	6				Contract specs specified PG&E to compensate contractor directly for workaroud & support. PG&E negotiated \$100,000 directly with Synergy and will pay synergy directly as well.		
1250-0026	081-0026	Utility support and work around for SFWD facilities	3	CMB-0028	Agree	02/09/11	+66,510	Total cost known to date (10/5/10) of all SFWD support and workaroud. See COR #12, 20, 32 and 35. Agreed amount is total of COR #12, 20 and 32. Total exposure is equal to agreed amount plus COR #35. No reimbursement from SFWD. COMPLETE, NO FURTHER ACTION; CMOD #14	CMOD #20 Approved
1250-0027	081-0027	Trucking and labor support for Archaeological mitigation	2				Synergy is asked to provide trucking for delivery of midden soil to Sonoma State University lab. Other support work includes traffic control, plating, loading and unloading of midden soil. The amount shown are charges up to end of November 2010 only. Additional charges are expected which will be tracked as Trend No. 28. COMPLETE, NO FURTHER ACTION	CMOD #20 Approved	
1250-0028	081-0028	Trucking and labor support for Archaeological mitigation, Part II	2				Synergy is asked to provide trucking for delivery of midden soil to Sonoma State University lab. Other support work includes traffic control, plating, loading and unloading of midden soil. The amount shown are expected charges beyond November 2010. COMPLETE, NO FURTHER ACTION	CMOD #14 Approved	
1250-0029	081-0029	Cost overrun for bid item UD-10 "Additional excavation and backfill"	4	CMB-0036	Agree	05/04/11	+112,500	Bid item UD-10 is to pay for excavation of connection hole and kill hole for SFWD line. Contract only included 200 cubic yard for this work. The size of excavations is dictated by field conditions and per the direction of SFWD inspector. RE's estimate of the total volume of dirt to be excavated is 630 cy. Examples of differing conditions encountered are: location of existing water line is different than where it's shown in the plan, existing waterline where shown in the plan to be connected to is inactive, differing condition at 5th/Clementina, connection holes and kill holes need to be expanded due to other utilities in the way. COMPLETE, NO FURTHER ACTION; CMOD #17	CMOD #17 Approved

- 1 - Owner Directed Change in Scope
- 2 - Unforeseen Conditions
- 3 - Errors and Omissions
- 4 - Quantity Variation
- 5 - Value Engineering
- 6 - Private Utilities
- 7 - Other

CENTRAL SUBWAY PROJECT
Project Trend/Change Control Log

Item #	Change Description	Change Type	CMB No.	Change Status		Projected Cost Impact +Exposure/(Benefit)	Comments	Contract Modification Number	
				Approval Action	Approval Date	Actual/Forecast			
1250-0030	081-0030	Supplement bid item GE-4 "Allowance for differing site conditions" related to the installation of publicly owned facilities only (sewer, water, AWSS, Joint trench)	4	CMB-0030	Agree	04/13/11	+235,595	This change order is to supplement GE-4 for cost overrun related to the installation of publicly owned infrastructure only. GE-4 cost overrun for installation of privately owned infrastructure is being tracked separately and a separate change order will be issued. COMPLETE, NO FURTHER ACTION; CMOD #16	CMOD #16 Approved
1250-0031	081-0031	Unused allowance for bid item GE-8 "Allowance for cast-in-place utility vaults"	4				-0-	Bid item GE-8 is an allowance to pay contractor for designing and constructing cast-in-place manholes as required for installation of new systems. Only one CIP vault was installed. Credit amount included in Trend #43	
1250-0032	081-0032	Unused allowance for bid item UD-5 "Handling and disposal of Class I Hazardous Waste"	4				-0-	Bid item UD-5 is an allowance to pay contractor for handling and disposal of Class I Hazardous Waste. No class I hazardous waste was off hauled away from the job site. Class I soil found under the I-80 freeway was put back in the trench as backfill. This bid item is expected to remain unused. However, contractor is claiming to recover "General Conditions" cost. Credit amount included in Trend #43	
1250-0033	081-0033	Unused allowance for bid item UD-6 "Transportation of Class I Hazardous Waste"	4				-0-	Bid item UD-6 is an allowance to pay contractor for transporting of Class I Hazardous Waste. No class I hazardous waste was off hauled away from the job site. Class I soil found under the I-80 freeway was put back in the trench as backfill. This bid item is expected to remain unused. However, contractor is claiming to recover "General Conditions" cost. Credit amount included in Trend #43	
1250-0034	081-0034	Cost overrun for bid item TR-6 "Allowance for manual traffic control"	4	CMB-0037	Agree	05/04/11	+68,820	Bid item TR-6 is an allowance to pay for off-duty police officers and parking control officers. Contract allowance amount is \$50,000.00. Contract specs calls for police officers at 4 intersections (4th/Howard, 4th/Folsom, 4th/Harrison and 4th/Bryant). The average cost of 1 police officer is about \$800.00 per day (\$100.00 per hour). The \$50,000.00 allowance is only good for 60 days for 1 police officer. Hence, additional money was needed for traffic control support. Final amount paid police officers is \$87,500.00. Additional billings for parking control officers (from Al Herce of DPT) is forthcoming; RE estimated this bill to be about \$60,000.00. COMPLETE, NO FURTHER ACTION; CMOD #18	CMOD #18 Approved
1250-0035	081-0035	Premium cost for requesting contractor to accelerate work on 4th Street between Howard and Folsom	2				-0-	Due to archaeological discoveries, many trenches remained open and the project would not have enough time to complete installation of underground utilities and restore the roadway before the Holiday season. Without accelerating the work, the project would have had to pay rentals for the barriers, street plates and shoring for the unfinished trenches that would have remained. By accelerating the work and DPT allowing the contractor to work through the beginning of the Holiday Moratorium, the project avoided these rental costs, which is estimated to be greater than the premium cost of accelerating the work. COR Not submitted by Contractor CLOSED COMPLETE, NO FURTHER ACTION	
1250-0036	081-0036	Rental/Maintenance costs for support of Archeological Trenches (Part 1 of 4) \$255,840; Support Work During Archeologist Mitigation Efforts (Part 2 of 4) \$199,741; Mobilization and Equipment Standby Costs (Part 3 of 4) \$67,728; Additional Overhead/Indirect Costs During Archeological Delay Period (Part 4 of 4) \$124,186	2	CMB-0041	Agree	07/13/11 02/15/12 07/25/12 09/12/12	-0-	Due to archaeological discoveries, contractor may potentially claim for compensation for his equipment that were idle for the duration of the waiting period. RE's estimate is based on Caltrans rate for equipment standby for 5 months (May to October). RE has not received any change order request related to this item. RE to verify if his equipment were indeed idle during this time period. 2/15: Rental/Maintenance Costs for Support (Part 2 of 4); Addl Work as Result of Archeological Shutdown (3 of 4). 07/25: Revised mod - compensation for 1 of 3) Rental/Maintenance, 2 of 3) Addl Work result of Archeological support, 3 of 3) Addl OH/Indirect cost. RE to add Equipment Standby time to revised mod. 09/12: RE to Prepare Modification 10/29: CMod 20 is being issued as a unilaterally change, by the SFMTA that represents the SFMTA's estimate of a fair and reasonable final compensation amount for the additional work. COMPLETE, NO FURTHER ACTION	CMOD #20 Approved

- 1 - Owner Directed Change in Scope
- 2 - Unforeseen Conditions
- 3 - Errors and Omissions
- 4 - Quantity Variation
- 5 - Value Engineering
- 6 - Private Utilities
- 7 - Other

CENTRAL SUBWAY PROJECT
Project Trend/Change Control Log

Item #	CMB No.	Change Description	Change Type	Change Status		Projected Cost Impact +Exposure/(Benefit)	Comments	Contract Modification Number
				Approval Action	Approval Date			
1250-0037	081-0037	Compensation for loss of production, inefficiency and disruption of work due to archaeological discovery	2			-0-	Due to archaeological discoveries, contractor may potentially claim for compensation for loss of production, inefficiency and disruption of work. RE has not received any change order request related to this item. Amount shown is a ROM cost by the RE. RE expects a COR from the contractor but change justification is very unlikely. Initial draft COR was \$898,453. RE has adjusted to \$661,559 removing the month of October and option work. This was then revised to 800,000. There has been no official submittal from Synergy. SFMTA has directed Synergy to submit anything related to the Architectural delays through the claims process. This will be carried in the Potential Claim Log. COMPLETE, NO FURTHER ACTION	
1250-0038	081-0038	Project Delay due to archaeological discovery and PG&E Issues.	2			-0-	Due to archaeological discoveries compounded with PG&E's ability to perform service switchover to Olivet University and de-energize a live duct bank in conflict with 48" sewer. The project will realize an estimated 6 weeks of non-compensable delay to the substantial completion date of 4/6/11. 47 days estimated by RE. Contractor submitted COR 51 in the amount of \$1,144,776.74 on September 1st, 2011. RE responded requesting additional backup on October 19th, 2011. Subsequently, no additional information has been provided by the contractor, therefore, SFMTA has directed Synergy to submit anything related to the Architectural delays through the claims process. This will be carried in the Potential Claim Log.	
1250-0039	081-0039	Remove BP-4 (Waterproofing) from Contract	4			-0-	Bid item was not used. Contractor requesting compensation to recover for General Conditions cost. Bid item amount total is \$40,000. NO FURTHER ACTION; Superseded by COR #58. (See 1250-0043 below)	N/A
1250-0040	081-0040	Delete SW-8 (24" Sewer) from Contract	4			-0-	Bid item was not used. Contractor requesting compensation to recover for General Conditions cost. Bid item amount total is \$73,117. NO FURTHER ACTION; Superseded by COR #58. (See 1250-0043 below)	N/A
1250-0041	081-0041	Delete UD-5 and UD-6 (Class I Off haul and Handling) from Contract	4			-0-	Bid items were not used. Contractor requesting compensation to recover for General Conditions cost. Bid items total amount is \$150,000. NO FURTHER ACTION; Superseded by COR #58. (See 1250-0043 below)	N/A
1250-0042	081-0042	Delete GE-6 (Hazmat) from Contract	4			-0-	Bid item was not used. Contractor requesting compensation to recover for General Conditions cost. Bid item amount total is \$100,000. NO FURTHER ACTION; Superseded by COR #58. (See 1250-0043 below)	N/A
1250-9001	081-9001	Utility Companies refusal to contribute to utility support costs and work-around. (Voided. Recorded individually in TR-0059-TR-0061.)	7					VOIDED
1250-0043	081-0043	Unit Rate Adjustment for Entire 1250 Bid Items	4			(333,904)	Pursuant to General Provision GP-11, COR is to adjust contract value to account for fix overhead costs for bid items not performed or where the bid item performed varied by 25%. COMPLETE, NO FURTHER ACTION; CMOD #20	CMOD #20 Approved
Contract 1250 Totals						+2,694,211	Total Changes to the Contract in the amount of \$2,694,211, represents a \$740,834 OVER RUN of the original allocated contingency of \$1,953,377. Changes that will be Utility Reimbursement credits through the Form B process in the amount of \$162,992 will offset some of this OVER RUN. Final Contract Closeout Total \$11,968,150 will be reduce by \$2,275,419 Utility Reimbursement credits for a Final Program cost of \$9,692,731 for CN 1250	

Contract 1251 - Utilities Relocation #2 (UMS)

- 1 - Owner Directed Change in Scope
- 2 - Unforeseen Conditions
- 3 - Errors and Omissions
- 4 - Quantity Variation
- 5 - Value Engineering
- 6 - Private Utilities
- 7 - Other

CENTRAL SUBWAY PROJECT
Project Trend/Change Control Log

Item #	Change Description	Change Type	CMB No.	Change Status		Projected Cost Impact +Exposure/(Benefit)	Comments	Contract Modification Number	
				Approval Action	Approval Date	Actual/Forecast			
1251-0001	082-0001	Modify traffic control plan by establishing a single travel lane on Stockton St. in lieu of time-based multiple lane requirements as stipulated in contract plans TR-001 to 004.	7				After discussions with the Contractor and the Union Square Business Improvement District (BID), the SFMTA determined that modifying the lane requirements along Stockton St. and implementing the alternate pedestrian walkway design would be beneficial to the execution of CN 1251 in the following ways: increased public safety, increase construction production, and create a more pleasing environment to the public and merchant. COR #1 COMPLETE, NO FURTHER ACTION; CMOD #4	CMOD #4 Approved	
1251-0002	082-0002	Installation of reinforced concrete slab underneath Joint Trench along Stockton at O'Farrell (East Side). CTL 133+66.37 (27.08 LEFT) to CTL 134+00.87 (27.08 LEFT)	1&3	CMB-0035	Agree	04/20/11	+67,634	Pursuant to a commitment between Barney's and SFMTA, Emergency Stair #4 (to be constructed in CN 1253) must avoid existing subsidewalk basement. It was determined that moving the conflicting stairs would require the Joint Trench to be constructed in a manner that would enable it to span the excavated area. The addition of the invert slab allowed for the needed span thereby allowing for a relocation of Emergency Stair #4. COR #4; PCC #1 COMPLETE, NO FURTHER ACTION; CMOD #2	CMOD #2 Approved
1251-0003	082-0003	Adjust placement of 3EA manholes along Geary Street and O'Farrell Street. The modified manhole locations require the installation of approximately 265LF of additional HDPE pipe inside the existing 3'x5' brick sewer.	1	CMB-0029	Agree	02/23/11	+148,919	During future station construction, the design team anticipates that excavation related settlement may cause damage to the brick sewers along Geary and O'Farrell Streets. This proposed modification will replace the vulnerable brick sewer within the influence zone with HDPE pipe that will not be as susceptible to settlement-induced damage. COR #9, PCC #2 COMPLETE, NO FURTHER ACTION; CMOD #1	CMOD #1 Approved
1251-0004	082-0004	Changes to Neiman Marcus secondary enclosure wall due to various differing site conditions.	2	CMB-0031	Agree	04/13/11	+189,584	Due to various differing site conditions as described in RFIs 15, 37, 38 and 44, changes to the secondary enclosure wall are required. The existing footing were found to be inconsistent, i.e. missing footing in one area, footing sticks out beyond existing wall, overpour on existing footing, existing wall to be 6" into private property. Contract plan SR-302 shows a consistent footing. COR #8 COMPLETE, NO FURTHER ACTION; CMOD #3	CMOD #3 Approved
1251-0005	082-0005	Existing PG&E conduits were found on top and parallel to existing AWSS on Geary Blvd. at 2 locations (east and west of Stockton)	6				+66,084	Contract plans AW-501.1, 501.2, 501.4 and 501.4 show the existing AWSS to be replaced in place. However, existing PG&E conduits were found to be on top and parallel to the existing AWSS resulting in extra work in working around and/or shifting the existing electrical conduits. Contract plans JT-308 and 309 showed the existing electrical and AWSS to be separate. Estimate includes \$77,892.53 (Synergy FA Request) + \$25,000 (first digging west side) + \$10,000 (temp backfill during moratorium) + \$15,000 (plate rental west side at \$5k per month). Estimate does not include Synergy's cost to sequence his work. Updated projected cost impact from \$50,000 to \$127,893 based on compilation of force accounts received. RE negotiating COMPLETE, NO FURTHER ACTION	CMOD #24 Approved
1251-0006	082-0006	Design changes to utilities on Stockton street between Post and Geary	1	CMB-0039	Agree	06/08/11	+398,624	Due to changes to the limits of the UMS Station on Stockton Street between Post and Geary, the original utility design has changed. COR #24, PCC #4 COMPLETE, NO FURTHER ACTION; CMOD #5	CMOD #5 Approved
1251-0007	082-0007	Design changes to utilities on Ellis Street	1	CMB-0049	Agree	08/24/11	(434,957)	Due to changes to the limits of the UMS Station on Ellis street, the original utility design has changed. PCC #5 COMPLETE, NO FURTHER ACTION; CMOD #5	CMOD #5 Approved
1251-0008	082-0008	Elimination of underpinning at 150 Stockton	1					Based on field verification, it was determined that underpinning is no longer needed. Contract bid item SR-9 is for a total amount of \$116,000 measured by LF. However, CM team does not anticipate to recover the full amount because contractor may be entitled to retain general conditions cost and some excavation cost that was already performed but encumbered in Bid Item SR-9. Agreed credit of (\$58,000) to be included in Trend #60. CLOSED, NO FURTHER ACTION	

- 1 - Owner Directed Change in Scope
- 2 - Unforeseen Conditions
- 3 - Errors and Omissions
- 4 - Quantity Variation
- 5 - Value Engineering
- 6 - Private Utilities
- 7 - Other

CENTRAL SUBWAY PROJECT
Project Trend/Change Control Log

Item #	Change Description	Change Type	CMB No.	Change Status		Projected Cost Impact +Exposure/(Benefit)	Comments	Contract Modification Number	
				Approval Action	Approval Date	Actual/Forecast			
1251-0009	082-0009	Additional cost for police officers and/or Parking Control Officers for traffic control.	4	CMB-0038	Agree	06/01/11	+261,584	Contract bid item TR-7 for manual traffic control in the amount of \$120,000 is insufficient to control traffic for the duration of the contract. The \$120,000 allowance only equates to one police officer for a duration of 7.5 months. At a minimum, it is anticipated that one police officer or PCO will be needed at Stockton/Post for the entire contract duration of 16 months. Additionally, one PCO is required for each intersection at Geary/Stockton and O'Farrell/Stockton. COMPLETE, NO FURTHER ACTION; CMOD #4	CMOD #4 Approved
1251-0010	082-0010	Accelerate Stockton east between O'Farrell and Market	1				+27,409	Contractor needed to rent additional excavators to work concurrently with the other block on Stockton between O'Farrell and Market. Amount: \$27,409; COR #25 COMPLETE, NO FURTHER ACTION; CMOD #3	CMOD #3 Approved
1251-0011	082-0011	Potholing at 4th/Howard for PUC sewer design	1					Request from MOS utility design team to pothole for the intercept of a 36" force main sewer and 96" sewer. PUC requested that this be done in order to ensure that we have accurate utility information to avoid costly change orders during construction. Per direction from CMB on January 18, 2012, this request is denied. COR #50, PCC #6 CLOSED, NO FURTHER ACTION: Per direction from CMB on January 18, 2012, this request is denied.	
1251-0012	082-0012	Additional cost to lower the AWSS at O'Farrell, east of Stockton, due to numerous existing utility conflicts.	2	CMB-0042, CMB-0050	Agree	8/3/2011, 9/21/2011	+278,351	The AWSS is in conflict with AT&T, PG&E and several other utilities and needs to be installed under all these utilities at about 11' deep (instead of 6' depth as noted in Plan AW-501.4, sheet note #5). During negotiations with the Contractor several items of work were found to be missing for the original cost estimates which increase the amount to \$278,351. RFI #76, COR #31 COMPLETE, NO FURTHER ACTION; CMOD #6	CMOD #6 Approved
1251-0013	082-0013	Accelerate start of construction in front of Macys West by trenchless construction method	7				-0-	Micropile installation on Stockton east between O'Farrell and Market has proven to be much slower than anticipated. To mitigate this potential delay, contractor requested to start construction in front of Macys West. COR 32 (CMB 0055 approval - see also Trend CN1251 #'s 04 & 10) COMPLETE, NO FURTHER ACTION; CMOD #3 (No Cost Change)	CMOD #3 Approved
1251-0014	082-0014	Increase in Bid Item WD-10, Allowance for Additional Excavation and Backfill.	3	CMB-0055	Agree	09/14/11	+191,779	This allowance is for the contractor to perform additional excavation, backfilling and restoration associated with the water tie-ins and capping for the distribution piping system. The contractor has performed two water service tie-ins at an average cost of \$14,000 per tie-in. The current number of tie-ins and capping is 35 separate points. This amounts to a total cost of \$490,000. The current contract allowance amount is \$100,000, therefore an additional \$390,000 will be needed to augment is bid item. CMB made a partial approve of up to \$200K. The initial Contract Modification to supplement this allowance is in the amount of \$191,778.62. RE's cost analysis of this trend confirms that the initial CMod amount of \$191,778.62 is sufficient to cover for all water tie-in/capping work. COMPLETE, NO FURTHER ACTION; CMOD #9	CMOD #9 Approved
1251-0015	082-0015	Additional traffic signal work at Post/Stockton	1				+17,530	Modification of the traffic signal at Post/Stockton is required to implement the detour shown in contract plan TR-010. There are no bid item to bill this work. COR #19 COMPLETE, NO FURTHER ACTION; CMOD #8	CMOD #8 Approved
1251-0016	082-0016	Additional traffic signal work at Sutter/Mason	2				+32,054	Existing conduits shown in Plan ET-101 differs from what is actually in the field. City's response to RFI 73 directs contractor to install new conduits and conductors. RFI #73; COR #33 COMPLETE, NO FURTHER ACTION; CMOD #8	CMOD #8 Approved
1251-0017	082-0017	Furnish and install AT&T Manhole 5830 on O'Farrell Street	6	CMB-0051	Agree	09/21/11	+25,000	AT&T was supposed to hire its own subcontractor to furnish and install all AT&T vaults in CN 1251. AT&T requested SFMTA for Synergy to perform this work as change order to CN 1251. AT&T agreed to reimburse SFMTA (\$25,000) through the Form B process. COMPLETE, NO FURTHER ACTION; CMOD #7	CMOD #7 Approved

- 1 - Owner Directed Change in Scope
- 2 - Unforeseen Conditions
- 3 - Errors and Omissions
- 4 - Quantity Variation
- 5 - Value Engineering
- 6 - Private Utilities
- 7 - Other

CENTRAL SUBWAY PROJECT
Project Trend/Change Control Log

Item #	Change Description	Change Type	CMB No.	Change Status		Projected Cost Impact +Exposure/(Benefit)	Comments	Contract Modification Number	
				Approval Action	Approval Date	Actual/Forecast			
1251-0018	082-0018	Furnish and install AT&T Manhole 5829 on Geary Blvd.	6	CMB-0051	Agree	09/21/11	+31,000	AT&T was supposed to hire its own subcontractor to furnish and install all AT&T vaults in CN 1251. AT&T requested SFMTA for Synergy to perform this work as change order to CN 1251. AT&T agreed to reimburse SFMTA (\$31,000) through the Form B process. COMPLETE, NO FURTHER ACTION; CMOD #7	CMOD #7 Approved
1251-0019	082-0019	Extend joint trench and modify existing AT&T Manhole 403 on Ellis Street.	6	CMB-0057	Agree	10/26/11	+31,000	AT&T was supposed to furnish and install AT&T vault #5833 on Ellis Street. The current design was to intercept the existing AT&T conduit in the middle of Ellis Street. It was discovered that the existing AT&T conduit actually run adjacent to the southern curb line along Ellis Street. Therefore, AT&T requested SFMTA for Synergy to extend the joint trench approximately 200 feet to the West and tie into their existing AT&T vault #403. This work will also require Synergy to enlarge vault #403 to accept the additional conduit. . This additional work for AT&T will need to be reimbursed to SFMTA through the Form B process. Note: The agreed amount (\$31,000) is for enlargement of vault #403 only; the additional 200 feet of trench to be captured in the JT bid items. (See Trend 60) COR #43 COMPLETE, NO FURTHER ACTION; CMOD #11	CMOD #11 Approved
1251-0020	082-0020	Change PG&E conduit material from PVC to GRS on west side of Stockton between Geary and Post	6	CMB-0058	Agree	11/02/11	+19,537	PG&E requested to use GRS material in lieu of PVC in areas where PG&E conduits were expected to be exposed and temporary supported during future UMS station construction. PG&E agreed to reimburse SFMTA (\$19,537) through the Form B process. COMPLETE, NO FURTHER ACTION; CMOD #21	CMOD #21 Approved
1251-0021	082-0021	Revise PG&E service points and layout of primary lines at various locations, and delete Muni Vault 1850 A at Stockton/Ellis.	6					PG&E made changes to the locations of the service points and layout of some of the primary lines. In addition, due to changes to the limits of the UMS Station on Ellis Street, it was determined that Muni Vault 1850A is no longer needed. Cost for this trend in captured in Trend #31 or CMod #12. CLOSED; NO FURTHER ACTION. Cost for this trend is captured in Trend #31/CMod #12	
1251-0022	082-0022	Change OCS supports at SF Hilton Hotel on Mason Street from embedded eyebolts to poles w/foundations.	7					During the design phase the representatives of the Hilton Hotel agreed to and signed a license agreement with the SFMTA to allow embedded eyebolt supports. Hilton's Dir of Property Ops now wants to have OCS poles rather than the embedded building eyebolt supports. However, the OCS designer was able to revise the OCS design to eliminate the need for either eyebolts or poles in front of Hilton Hotel, resulting in a \$2,000 credit. CLOSED; NO FURTHER ACTION. Applicable bid items to be adjusted accordingly, See Trend #60.	
1251-0023	082-0023	4th Street & Folsom Trolley Bypass	1	CMB-0065	Agree	1/25/2012, 2/29/12	+405,440	SFMTA Operations has requested a bypass be installed at 4th Street and Folsom Street. \$242,619 in labor costs for OCS installation has not been negotiated yet. 1/25: Condition agreed upon verification material from Contractor to be procured is available. (Verified 02/01/12). 02/29: CMod negotiated cost has been revised to incorporate original three items and the add'l OCS work on Folsom St. COR #52; PCC #7 Updated projected cost impact from \$490,000 to \$405,440. CMod #12 (Formally CMod #15) COMPLETE, NO FURTHER ACTION; CMOD #12	CMOD #12 Approved
1251-0024	082-0024	Install a 5" slurry wall between the gas line and wet utilities if the separation is less than 3 feet	6	CMB-0059	Agree	11/16/2011, 05/02/12	+201,411	As a new requirement, PG&E had requested that a 5" slurry wall be installed between the gas line and wet utilities where the separation between the 2 utilities is less than 3 feet. PG&E agreed to reimburse SFMTA (\$201,410) through the Form B process. COR #58 COMPLETE, NO FURTHER ACTION; CMOD #19	CMOD #19 Approved
1251-0025	082-0025	Additional PG&E conduit crossings at Geary and O'Farrell to minimize service interruption during future UMS Station construction	6					PG&E requested to install additional conduits crossing Stockton Street at Geary and O'Farrell to minimize service interruption during future UMS Station construction. PG&E agreed to reimburse SFMTA through the Form B process. This item is captured under applicable JT Bid item, see Trend 60. CLOSED; NO FURTHER ACTION. Item is captured under applicable JT Bid Item, See Trend 60.	

- 1 - Owner Directed Change in Scope
- 2 - Unforeseen Conditions
- 3 - Errors and Omissions
- 4 - Quantity Variation
- 5 - Value Engineering
- 6 - Private Utilities
- 7 - Other

CENTRAL SUBWAY PROJECT
Project Trend/Change Control Log

Item #	Change Description	Change Type	CMB No.	Change Status		Projected Cost Impact +Exposure/(Benefit)	Comments	Contract Modification Number	
				Approval Action	Approval Date	Actual/Forecast			
1251-0026	082-0026	Install cantilever footing in lieu of regular OCS foundation at 2 locations on Mason Street between Geary and O'Farrell	2				The sub-basement in the public parking garage at O'Farrell/Mason extends beyond the property line up to the curb line. Therefore, regular foundations as per original design could not be installed. CLOSED; NO FURTHER ACTION. Item is captured under applicable OCS Bid Item, See Trend 60.		
1251-0027	082-0027	Accelerate installation of AT&T facilities in order for AT&T to start cut-over sooner	1	CMB-0056	Agree	11/30/11	+281,435	Acceleration is necessary to avoid potential delay impacts to Central Subway follow-on contracts. COR #40 COMPLETE, NO FURTHER ACTION; CMOD #10	CMOD #10 Approved
1251-0028	082-0028	Furnish and install AT&T Manholes 5828 (Stockton), 5831 (Geary), 5832 (O'Farrell) and 113 (O'Farrell)	6	CMB-0057	Agree	10/26/11	+157,000	AT&T was supposed to hire its own subcontractor to furnish and install all AT&T vaults in CN 1251. AT&T requested SFMTA for Synergy to perform this work as change order to CN 1251. AT&T agreed to reimburse SFMTA (\$157,000) through the Form B process. COR #43 COMPLETE, NO FURTHER ACTION; CMOD #11	CMOD #11 Approved
1251-0029	082-0029	Rebuild existing AT&T vault 133 at Post/Stockton and demolish existing AT&T vaults 403 (Ellis) and 113 (O'Farrell)	6				Vault 133 rebuild is superseded by Trend 40. Demolition of existing vaults 403 and 113 is superseded by Trend 43 CLOSED; NO FURTHER ACTION. Demo of exiting vaults 403 and 113 are superseded by Trend 43. (See CMOD #23)		
1251-0030	082-0030	Enlarge existing PG&E vault 873 at SW Geary/Stockton	6	CMB-0058	Agree	11/02/11	+46,366	PG&E asked SFMTA to enlarge vault 873. PG&E agreed to reimburse SFMTA (\$46,366) through the Form B process. CMB approved a NTE amount of \$40K COMPLETE, NO FURTHER ACTION; CMOD #21	CMOD #21 Approved
1251-0031	082-0031	Additional PG&E conduits crossing O'Farrell on east side of Stockton (Task Order #32)	6	CMB-0058	Agree	11/02/11	+17,193	PG&E asked SFMTA to install additional conduits. PG&E agreed to reimburse SFMTA (\$17,193) through the Form B process. COMPLETE, NO FURTHER ACTION; CMOD #21	CMOD #21 Approved
1251-0032	082-0032	Excavation and restoration cost for PG&E gas tie-in and kill holes.	6	CMB-0059	Agree	11/16/2011, 05/02/12	+92,292	PG&E gas drawings were not included in the bid package and there was no bid item to capture this work. Gas drawings was issued by PG&E in June 2011. PG&E agreed to reimburse SFMTA (\$92,292) through the Form B process. Updated projected cost impact from \$202,400 to \$169,087 due to reduction in number of kill holes from 18 to 15. 04/11: Discovery of actual number of Kill/Tie locations being 26 instead of 15 will require confirmation from PG&E of the locations and the new cost of scope of work. COMPLETE, NO FURTHER ACTION; CMOD #19	CMOD #19 Approved
1251-0033	082-0033	Install secondary enclosure wall at One Stockton (Apple Store)	1	CMB-0068	Agree	03/07/12	+408,700	Additional enclosure wall is design initiated change. COR #47, PCC #9 Updated projected cost impact from \$262,484 to \$408,700. 39 Calendar Day Time Extension COMPLETE, NO FURTHER ACTION; CMOD #13 (formally CMOD #14)	CMOD #13 Approved
1251-0034	082-0034	Install temporary support as required to protect existing live utilities that are encroaching into the City right-of-way in front of 17-25 Stockton Street.	2	CMB-0069	Agree	04/04/12	+337,548	Existing utilities that are in active service were discovered in the City public right-of-way and are obstructing the performance of Contract work. Worst case scenario - "Not to Exceed" value) CM team will report actual amount value at a later date COR #71 CMB agreed to a Not-to-Exceed amount of \$346,456 on 4/4/12. All physical work was scheduled to complete by 4/13/12 COMPLETE, NO FURTHER ACTION; CMOD #17	CMOD #17 Approved
1251-0035	082-0035	Potholing on Stockton between Post and Geary for UMS Station design	1				UMS Design Team requested 1251 to pothole (6'Wx12'Lx8'D) on Stockton between Post and Geary to locate existing piles and tie-backs at Union Square. Cost for this scope of work from the Contractor is \$19,870.73. Per direction from the CMB on Jan 18th this request is denied and the DP2 designer will cover this potential future obstruction with a note on the drawings. COR #53 CLOSED; NO FURTHER ACTION. Per direction of CMB on 1/18/12, this request is denied and DP2 Designer will cover this potential future obstruction with a note on the drawings.		

- 1 - Owner Directed Change in Scope
- 2 - Unforeseen Conditions
- 3 - Errors and Omissions
- 4 - Quantity Variation
- 5 - Value Engineering
- 6 - Private Utilities
- 7 - Other

CENTRAL SUBWAY PROJECT
Project Trend/Change Control Log

Item #	Change Description	Change Type	CMB No.	Change Status		Projected Cost Impact +Exposure/(Benefit)	Comments	Contract Modification Number	
				Approval Action	Approval Date	Actual/Forecast			
1251-0036	082-0036	Install three 6" PG&E conduits from vault 5800 to PG&E "A" pullbox at 4th/Bryant.	6				CN 1252 Contract is requesting 1251 to install PG&E conduits in order to bring power in advance of the tunnel equipment arrival. The scope of work, which involves trenching at the busy 4th/Bryant intersection, was part of the 1252 contract, hence, a credit of same amount (\$54,892.07) to be due back to 1252. Based upon a field meeting and discussions with BIH on Jan 17th this work will be done under CN 1252 as originally planned. COR #55 CLOSED; NO FURTHER ACTION. Based on field meeting with BIH on 1/17/12; this work will be completed under CN 1252 as planned.		
1251-0037	082-0037	Install sewer lateral from the Gucci building (240 Stockton) to the main sewer on Maiden Lane. Work will involve plumbing modification inside building to raise invert.	3	CMB-0078	Agree	09/12/12	+27,428	After field investigation, the existing sewer lateral was found to connect to the Stockton main near Geary. However, the location where the lateral is connected to the main is inside the footprint of the UMS station, in which the main is shown in the contract plan to be slurry filled. The contract plan shows the lateral to be connected to the main on Maiden Lane but is not possible due to invert problem. At the CMB meeting on 1/18/12, Albert Hoe reported that he had instructed the design team during the design phase to investigate this lateral and make the connection to the sewer main at Maiden Lane. RE was asked to investigate if this could be a possible error and omission by the sewer design. (See Trends #44 and 45) COMPLETE, NO FURTHER ACTION; CMOD #18	CMOD #18 Approved
1251-0038	082-0038	Reimburse Synergy for JCDecaux work to remove kiosks	1	CMB-0064, CMB 0080	Agree	1/04/2012, 10/24/12	+29,273	JCDecaux refused to remove the remaining (2EA) kiosks without being paid for work already completed. The CMB approved on 1/04/12 Task Order No. 35 (Removal of 3EA sidewalk kiosks) as requested for the work already completed. On 10/24/12 the CMB approved Trend #38 removal of the remaining 2EA kiosks; work already completed and paid for as part of the approved CMB 0064 dated 01/04/12 for a total of 5EA kiosks removed. Total work priced at \$29,268. COMPLETE, NO FURTHER ACTION; CMOD #22	CMOD #22 Approved
1251-0039	082-0039	Furnish and install 2ea benches along 5th Street	1				+4,752	Requested by Muni Operation. COMPLETE, NO FURTHER ACTION; CMOD #22	CMOD #22 Approved
1251-0040	082-0040	Furnish and install AT&T Manholes 133 at Post/Stockton	6	CMB-0070	Agree	04/11/12	+45,000	AT&T requested SFMTA for Synergy to rebuild manhole 133 at Post/Stockton. COR #64 AT&T agreed to reimburse SFMTA (\$45,000) through the Form B process. COMPLETE, NO FURTHER ACTION; CMOD #14	CMOD #14 Approved
1251-0041	082-0041	Install additional 55 LF of AT&T trench to extend conduits from vault 5832 to vault 113 on O'Farrell Street	6	CMB-0070	Agree	04/11/12	+23,704	AT&T requested SFMTA for Synergy to extend their conduit from vault to vault instead of wye-casting into exiting duct bank. COR #63 AT&T agreed to reimburse SFMTA (\$23,704) through the Form B process. COMPLETE, NO FURTHER ACTION; CMOD #14	CMOD #14 Approved
1251-0042	082-0042	Install additional 95 LF of AT&T trench to extend conduits from vault 5831 to vault 129 on Geary Blvd.	6	CMB-0070	Agree	04/11/12	+31,525	AT&T requested SFMTA for Synergy to extend their conduit from vault to vault instead of wye-casting into exiting duct bank. COR #62 AT&T agreed to reimburse SFMTA (\$31,525) through the Form B process. COMPLETE, NO FURTHER ACTION; CMOD #14	CMOD #14 Approved
1251-0043	082-0043	Force account work for demolition of existing AT&T vaults 113 (Post/Stockton) and 403 (Ellis)	6	CMB-0076	Agree Conditionally	10/03/12	+52,607	Agreed cost shown in Trends 29 and 40 is for installing vaults only. Cost to demo existing vaults is tracked on force account (estimated cost at \$15k each vault). AT&T agreed to reimburse SFMTA (\$52,607) through the Form B process. CMB Agreed contingent on receipt of confirmation letter from AT&T for costs associated with these three trends (CMB 0076 approval - see Trend CN1251 #'s 72 & 80) COMPLETE, NO FURTHER ACTION; CMOD #23	CMOD #23 Approved
1251-0044	082-0044	Install new sewer lateral from Macy's West on O'Farrell including plumbing modification inside Macy's building.	3	CMB-0078	Agree	09/12/12	+11,438	Contract plan SW-4 shows an existing lateral to be connected to new main. However, the 8" lateral is too big to be connected directly to the new 14" main necessitating a new connection to the manhole. However, numerous existing utilities were in the way and required installation of a new lateral at a higher elevation. Due to the raised lateral invert, modification to the building is also needed. COMPLETE, NO FURTHER ACTION; CMOD #18	CMOD #18 Approved

- 1 - Owner Directed Change in Scope
- 2 - Unforeseen Conditions
- 3 - Errors and Omissions
- 4 - Quantity Variation
- 5 - Value Engineering
- 6 - Private Utilities
- 7 - Other

CENTRAL SUBWAY PROJECT
Project Trend/Change Control Log

Item #	Change Description	Change Type	CMB No.	Change Status		Projected Cost Impact +Exposure/(Benefit)	Comments	Contract Modification Number	
				Approval Action	Approval Date	Actual/Forecast			
1251-0045	082-0045	Install new 2 each sewer laterals on Stockton between Post and Geary	3	CMB-0078	Agree	09/12/12	+30,260	Contract plan SW-3 shows 2 each existing laterals coming from the Union Square garage to be connected to the new main at approximate sta 128+55. However, the laterals were found to be connected to the downstream end of the existing main (toward Geary), which is called for to be abandoned in 1251 to make room for the future station. (See Trends #37 and 44) COMPLETE, NO FURTHER ACTION; CMOD #18	CMOD #18 Approved
1251-0046	082-0046	Additional cost for enlarging PG&E vault 584 on O'Farrell east of Stockton	6				+80,000	The two (2) existing PG&E duct banks that were supposed to be intercepted by vault 584 were wider than shown on plan. Vault 584 was needed to be enlarged in order to capture the two (2) ductbanks. PG&E agreed to reimburse SFMTA (\$80,000) through the Form B process. COMPLETE, NO FURTHER ACTION; CMOD #24	CMOD #24 Approved
1251-0047	082-0047	Enlarge Muni Vault 900A on Stockton between Post and Geary	2	CMB-0082	Agree	10/31/12	+15,357	Contract plan JT-301 calls for an intercept vault to capture 2 (E) Muni ductbanks (DB). These DBs were found to be farther apart than shown on plan. The intercept vault needs to be widened. (CMB 0082 approval - see Trend CN1251 #'s 47, 58 & 78) COMPLETE, NO FURTHER ACTION; CMOD #26	CMOD #26 Approved
1251-0048	082-0048	Additional cost and time for stuck auger during micropile drilling	2					Contractor's hollow stem auger got stuck during drilling of micropile #27C in front of 17 Stockton. Contractor claims differing condition as cause for the stuck auger. Contractor is asking for 1 day compensable time extension. SFMTA is reviewing claim for entitlement. COR #67 RE Denied COR (City Letter 26); however Contractor will most likely send rebuttal. CLOSED; NO FURTHER ACTION.	
1251-0049	082-0049	Additional cost and time for added rebar and coordination with 17-19 Stockton Owner's contractor	2	CMB-0083	Agree	11/07/12	+9,058	Existing footing of One Stockton was found to be recessed from property line. City's response to RFI 171 called for additional rebar to compensate for the gap between back of new enclosure wall and existing footing. Also, the Owner's contractor of 17-19 Stockton asked that Synergy clear his work area so he can pour the primary wall and bring in his new switchgear. Synergy is asking 2 days compensable time extension. (CMB 0083 approval - see Trend CN1251 #'s 53, 59, and 64) COMPLETE, NO FURTHER ACTION	CMOD #27 Approved
1251-0050	082-0050	Additional cost to install a Type 770 pole foundation at a different location, install 2 each DPT mast arms and demo existing wall in conflict with OCS footing	2	CMB-0074	Agree	08/15/12	+48,898	Type 770 pole foundation at SW 5th/Folsom could not be installed per plan due to a conflict with a cistern. Only solution is to remove an existing pole foundation (recently installed in 1251 as contract work) to make room for the 770 pole foundation. At 5th/Folsom, 2 DPT mast arms (not shown in original plan) need to be installed. At Pole #811, an existing concrete wall is in conflict with pole foundation. (CMB 0074 approval - see Trend CN1251 #'s 67, 74 & 75) COMPLETE, NO FURTHER ACTION; CMOD #20	CMOD #20 Approved
1251-0051	082-0051	Intercept existing PG&E duct bank and terminate into vault 5464 at Market/Ellis	6				+23,633	PG&E requested to reroute existing duct bank running north out of MH 1803 at 4th/Pioneer Place into MH 5464 at Market/Ellis PG&E agreed to reimburse SFMTA (\$23,633) through the Form B process. COMPLETE, NO FURTHER ACTION; CMOD #24	CMOD #24 Approved
1251-0052	082-0052	Reroute unforeseen existing waterline on Geary east of Stockton	2	CMB-079	Agree	10/10/12	+27,234	An unforeseen existing waterline was found to be in conflict with PG&E vault 573 and needs to be rerouted per City's response to RFI #182. (CMB 0079 approval - see Trend CN1251 #'s 65 & 70). This is potentially a E&O issue due to unforeseen existing waterline on discovered along Geary Street (east of Stockton Street) not shown in the contract drawings. COMPLETE, NO FURTHER ACTION; CMOD #28	CMOD #28 Approved

- 1 - Owner Directed Change in Scope
- 2 - Unforeseen Conditions
- 3 - Errors and Omissions
- 4 - Quantity Variation
- 5 - Value Engineering
- 6 - Private Utilities
- 7 - Other

CENTRAL SUBWAY PROJECT
Project Trend/Change Control Log

Item #	Change Description	Change Type	CMB No.	Change Status		Projected Cost Impact +Exposure/(Benefit)	Comments	Contract Modification Number	
				Approval Action	Approval Date	Actual/Forecast			
1251-0053	082-0053	Additional cost for premium to accelerate contract work	1	CMB-083	Agree	11/07/12	+10,591	SFMTA directed Synergy to accelerate work to advance PG&E and AT&T cut-over and allow CN 1252 Contractor to start work at UMS COR #74 PG&E agreed to reimburse SFMTA (\$10,590) through the Form B process. 11/07/12 (CMB 0083 approval - see Trend CN1251#'s 49, 59, and 64) COMPLETE, NO FURTHER ACTION; CMOD #27	CMOD #27 Approved
1251-0054	082-0054	Additional waterproofing at FIDM and north end of Crate & Barrel	2				+8,151	Sidewalk in front of FIDM and north end of Crate & Barrel did not have a sub-sidewalk basement, hence the original plan did not call for waterproofing of the primary wall. While excavating for the joint trench, contractor found the existing waterproofing to be spalling and peeling off from the primary wall. COR #72 COMPLETE, NO FURTHER ACTION; CMOD #22	CMOD #22 Approved
1251-0055	082-0055	Install Swiveloc lids on all PG&E vaults	6					PG&E requested SFMTA to add this scope to the 1251 contract for safety reason. COR #72 SFMTA decided to defer this work to the 1252 contract. COMPLETE, NO FURTHER ACTION;	
1251-0056	082-0056	Additional work on force account related to sewer installation	2				+45,156	Additional work due to unforeseen and differing conditions during installation of sewer. COMPLETE, NO FURTHER ACTION; CMOD #15	CMOD #15 Approved
1251-0057	082-0057	Additional work on force account related to water installation and NRG vault demolition	2				+39,599	Additional work due to unforeseen and differing conditions during installation of water and demolish existing NRG vaults that are in conflict with utility installation. COMPLETE, NO FURTHER ACTION; CMOD #16	CMOD #16 Approved
1251-0058	082-0058	Additional streetlight conduit on 5th Street between Harrison and Bryant	2	CMB-0083	Agree	10/31/12	+17,754	The existing streetlight pullboxes new cables were supposed to be connected to per contract plan did not have power. New conduit needs to be install from the power source. COR #75 (CMB 0082 approval - see Trend CN1251 #'s 47, 76 & 78) COMPLETE, NO FURTHER ACTION; CMOD #25	CMOD #25 Approved
1251-0059	082-0059	Accelerate contract work at Barney's front	1	CMB-0083	Agree	11/07/12	+16,948	As a result of numerous meetings and complaints by Barneys, it was decided to accelerate contract work in order to restore Barneys sidewalk earlier (CMB 0083 approval - see Trend CN1251 #'s 53, 49, and 64) COMPLETE, NO FURTHER ACTION; CMOD #27	CMOD #27 Approved
1251-0060	082-0060	Final Bid Item Reconciliation	4				(508,961)	Bid item analysis for entire contract as of 6/12/12.	CMOD #30 Approved
1251-0061	082-0061	Excavate for PG&E cutover at 177 Stillman	6				+7,424	PG&E requested Synergy to excavate for PG&E cutover at 177 Stillman. Reference document: Email from Michael Lightstone dated 12/9/11 PG&E agreed to reimburse SFMTA (\$7,424) through the Form B process. COMPLETE, NO FURTHER ACTION; CMOD #24	CMOD #24 Approved
1251-0062	082-0062	Additional waterproofing at Macys Men's wall	2				+24,774	Contract did not call for waterproofing at Macys Men's wall. However, when contractor dug for the joint trench, it was found that the existing waterproofing has deteriorated and needed to be replaced. COR# 20 COMPLETE, NO FURTHER ACTION; CMOD #22	CMOD #22 Approved
1251-0063	082-0063	Excavation and restoration cost for PG&E gas tie-in and kill holes. Part II	6				+56,458	After completion of Part I (see trend 32), PG&E had offered to self-perform the excavation and restoration of the gas tie-in/kill holes because PG&E had crews available to perform the work. However, PG&E no longer have available crews, hence Synergy had to continue and finish excavating and restoring the last tie-in/kill holes. PG&E agreed to reimburse SFMTA (\$56,458) through the Form B process. COMPLETE, NO FURTHER ACTION; CMOD #24	CMOD #24 Approved
1251-0064	082-0064	Accelerate finish and detail work of AT&T and PG&E vaults	1	CMB-0083	Agree	11/07/12	+4,704	In order to expedite turn-over of AT&T and PG&E vaults, SFMTA directed Synergy to accelerate the detailing and finish work of these vaults. SFMTA will pay Synergy premium cost for OT hours. 11/07/12 - (CMB 0083 approval - see Trend CN1251 #'s 53, 59, and 49) COMPLETE, NO FURTHER ACTION; CMOD #27	CMOD #27 Approved

- 1 - Owner Directed Change in Scope
- 2 - Unforeseen Conditions
- 3 - Errors and Omissions
- 4 - Quantity Variation
- 5 - Value Engineering
- 6 - Private Utilities
- 7 - Other

CENTRAL SUBWAY PROJECT
Project Trend/Change Control Log

Item #	Change Description	Change Type	CMB No.	Change Status		Projected Cost Impact +Exposure/(Benefit)	Comments	Contract Modification Number	
				Approval Action	Approval Date	Actual/Forecast			
1251-0065	082-0065	Additional fittings for AWSS lateral and chipping of pole foundation at Market/Ellis	2	CMB-0079	Agree	10/10/12	+20,412	An existing Muni pole foundation is in the way of the AWSS lateral. Additional fittings are required to complete contract work. (CMB 0079 approval - see Trend CN1251 #'s 52 & 70) This is potentially an E & O issue due to an existing Muni pole foundation is in the way of the AWSS lateral. COMPLETE, NO FURTHER ACTION; CMOD #28	CMOD #28 Approved
1251-0066	082-0066	Intercept PG&E conduits at Vault 573 at Geary east of Stockton	6				+6,466	During installation of PG&E intercept vault 573, PG&E had incorrectly identified the conduits to be intercepted. This error was discovered during cut-over process by PG&E. PG&E agreed to reimburse SFMTA (\$6,466) through the Form B process. COMPLETE, NO FURTHER ACTION; CMOD #24	CMOD #24 Approved
1251-0067	082-0067	Additional feeder span, no-bo insulator and adjustment of guywire for the Folsom OCS bypass	3	CMB-0074	Agree	08/15/12	+32,149	SFMTA Electrical Designer had pointed out the new Folsom Bypass does not have enough capacity to power the new OCS necessitating installation of feeder spans. Also, adjustments to the guywire are necessary to mitigate conflict with new signal mast arms. COR #76 7/25/12 - RE presented COR to CMB; direction given to develop one CMod with all remaining items to be purchased for the new OCS bypass. (CMB 0074 approval - see Trend CN1251 #'s 50, 74 & 75) COMPLETE, NO FURTHER ACTION; CMOD #20	CMOD #20 Approved
1251-0068	082-0068	Extended Overhead cost from July 19, 2012 to August 16, 2012	1	CMB-0075	Agree Conditionally	10/03/12	+106,967	Contract is expected to be extended beyond the approved July 18, 2012 completion due to the following reasons: contractor was slowed due to accommodation of AT&T and PG&E cut-over, for example, contractor has to provide windows of time for AT&T to occupy its work space to provide continuity and efficiency for AT&T cut-over, contractor has to advance cleaning and detailing of vaults to turnover to AT&T and PG&E, these work are typically done as punchlist, contractor now has to sequence work and reallocate resources; SFWD cut-over is taking longer than expected; PG&E gas cut-over was delayed due to inability to access Armani building, this delay held up completion of sewer MH, SFWD connection and restoration on O'Farrell east; added change order work, i.e. additional PG&E conduit at vault 573 and additional excavation for AT&T cut-over at 240 Stockton CMB Agreed contingent on receipt of letter confirming e-mail as presented in the meeting and content viewed related to agreement and remaining actions and release of funds. COMPLETE, NO FURTHER ACTION; CMOD #24	CMOD #29 Approved
1251-0069	082-0069	Removal of abandoned PG&E gas valve (8each) and install anodes	6				+4,737	PG&E asked Synergy to remove all abandoned gas valves (8each) PG&E agreed to reimburse SFMTA (\$4,737) through the Form B process. COMPLETE, NO FURTHER ACTION; CMOD #24	CMOD #24 Approved
1251-0070	082-0070	Core drill primary wall and install interior plumbing at Armani and Disney for the fire service water cutover	2	CMB-0079	Agree	10/10/12	+14,034	Existing fire service inside the building is a thin-wall steel pipe that extends out to the previously existing sub-sidewalk basement. However, 1251 had backfilled the subsidewalk basement per contract, which now made the steel pipe susceptible to corrosion. SFWD does not want to tie-in to the steel pipe due to corrosion issue plus the fact that the pipe is thin walled, which makes welding almost impossible. A ductile iron pipe needs to be installed from the main and into the building. COR #77 (CMB 0079 approval - see Trend CN1251 #'s 52 & 65) COMPLETE, NO FURTHER ACTION; CMOD #28	CMOD #28 Approved
1251-0071	082-0071	Install a new 8" backflow preventer for the fire service inside Macys Men's building	6					The new water main (installed in the 1251 Contract) is closer to the property line than the existing backflow preventer. State law stipulates that a backflow preventer be installed in between the property's fire suppression system and the water main. The SFWD refuses to make this connection until a proper backflow preventer is installed. SFMTA will insist on Macys to install its own backflow preventer. CLOSED; NO FURTHER ACTION.	

- 1 - Owner Directed Change in Scope
- 2 - Unforeseen Conditions
- 3 - Errors and Omissions
- 4 - Quantity Variation
- 5 - Value Engineering
- 6 - Private Utilities
- 7 - Other

CENTRAL SUBWAY PROJECT
Project Trend/Change Control Log

Item #	Change Description	Change Type	CMB No.	Change Status		Projected Cost Impact +Exposure/(Benefit)	Comments	Contract Modification Number	
				Approval Action	Approval Date	Actual/Forecast			
1251-0072	082-0072	Additional AT&T trench from new vault 5829 to existing vault 127 on Geary east of Stockton	6	CMB-0076	Agree	10/03/12	+23,993	AT&T requested new conduits to maintain continuity between the 2 vaults. AT&T agreed to reimburse SFMTA (\$23,993) through the Form B process. RE Tracking work on FAR CMB Agreed contingent on receipt of confirmation letter from AT&T for costs associated with these three trends (CMB 0076 approval - see Trend CN1251 #'s 43 & 80) COMPLETE, NO FURTHER ACTION; CMOD #14	CMOD #14 Approved
1251-0073	082-0073	Additional work to install water and electrical utilities for Flower Stand on Geary west of Stockton	1				+17,966	Contract bid allowance for providing utility services for flower stands (UD-14) had been exhausted during relocation of 2 flower stands. A third and final flower stand is still needed to be relocated. COMPLETE, NO FURTHER ACTION; CMOD #22	CMOD #22 Approved
1251-0074	082-0074	Traffic Signal modification at 5th/Folsom	1	CMB-0074	Agree	08/15/12	+16,429	Due to installation of OCS bypass on Folsom between 4th and 5th Streets, a left turn signal is required at 5th/Folsom. Additional signal heads and modification to the existing traffic signal is necessary. RE Tracking work on FAR (CMB 0074 approval - see Trend CN1251 #'s 50, 67, & 75 also). COMPLETE, NO FURTHER ACTION; CMOD #20	CMOD #20 Approved
1251-0075	082-0075	Unforeseen conditions related to pole foundation installation for the Folsom OCS Bypass	2	CMB-0074	Agree	08/15/12	+12,568	Contractor encountered unforeseen concrete and brick substructures and abandoned utility lines. RE Tracking work on FAR (CMB 0082 approval - see Trend CN1251 #'s 47, 58 & 78) COMPLETE, NO FURTHER ACTION; CMOD #20	CMOD #20 Approved
1251-0076	082-0076	Adjustment to OCS on Mason Street	2/3	CMB-0082	Agree	10/31/12	+14,988	Modify bracket arm at existing Pole #511 to alleviate tension load and bending of pole. Realign trolley wire on Mason between Geary and Eddy to smoothen transition when shifting from right lane to left lane. Also, add intermediate guywire to prevent excessive sagging of bracket arms at various locations. RE Tracking work on FAR (CMB 0082 approval - see Trend CN1251 #'s 47, 58 & 78) COMPLETE, NO FURTHER ACTION; CMOD #26	CMOD #26 Approved
1251-0077	082-0077	Additional work related to Qwest, TCG and UCCO facilities	2	CMB-0081	Agree Conditionally	10/31/12	+37,181	Qwest, TCG and UCCO requested Synergy to tie-in their existing conduits into the new vaults that Synergy installed per contract. The utility companies are responsible for connecting existing conduits into new vaults, therefore, this request is considered extra work. Private Utilities companies agreed to reimburse SFMTA (\$37,181) through the Form B process. RE Tracking work on FAR CMB agreement contingent upon Cmod package to include evidence from all utilities that cost are reimbursable to SFMTA through the Form B process. COMPLETE, NO FURTHER ACTION; CMOD #25	CMOD #25 Approved
1251-0078	082-0078	Unforeseen conditions encountered during excavation and installation of OCS poles along Mason and 5th Streets.	2	CMB-0082	Agree	10/31/12	+27,645	Several obstructions, i.e. buried concrete, boulders, brick, abandoned utilities were discovered during excavation and installation of OCS poles along Mason and 5th Street. RE Tracking work on FAR (CMB 0082 approval - see Trend CN1251 #'s 47, 58 & 76) COMPLETE, NO FURTHER ACTION; CMOD #26	CMOD #26 Approved
1251-0079	082-0079	Additional work related to installation of PG&E Vaults 467, 571, 573, 586 and 594 including joint trench leading to these vaults	2				+44,530	Unforeseen conditions were encountered during installation of select PG&E vaults including joint trenches leading to these vaults. PG&E agreed to reimburse SFMTA (\$44,530) through the Form B process. RE Tracking work on FAR COMPLETE, NO FURTHER ACTION; CMOD #24	CMOD #24 Approved

- 1 - Owner Directed Change in Scope
- 2 - Unforeseen Conditions
- 3 - Errors and Omissions
- 4 - Quantity Variation
- 5 - Value Engineering
- 6 - Private Utilities
- 7 - Other

CENTRAL SUBWAY PROJECT
Project Trend/Change Control Log

Item #	Change Description	Change Type	CMB No.	Change Status		Projected Cost Impact +Exposure/(Benefit)	Comments	Contract Modification Number		
				Approval Action	Approval Date	Actual/Forecast				
1251-0080	082-0080	Additional work related to installation of AT&T Vaults 5828, 5829, 5830, 5831, 5832 and 5833 including joint trench leading to these vaults	2	CMB-0076	Agree	10/03/12	+56,806	Unforeseen conditions were encountered during installation of select AT&T vaults including joint trenches leading to these vaults. AT&T agreed to reimburse SFMTA (\$56,805) through the Form B process. CMB Agreed contingent on receipt of confirmation letter from AT&T for costs associated with these three trends (CMB 0076 approval - see Trend CN1251 #'s 43 & 72) COMPLETE, NO FURTHER ACTION; CMOD #23	CMOD #23 Approved	
1251-0081	082-0081	PG&E concrete cover versus CDF on electrical duct bank	6	CMB-0107	Agree	02/13/13	+43,882	Contract Plan JT-014 calls for CDF cover on PG&E duct bank. However, PG&E requested to use regular concrete due to heat dissipation problem with CDF. PG&E agreed to reimburse SFMTA (\$43,881) through the Form B process. 12/19/12 - Presented to CMB, direction given to finalize cost and obtain a Form B agreement with PG&E 02/13/13 - Revised CMod presented to CMB. PG&E agreed with negotiated reimbursement amount. COMPLETE, NO FURTHER ACTION	CMOD #24 Approved	
Contract 1251 Totals							+3,962,032	Total Changes to the contract in the amount of 3,962,032 represents an UNDERRUN of allocated contingency in the amount of \$1,405,265.32. Changes that will be Utility Reimbursement credits through the Form B process in the amount of \$1,224,828 will increase the UNDERRUN. Final Contract Closeout Total \$20,794,581 will be reduce by \$7,618,112 Utility Reimbursement credits for a Final Program cost of \$13,176,469 for CN 1251		
Contract 1252	COR No.	PCC No.	1252 Change Description	Change Type	CMB Change No.	Configuration Management Board Agree/Disagree	Decision Date	Actual/Forecast	Comments	Contract Modification No.
1252-0001a	1		AWSS Conflict w/ Low Pressure Water	6	CMB-0091	Agree to Merit Agree to Cost	10/10/12 01/16/13	+13,990	AWSS contract work was made more difficult by the proximity of a water line which was closer than indicated on UT-501. See COR 008 for TIA request. 10/10/12 - Merit info presented to CMB - Agreed 01/16/13 - EE brought to CMB for cost NOT TO EXCEED \$16,900 - Agreed COMPLETE; NO FURTHER ACTION: CMOD #29	CMOD #29 Executed
1252-0001b	1		AWSS Conflict w/ Low Pressure Water					+2,914	CMOD #32 Executed	
1252-0002a	2		AWSS Add. Tie-Rods 4th-Harrison	6	CMB-0086	Agree to Merit Agree to Cost	10/10/12 12/19/12	+45,792	The AWSS line must be restrained a certain distance beyond the 90 degree elbow we are installing under contract 1252. The 1252 contract work includes excavating on both sides of this 12-foot portion of pipe. Additional work scope (per Michael Smith @ DPW): Station 162+80 to 162+90 - Restrain the existing 12-inch tee to the existing pipe north of the tee. Restrain any other joints that are not restrained on the existing pipe up to the new pipe to be installed. 10/10/12 - Merit info presented to CMB - Agreed 12/19/12 - EE brought to CMB for cost NOT TO EXCEED \$58,000 - Agreed COMPLETE; NO FURTHER ACTION: CMOD #29	CMOD #29 Executed
1252-002b			AWSS Add. Tie-Rods 4th-Harrison					+9,337	CMOD #32 Executed	
1252-0003a	3		AT&T Vault Conflict-4th & Harrison	6	CMB-0092	Agree to Merit Agree to Cost	10/10/12 01/16/13	+13,263	After excavation of the roadway surface and subgrade at Fourth and Harrison streets an AT&T vault was discovered to be in conflict with the current alignment of the 42" RCP sewer main. Verbal authorization was given by an AT&T representative to make modifications to the vault. COR 003 has been submitted by BIH in response to this issue. Work is to be charged via SFMTA Form B agreement to AT&T. 10/10/12 - Merit info presented to CMB - Agreed 01/16/13 - EE brought to CMB for cost NOT TO EXCEED \$21,089 - Agreed 04/01/13 - CM team must obtain in writing from AT&T a utility agreement for cost reimbursement. COMPLETE; NO FURTHER ACTION: CMOD #29	CMOD #29 Executed

- 1 - Owner Directed Change in Scope
- 2 - Unforeseen Conditions
- 3 - Errors and Omissions
- 4 - Quantity Variation
- 5 - Value Engineering
- 6 - Private Utilities
- 7 - Other

CENTRAL SUBWAY PROJECT
Project Trend/Change Control Log

Item #		Change Description	Change Type	CMB No.	Change Status		Projected Cost Impact +Exposure/(Benefit)	Comments	Contract Modification Number
					Approval Action	Approval Date	Actual/Forecast		
1252-0003b	3	AT&T Vault Conflict-4th & Harrison					+2,749	CMOD #32 Executed	
1252-0004	6	PG&E live electrical delays	6	CMB-0088	Agree to Merit Agree to Cost	11/28/12 1/9/2013	+7,402	PG&E lines indicated on contract drawing UD-502 thru 504 were to be abandoned yet were not yet abandoned when BIH started work. They were abandoned on 5/21. 11/28/12 - Merit info presented to CMB - Agreed 01/09/13 - EE brought to CMB for cost NOT TO EXCEED \$7,600 - Agreed 04/01/13 - CM team must obtain in writing from PG&E a utility agreement or cost reimbursement. COMPLETE, NO FURTHER ACTION: CMOD #10 - Final Cost \$7,402.36	CMOD #10 Executed
1252-0005	7	Oil filled pipe @ Launch Box	2	CMB-0093	Agree to Merit Agree to Cost	1/16/13 1/16/13	+9,980	Synergy Demo Crew exposed an existing 6" steel line which had oil in it on the West side of 4th St between Harrison and Bryant. 01/16/13 - Merit info presented to CMB - Agreed 01/16/13 - EE brought to CMB for cost NOT TO EXCEED amount \$10,000 COMPLETE, NO FURTHER ACTION: CMOD #05 - Final Cost \$9,979.81	CMOD #5 Executed
1252-0006	8	TIA - Associated w/ COR 001, COR 002, and COR 003	6		Agree to Merit	10/10/12	+153,000	TIA and Overhead Costs related to COR 001, 002 and 003. 10/10/12 - Merit info associated w/COR's 001, 002 & 003 presented to CMB - Agreed. 01/30/13 Elevation Ladder documentation presented for review of unresolved issue of payment of Indirect costs for TIA submittals- COR 008	CMOD #32 Executed
1252-0007	9	MOS – Impacts due to SFWD low psi water line	2	CMB-0143	Agree to Merit Agree to Cost	11/06/13	+5,727	Live PG&E Electrical Lines Conflict: BIH was notified that PG&E had live electrical lines running through each headwall work zone @ Moscone station. 8 inch Low Pressure Water Line Conflict: Contract drawings show this utility to be abandoned and capped prior to work. Synergy struck and damaged the water line. SFWD directed Synergy to excavate a kill hole so they could properly abandon the line. 11/04/12 - COR Evaluation for No Merit presented to CMB for - Agreed. Contractor did not follow contract specification 02.30.00 and 02.41.00 requiring the Contractor to verify the locations of any City or public service utility company facilities that may be affected by excavation and to ensure no damage to existing underground facilities. 11/06/13 - Merit info presented to CMB - Agreed for partial merit of cost associated with excavating two additional "kill-holes on 06/20/12 & 06/21/12. 11/06/13 - EE brought to CMB for cost NOT TO EXCEED \$5,727.00 - Agreed COMPLETE; NO FURTHER ACTION: CMOD #26	CMOD #26 Executed
1252-0008	10	MOS - Demo PGE duct bank / SF City 911 fiber optic line	2	CMB-0094	Agree to Merit Agree to Cost	10/10/12 01/16/13	+4,916	Upon excavation of the MOS north headwall, BIH's subcontractor Synergy Project Management (SPM) uncovered a PG&E duct bank that contained a live San Francisco 911 fiber optic line. 11/14/12 - Presented to CMB - The narrative will be rewritten CMB agrees with partial merit labor work involved in supporting the utility agencies. This item will be brought back to the CMB for approval. 01/09/13 - EE brought to CMB for cost NOT TO EXCEED \$4,919.54 - Agreed 04/01/13 - CM team must obtain in writing from PG&E a utility agreement for cost reimbursement. COMPLETE; NO FURTHER ACTION: CMOD #03 - Final Cost 4,915.54	CMOD #3 Executed
1252-0009	11	MOS - Traffic Signal line re-route south headwall	6	CMB-0095	Agree to Merit Agree to Cost	01/16/13	+37,500	After potholing Synergy discovered several traffic lines which were in the proposed location of the south MOS headwall. Traffic Lines re-routed. Merit info presented to CMB - Agreed 01/16/13 - CMB - NOT TO EXCEED \$37,500 COMPLETE; NO FURTHER ACTION: CMOD #27	CMOD #27 Executed
1252-0010	12	MOS - Archaeological Standby North Headwall	2	CMB-0096	Agree to Merit Agree to Cost	12/11/12 01/16/13	+16,893	Upon excavation of the MOS north headwall, BIH's subcontractor Synergy Project Management (SPM) uncovered a layer of "Midden" or Native American debris. 12/11/12 - Merit info presented to CMB - Agreed 01/16/13 - EE brought to CMB for cost NOT TO EXCEED \$7,600 - Agreed COMPLETE; NO FURTHER ACTION: CMOD #06 - Final Cost \$16,892.96	CMOD #6 Executed

- 1 - Owner Directed Change in Scope
- 2 - Unforeseen Conditions
- 3 - Errors and Omissions
- 4 - Quantity Variation
- 5 - Value Engineering
- 6 - Private Utilities
- 7 - Other

CENTRAL SUBWAY PROJECT
Project Trend/Change Control Log

Item #	Change Description	Change Type	CMB No.	Change Status		Projected Cost Impact +Exposure/(Benefit)	Comments	Contract Modification Number
				Approval Action	Approval Date	Actual/Forecast		
1252-0011	MOS - SL conduit from PG&E vault @ north headwall	6		Agree to Merit	11/28/12	-0-	Permanent power is required to supply an existing Street Light box north of the MOS N headwall. 11/28/12 - Merit info presented to CMB - Agreed 04/01/13 - CM Team must obtain in writing from PG&E a utility agreement for cost reimbursement. Will be issued as a PCC with the approval of PG&E prior to requesting a proposal from the Contractor. CLOSED; NO FUTHER ACTION	
1252-0012	LB - Pre-Excavation for Slurry Walls	2	CMB-0087	Agree to Merit Agree to Cost	11/28/12 12/19/12	+125,000	Pre-excavation of slurry wall panels due to CDF encased sewer line. The concrete encasement was found by the Contractor to extend to a depth of 9'-11' below the top of guide wall or street surface. The 8" VCP sewer main and concrete encasement was incorrectly shown in the contract drawings to be approximately 4'-5' below the street surface. 11/28/12 - Merit info presented to CMB - Agreed 12/19/12 - EE brought to CMB for cost NOT TO EXCEED \$96,000 - Agreed COMPLETE; NO FURTHER ACTION: COMOD #33	CMOD #33 Executed
1252-0013	MOS - Impacts @ North and South Headwalls due to live utilities	6	CMB-0144	Agree to Merit Agree to Cost	11/06/13	+43,219	Standby delays related to the discovery of traffic lines within the proposed location of the south MOS headwall. 11/14/12 - COR presented to CMB. CMB requested additional revisions to the evaluation. CMB agrees with partial merit. The COR will be brought back to the CMB for approval. 11/21/12 - COR revisited at mtg for clarification the issue is related to CMB action from item 3 -7/25/12 (Mtg #88) specifically acted on 08/01/12 (CMB Mtg. 89) referred originally as Trend #15. CMB Agreed to No Merit to this contract change. 11/06/13 - Merit info presented to CMB - Agreed to DSC for equipment standby costs for a period of 16 working days. 11/06/13 - EE brought to CMB for cost NOT TO EXCEED \$43,219 - Agreed COMPLETE; NO FURTHER ACTION: CMOD #27	CMOD #27 Executed
1252-0014	UMS - Grant street 2 way conversion (e- & striping)	7				-0-	In order to implement a full street closure for Stockton Street at the UMS location the DPT recommended that Grant Street be converted from an existing one-way street to a two way street for vehicular traffic. Closed - Work is done. 07/18/12 - This potential change was brought before the CMB. Board's decision to have DPT perform the work. Work is completed. CLOSED; NO FURTHER ACTION	
1252-0015	PROJECT WIDE - Utility Demo limit reduction credit	7				-0-	BIH's subcontractor Synergy Project Management (SPM) would like to minimize the limits of utility demo at the Launch Box, Moscone station, UMS station and TBM Retrieval Shaft locations. SFMTA to BIH/SPM "Build per Plan". CLOSED; NO FURTHER ACTION	
1252-0016	UMS - Reduced Duration	5	CMB-0073	Agree Cost (Conditionally)	08/01/12	-0-	No cost change for acceleration of utility relocation, ground improvements (jet grouting), and headwall construction at Union Square/Market Street Station. 08/01/12 - CMB approval condition upon incorporating correctness to backup documentation as required by & documented in CMB mtg. RE to prepare modification. COMPLETE; NO FURTHER ACTION: CMOD #08 - No Cost Change	CMOD #8 Executed
1252-0017	MOS - Asbestos Pipe at north headwall	2	CMB-0090	Agree to Merit Agree to Cost	12/12/12 01/09/13	+5,707	Upon excavation of the MOS north headwall, BIH's subcontractor Synergy Project Management (SPM) uncovered friable asbestos-laden transite pipe. 12/12/12 - Merit info presented to CMB - Agreed 01/09/13 - EE brought to CMB for cost NOT TO EXCEED \$6,000 - Agreed COMPLETE; NO FURTHER ACTION: CMOD #05 - Final Cost \$5,707.05	CMOD #5 Executed
1252-0018	MOS - Brick Wall #2 discovered @ north headwall	2				+15,784	Upon excavation of the MOS north headwall, BIH's subcontractor Synergy Project Management (SPM) uncovered a buried wall. 11/14/12 - COR presented to CMB. Evaluation for merit will be rewritten and brought back to CMB for approval. 11/21/12 - Evaluation of merit presented to CMB - Agreed to No Merit to this contract change.	
1252-0019	MOS - Asbestos Pipe at south headwall	2	CMB-0085	Agree to Merit Agree to Cost	12/12/12 01/09/13	+27,630	Transite pipe was discovered during MOS south headwall excavation. 12/12/12 - Merit info presented to CMB - Agreed 01/09/13 EE brought to CMB for cost NOT TO EXCEED \$30,000 - Agreed COMPLETE; NO FURTHER ACTION: CMOD #15 COMPLETE, NO FURTHER ACTION: CMOD#15 - Final Cost \$27,629.64	CMOD #15 Executed

- 1 - Owner Directed Change in Scope
- 2 - Unforeseen Conditions
- 3 - Errors and Omissions
- 4 - Quantity Variation
- 5 - Value Engineering
- 6 - Private Utilities
- 7 - Other

CENTRAL SUBWAY PROJECT
Project Trend/Change Control Log

Item #		Change Description	Change Type	CMB No.	Change Status		Projected Cost Impact +Exposure/(Benefit)	Comments	Contract Modification Number
					Approval Action	Approval Date	Actual/Forecast		
1252-0020	27	MOS - Oil filled pipe at south headwall	2	CMB-0089	Agree to Merit Agree to Cost	12/12/12 01/09/13	+8,226	A pipe containing oil was discovered during MOS south headwall excavation. 12/12/12 - Merit info presented to CMB - Agreed 01/09/13 CMB - NOT TO EXCEED \$8,600 COMPLETE, NO FURTHER ACTION: CMOD #05 - Final Cost \$8,225.68	CMOD #5 Executed
1252-0021	29	MOS - Todco scaffolding reimbursement	2	CMB-0097	Agree to Merit Agree to Cost	12/12/12 01/16/13	+1,718	1252 contract work requires the removal of scaffolding erected by Fine Line Construction, the contractor performing renovations on the Woolf House. 12/12/12 - Merit info presented to CMB - Agreed 01/09/13 - EE brought to CMB for cost NOT TO EXCEED \$1,717 - Agreed COMPLETE, NO FURTHER ACTION: CMOD #03 - Final Cost \$1,717.83	CMOD #3 Executed
1252-0022	closed	Disputed Work Items - NTP2 vs. NTP3	7				-0-	BIH interpretation of Special Provisions SP-3 NTP2 description includes activities that SFMTA interprets to be within NTP3. These activities include: Ellis Street and Green Street shafts and associated compensation grouting, MOS headwalls and jet grouting, jet grouting at cross passage 5, UMS head walls and jet grouting, OCS removal along Stockton Street from Geary to Ellis, and the TBM retrieval shaft. On April 13, SFMTA released the MOS headwalls and jet grouting, jet grouting at cross passage 5, UMS jet grouting, OCS removal along Stockton Street from Geary to Ellis, and preparatory and utility work necessary for the construction of the retrieval shaft. CLOSED; NO FURTHER ACTION	
1252-0023		Manhole in east guidewall footprint	2				-0-	While performing excavation for the east side guidewalls at the TBM Launch Box, BIH's subcontractor CJA-NCC encountered a manhole near the bottom of the excavation which was unexpected. BIH has stated that removal of the manhole prior to the installation of the guidewalls was necessary to ensure the successful installation of the slurry walls. 05/20/12 - CM Team comment: Synergy traded this COR with SFMTA for shallow Force Main Installation. CLOSED; NO FURTHER ACTION	
1252-0024	closed	2" gas line inside 16" casing	2				-0-	While performing excavation for the Sewer and AWSS trench at the intersection of Fourth and Harrison streets, BIHJV's subcontractor Synergy encountered what was identified to be a 16" depressurized gas main. This gas main contained a 2" gas line which is shown on contract drawing UD-502 to be abandoned/removed. CLOSED; NO FURTHER ACTION	
1252-0025	5	CDF Encasement on 42" RCP	2				+95,000	While performing excavation for the east side guidewalls at the TBM Launch Box, BIH's subcontractor CJA/NCC encountered a CDF backfill at the existing 42" RCP sewer which reportedly had a significantly higher compressive strength than the 50-150 psi. which was anticipated. BIH claims that the CDF conflicted with the construction of the guidewalls and it could not be excavated by conventional means. Escalated to the IRL process	
1252-0026	closed	Damage to Live LPW main at 4th and Folsom	2				-0-	Synergy Demo Crew hit a blow-off valve on the 8" water line at the Southwest corner of the MOS headwalls. SFWD is to install a permanent cap per contract drawing WD-404. CLOSED; NO FURTHER ACTION	
1252-0027		MOS - 76 Gas Station fencing	1				-0-	SFMTA requested BIH to install fencing around the perimeter of the 76 gas station at 4th and Folsom St. Issue closed, cost of fence paid by BIH in return for use of gas station lot. CMB - Temporary use of 800 Folsom Street site for construction staging. Use of this site would be a tradeoff between SFMTA and BIH. The Contractor would maintain the sites security and up-keep in exchange for not billing. CLOSED; NO FURTHER ACTION	
1252-0028		LB - SPTC delays due to concrete encased 8" sewer	2				-0-	Closed. Combined with COR 015. 07/25/12 - Verbal information presented to CMB as a potential change. CLOSED; NO FURTHER ACTION	

- 1 - Owner Directed Change in Scope
- 2 - Unforeseen Conditions
- 3 - Errors and Omissions
- 4 - Quantity Variation
- 5 - Value Engineering
- 6 - Private Utilities
- 7 - Other

CENTRAL SUBWAY PROJECT
Project Trend/Change Control Log

Item #		Change Description	Change Type	CMB No.	Change Status		Projected Cost Impact +Exposure/(Benefit)	Comments	Contract Modification Number
					Approval Action	Approval Date	Actual/Forecast		
1252-0029	18	MOS - South Headwall re-design	1	CMB-0158	Agree to Cost	05/21/14	+144,000	Costs related to leave end stops in place and a "T-Section" at the Moscone headwalls return walls. 11/14/12 - Presented to CMB. RE is recommending a possible compensation value of \$135K. CMB agrees with partial merit for labor and material cost of this COR. RE will proceed with scoping the work. 04/17/13 - Elevation Ladder of unresolved issue of End Stops presented to CMB - COR 018 09/18/13 - Contractor has submitted a Contract Claim No. 1 Permanent End Stops at MOS Headwall for \$169,379.17. CMB directed the CM Team to draft a letter rejecting the claim. Claim #1 has been negotiated for \$144K. CMod will be issued. 05/21/14 - RON for (COR 18) presented to the CMB to approve the process of issuing the CMod for a NTE of \$140K.	CMOD #30 Executed
1252-0030	24	Ellis - Utility demolition	3	CMB-0135	Agree to Merit Agree to Cost	12/6/2012 10/09/13	+35,628	BIH says that no utilities were shown at Ellis; however, Reference Drawing UE-126 shows utilities. 12/06/12 - Merit info presented to CMB - Agreed 10/09/13 - Engineers Cost Comparison brought to CMB for cost NOT TO EXCEED \$35,628.22 - Agreed COMPLETE; NO FURTHER ACTION: CMOD #26	CMOD #26 Executed
1252-0031		Crack Gauges	4				-0-	BIH disagrees with SFMTA on the total number of crack gauges to be installed on the project. Per the contract drawings a total of 926 crack gauges are to be installed. BIH claims that a total of 50 are to be installed. CLOSED; NO FURTHER ACTION	
1252-0032	28	Ellis asbestos abatement	2		Agree to Merit	12/06/12	-0-	A steam line containing asbestos was discovered during potholing at the Ellis Street Shaft. 12/06/12 - Merit info presented to CMB - Agreed 01/10/13 - CM Comment - To be paid out of Environmental Mitigation allowance GE-8.	
1252-0033	30	LB - Class 1 Hazardous Material Haul Off	2	CMB-0159	Agree to Cost	05/21/14	+400,000	BIH trucking costs for Class 1 haul off generated at staging yard. Also see COR 054 regarding Class 1 Haz material haul off for Phase 2. 09/18/13 - Contractor has submitted a Contract Claim No. 2 Haz Mat Removal - Caltrans site (COR 30, 45 & 75) for 708,929.00 CMB directed the CM Team to draft a letter rejecting the claim. Claim #2 has been negotiated for \$400K cost to include COR's 030, 054 & 075. 05/21/14 - RON for (COR 30, 54 & 75) presented to the CMB to approve the process of issuing the CMod for a NTE of \$400K.	
1252-0034a	70	LB - Jet Grout Quantity Overrun	4	CMB-0115	Agree to Merit Agree to Cost	03/20/13 04/03/13	+599,900	The contract drawings call for the contractor to determine the extent of jet grouting at the launch box. Bid Item ES-3 has an estimated quantity of 2,831 CY of in-situ treated ground. The Contractor has currently installed 3,929 CY of Soilcrete (Jet Grout) for ground treatment. This translates to an additional quantity of 1,098 CY of ground treatment beyond the quantity listed for Bid Item ES-3. By subtracting 241 CY for the "scallop" portion of the columns the total is 857 CY. 03/20/13 - Merit info presented to CMB - Agreed 04/03/13 - EE brought to CMB for cost NOT TO EXCEED \$599,900 - Agreed COMPLETE; NO FURTHER ACTION: CMOD #22 - Contractor may pursue addl amt. \$168,700 for "scallop" portion of jet grout.	CMOD #22 Executed
1252-0034b	70	LB - Jet Grout Quantity Overrun	0	CMB-0163	Agree to Cost	7/2/14	+168,700	07/02/14 - Claim #4 presented for approval of negotiated cost NTE for for grout overrun quantities CMB agreed to \$168,700K.	
1252-0035	unsubmitted	Utility Removal UD-304 and UD-503	6				-0-		

- 1 - Owner Directed Change in Scope
- 2 - Unforeseen Conditions
- 3 - Errors and Omissions
- 4 - Quantity Variation
- 5 - Value Engineering
- 6 - Private Utilities
- 7 - Other

CENTRAL SUBWAY PROJECT
Project Trend/Change Control Log

Item #		Change Description	Change Type	CMB No.	Change Status		Projected Cost Impact +Exposure/(Benefit)	Comments	Contract Modification Number
					Approval Action	Approval Date	Actual/Forecast		
1252-0036	35	Additional Road Base on Fourth Street	2				-0-	BIH's subcontractor Synergy Project Management (SPM) discovered what they believe to be an additional layer of road base under the existing asphalt and road base layer while performing roadway demo work along the west side of Fourth street between Harrison and Bryant St. The additional layer is estimated by BIH/SPM to be approximately 8" - 12" thick. 12/06/12 - Evaluation of merit presented to CMB - Agreed to No Merit for this change. CLOSED; NO FURTHER ACTION	
1252-0037	unsubmitted	DPW permitting potential impacts	7				-0-	DPW Permitting issue to cause potential impacts. DPW is not issuing BIH permits for excavating the MOS headwalls, jet grouting at the LB, and excavating support at the LB, as they claim to have not been able to conduct a thorough review of the project's design documents and were not included in the design process. BIH may be required to re-sequence and stand many other potential impacts w/o said permits. COR package not submitted by Contractor. CLOSED; NO FURTHER ACTION	
1252-0038	38	Manhole in West Guidewall Footprint	3	CMB-0101	Agree to Merit Agree to Cost	12/05/12 01/23/13	+3,821	While performing excavation for the west side guidewalls at the TBM Launch Box, BIH's subcontractor CJA-NCC unexpectedly encountered a manhole foundation within the excavation at approximate station 165+70. It was necessary to chip away a portion of the existing manhole to gain the necessary clearance to construct the west slurry wall. 12/05/12 - CMB agreed with Evaluation of Merit 01/23/13 - EE brought to CMB for cost NOT TO EXCEED \$4,052.17 - Agreed COMPLETE; NO FURTHER ACTION: CMOD #12 - Final Cost \$3,820.84	CMOD #12 Executed
1252-0039	unsubmitted	Panel W-33 Obstruction	2				TBD	While performing excavation for the slurry walls at the TBM Launch Box, BIH's subcontractor CJA-NCC unexpectedly encountered buried (wood pile?) debris located approximately 12 feet below the guide wall within Launch Box Diaphragm Wall Panel W-33, This trend is being tracked separately from Trend 20 because we believe it may be a different structure. BIH has not provided adequate information substantiating the merging of the two trends. CLOSED; NO FURTHER ACTION	
1252-0040	PCC 1	PCC No.1 - Revisions to Moscone North Headwall Elevation (Top)	1	CMB-0099	Agree to Cost	01/16/13	+20,358	SFMTA initiated change to revise headwall elevations to facilitate a change in the roof elevation of MOS station. 01/16/13 CMB - NOT TO EXCEED \$20,500 Item is now being tracked as PCC 01 COMPLETE; NO FURTHER ACTION: CMOD #07 - Final Cost \$20,358.23	CMOD #7 Executed
1252-0041	PCC 2	PCC No. 2 - Revisions to UMS Headwall Concrete and Reinforcement Limits	1				-0-	SFMTA initiated change to revise UMS headwall concrete and reinforcement limits to provide a cost savings. 08/29/12 - Revised PCC presented to CMB PCC No longer being pursued. CLOSED; NO FURTHER ACTION	
1252-0042	31	Retrieval Shaft - Unmarked 12" Steel Pipe	2	CMB-0108	Agree to Merit Agree to Cost	01/02/13 02/27/13	+1,200	While performing excavation for the joint trench at the retrieval shaft BIH's subcontractor Synergy Project Management (SPM) discovered an abandoned 12" dia. steel pipe which appears to run continuously under Columbus Ave. 01/02/13 - Merit info presented to CMB - Agreed 02/27/13 - EE brought to CMB for cost NOT TO EXCEED \$1,250 - Agreed 04/01/13 - No reimbursement from SFWD. COMPLETE; NO FURTHER ACTION: CMOD #13 - Final Cost \$1,200	CMOD #13 Executed
1252-0043a	32	LB - Panel W29 Wood Pile	2	CMB-0136	Agree to Merit Agree to Cost	11/28/2012 11/06/13	+41,961	While performing excavation for the slurry walls at the TBM Launch Box, BIH's subcontractor CJA-NCC unexpectedly encountered what appeared to be a wood pile within Launch Box Diaphragm Wall Panel W-29. 11/28/12 - Merit info presented to CMB - Agreed 11/06/13 - EE brought to CMB for cost NOT TO EXCEED \$41,961 - Agreed Direct Cost for CORs 32, 34, 42, 43, 62, 65, 67 have been negotiated. Time Impacts in IRL process. 02/19/14 - Direct cost for COR will be paid as agreed by both parties. Time and Delay claimed by the Contractor will be denied. COMPLETE; NO FURTHER ACTION: CMOD #31	CMOD #31 Executed

- 1 - Owner Directed Change in Scope
- 2 - Unforeseen Conditions
- 3 - Errors and Omissions
- 4 - Quantity Variation
- 5 - Value Engineering
- 6 - Private Utilities
- 7 - Other

CENTRAL SUBWAY PROJECT
Project Trend/Change Control Log

Item #		Change Description	Change Type	CMB No.	Change Status		Projected Cost Impact +Exposure/(Benefit)	Comments	Contract Modification Number
					Approval Action	Approval Date	Actual/Forecast		
1252-0043b	32	LB - Panel W29 Wood Pile					+69,173	In SFMTA/BIH "Issue Resolution Ladder" process for Time Impacts. Resolution not met. Direct Costs of \$41,961 (with Markups & Bonds and Insurance) related to COR 32 have been negotiated separately and processed as Contract Modification #31.	
1252-0044	33	Ret Shaft - 20" Water Line Conflict	2		Agree to Merit	11/14/12	-0-	During excavation for the joint trench at the retrieval shaft SPM discovered that the MRY Duct Bank is directly above an active 20" low pressure waterline. As a result the work at the Retrieval Shaft must reportedly be altered. 11/14/12 - Presented to CMB, the CMB agrees with some merit of this COR, element of change not define clearly. RE will proceed with scoping the work. Due to PCC 10 CLOSED; NO FURTHER ACTION	
1252-0045a	34	LB - Panel W28 Wood Pile	2	CMB-0137	Agree to Cost	11/06/13	+43,294	While performing excavation for the slurry walls at the TBM Launch Box, BIH's subcontractor CJA-NCC unexpectedly encountered what appeared to be a wood pile within Launch Box Diaphragm Wall Panel W-28. 11/06/13 - EE brought to CMB for cost NOT TO EXCEED \$43,294 - Agreed Direct Cost for CORs 32, 34, 42, 43, 62, 65, 67 have been negotiated. Time Impacts in IRL process. 02/19/14 - Direct cost for COR's will be paid as agreed by both parties. Time and Delay as claimed by the Contractor will be denied. COMPLETE; NO FURTHER ACTION: CMOD #31	CMOD #31 Executed
1252-0045b	34	LB - Panel W28 Wood Pile					+69,173		
1252-0046	36	MOS - Catch Basin @ south headwall	3				-0-	A catch basin on the NW corner of 4th and Folsom interfered with the construction of the MOS Headwalls. Removal of the catch basin was needed in order for the headwalls to be built. BIH claims the catch basin was not shown in the contract drawings. Closed due to improper notification. COR package not submitted by Contractor. CLOSED; NO FURTHER ACTION	
1252-0047	37	UMS - 12" steel pipe removal	3	CMB-0132	Agree to Merit Agree to Cost	6/5/2013 08/28/13	+3,379	A 12" steel pipe at the north UMS headwall location interfered with the demolition of other existing UMS utilities. BIH claims the steel pipe was not shown in the contract drawings. 06/05/13 - Merit info presented to CMB - Agreed 08/28/13 - EE brought to CMB for cost NOT TO EXCEED \$3,379.19 - Agreed COMPLETE; NO FURTHER ACTION: CMOD #26	CMOD #26 Executed
1252-0048	39	MOS - 16" Steel Pipe removal @ northeast headwall	3	CMB-0102	Agree to Cost	01/23/13	+2,952	SPM removed an unmarked 16" steel pipe from the excavation of the NE MOS Headwall. Construction of the MOS headwall could not commence without this utility being removed. BIH claims the 16" steel pipe was not shown in the contract drawings. 01/23/13 - EE brought to CMB for cost NOT TO EXCEED amount \$2,951.99 - Agreed 04/01/13 - CM team must obtain in writing from PG&E a utility agreement for cost reimbursement. COMPLETE; NO FURTHER ACTION: CMOD #14 - Final Cost \$2,951.99	CMOD #14 Executed
1252-0049	40	MOS - Extra Road Base @ northeast headwall	2				-0-	BIH's subcontractor Synergy Project Management (SPM) discovered what they believe to be an additional layer of road base under the existing asphalt at the NE MOS headwall location. The road base in this location was approx. 20" thick on a patch that was roughly 25' x 25'. Closed due to improper notification. CLOSED; NO FURTHER ACTION	
1252-0050	41	LB - Impacts due to live PG&E electrical lines (Synergy)	6	CMB-0098	Agree to Merit Agree to Cost	01/16/13	+1,217	Based on direction from the SFMTA, Synergy provided a full time flagger for one night shift of work @ the intersection of I-80 off-ramp near 4th/Bryant streets in order to assist PGE while they performed the abandoning of the existing live PGE electrical at the Launch Box location which was shown to be dead in the contract drawings. 01/13/13 - CMB agreed with Evaluation of Merit 01/16/13 - EE brought to CMB for cost NOT TO EXCEED \$1,245 04/01/13 - CM team must obtain in writing from PG&E a utility agreement for cost reimbursement. COMPLETE; NO FURTHER ACTION: CMOD #10 - Final Cost \$1,216.60	CMOD #10 Executed
1252-0051	executed	Contract Amendment No. 2	1				(3,040,713)	COMPLETE; NO FURTHER ACTION: CMOD #02	CMOD #2 Executed

- 1 - Owner Directed Change in Scope
- 2 - Unforeseen Conditions
- 3 - Errors and Omissions
- 4 - Quantity Variation
- 5 - Value Engineering
- 6 - Private Utilities
- 7 - Other

CENTRAL SUBWAY PROJECT
Project Trend/Change Control Log

Item #		Change Description	Change Type	CMB No.	Change Status		Projected Cost Impact +Exposure/(Benefit)	Comments	Contract Modification Number
					Approval Action	Approval Date	Actual/Forecast		
1252-0052a	42	LB - Panel W25 Wood Pile	2	CMB-0138	Agree to Merit Agree to Cost	11/28/12 11/16/13	+42,893	While performing excavation for the slurry walls at the TBM Launch Box, BIH's subcontractor CJA-NCC unexpectedly encountered an obstruction within Launch Box Diaphragm Wall Panel W-25. 11/28/12 - Evaluation of merit presented - CMB agreed 11/06/13 - EE brought to CMB for cost NOT TO EXCEED \$42,894 - Agreed Direct Cost for CORs 32, 34, 42, 43, 62, 65, 67 have been negotiated. Time Impacts in IRL process. 02/19/14 - Direct Cost for COR's will be paid as agreed by both parties. Time and Delay claimed by the Contractor will be denied. COMPLETE; NO FURTHER ACTION: CMOD #31	CMOD #31 Executed
1252-0052b							+69,173	In SFMTA/BIH "Issue Resolution Ladder" process for Time Impacts. Resolution not met. Amount shown is for potential costs associated with time impacts. Amount is calculated = \$484,210 / 7 (7ea. CORs 32,34, 42, 43, 62, 65, 67)	
1252-0053a	43	LB - Panel W30 Wood Pile	2	CMB-0139	Agree to Merit Agree to Cost	11/28/12 11/06/13	+14,197	While performing excavation for the slurry walls at the TBM Launch Box, BIH's subcontractor CJA-NCC unexpectedly encountered an obstruction within Launch Box Diaphragm Wall Panel W-30. 11/28/12 - CMB agreed with Evaluation of Merit 11/06/13 - EE brought to CMB for cost NOT TO EXCEED \$14,197 - Agreed Direct Cost for CORs 32, 34, 42, 43, 62, 65, 67 have been negotiated. Time Impacts in IRL process. 02/19/14 - Direct cost for COR's will be paid as agreed to by both parties. Time and Delay claimed by the Contractor will be denied. COMPLETE; NO FURTHER ACTION: CMOD #31	CMOD #31 Executed
1252-0053b	43	LB - Panel W30 Wood Pile	0				+69,173		
1252-0054	44	MOS - 16" steel pipe removal @ southeast headwall	3	CMB-0109	Agree to Merit Agree to Cost	12/06/12 02/27/13	+1,600	SPM removed an unmarked 16" steel pipe from the excavation of the NE MOS Headwall. Construction of the MOS headwall could not commence without this utility being removed. BIH claims the 16" steel pipe was not shown in the contract drawings. 12/06/12 - CMB agreed with Evaluation of Merit 02/27/13 - EE brought to CMB for cost NOT TO EXCEED \$1,800 - Agreed COMPLETE; NO FURTHER ACTION: CMOD #14 - Final Cost \$1,600	CMOD #14 Executed
1252-0055	45	Ret Shaft - Credit for reduced AT&T conduits	6				(331)	Credit to install 2 less conduits in the AT&T infrastructure at the Retrieval Shaft Joint Trench. The conduit notes on page JT-701 of the contract documents require 8 EA 4" conduits as laid out on the AT&T line. The reduced materials would result in 6 EA 4" conduits as a result. 04/01/13 - CM team must obtain in writing from AT&T a utility agreement for cost reimbursement. 09/18/13 - Contractor has submitted a Contract Claim No. 2 Haz Mat Removal - Caltrans site (COR 30, 45 & 75) for 708,929.00. The CMB directed the CM Team to draft a letter rejecting the claim. COMPLETE; NO FURTHER ACTION: CMOD #26	CMOD #26 Executed
1252-0056	46	UMS - Unmarked steel pipes (6", 12", 14") / Duct Bank	6	CMB-0103	Agree to Merit Agree to Cost	12/06/12 01/23/13	+7,475	While performing excavation for the utility demolition at the south UMS headwall BIH/Synergy discovered a 6" dia. steel pipe, 16" dia. steel pipe, 18" dia. steel pipe, and a concrete duct bank. BIH claims the utilities were not shown in the contract drawings. 12/06/12 - CMB agreed with Evaluation of Merit 01/23/13 - EE brought to CMB for cost NOT TO EXCEED \$7,461 - Agreed COMPLETE; NO FURTHER ACTION: CMOD #16 - Final Cost \$7,475.28	CMOD #16 Executed
1252-0057	47	Ret Shaft - unmarked 10" steel pipe/duct bank	6	CMB-0104	Agree to Merit Agree to Cost	12/06/12 01/23/13	+2,108	Synergy Project Management (SPM), discovered an abandoned duct bank and 10" steel pipe which traveled underneath Columbus Avenue between Powell and Union Streets. Removal of the duct bank was necessary to complete the construction of the 36" RCP sewer main relocation work in this area. The status of the removal of the steel pipe is uncertain and may have not been necessary for the sewer main relocation. 12/06/12 - CMB agreed with Evaluation of Merit 01/23/13 - CMB - Not to Exceed \$2,201 04/01/13 - No reimbursement from SFWD COMPLETE; NO FURTHER ACTION: CMOD #13 - Final Cost \$2,108.04	CMOD #13 Executed

- 1 - Owner Directed Change in Scope
- 2 - Unforeseen Conditions
- 3 - Errors and Omissions
- 4 - Quantity Variation
- 5 - Value Engineering
- 6 - Private Utilities
- 7 - Other

CENTRAL SUBWAY PROJECT
Project Trend/Change Control Log

Item #		Change Description	Change Type	CMB No.	Change Status		Projected Cost Impact +Exposure/(Benefit)	Comments	Contract Modification Number
					Approval Action	Approval Date	Actual/Forecast		
1252-0058	48	UMS - 3'x5' brick sewer at south headwall	6	CMB-0114	Agree to Merit Agree to Cost	12/06/12 03/13/13	+11,675	Synergy Project Management (SPM), discovered a brick sewer within the utility demolition limits at the UMS South headwall. The sewer encountered was larger than the 12" pipe which was shown in the contract drawings. Removal and disposal of the sewer commenced on September 26th and was completed by September 28th. Removal of the sewer was necessary for headwall construction. 12/06/12 - CMB agreed with Evaluation of Merit 03/13/13 - EE brought to CMB for cost NOT TO EXCEED \$12,474.65 - Agreed COMPLETE; NO FURTHER ACTION: CMOD #16 - Final Cost \$11,675.00	CMOD #16 Executed
1252-0059	49	Ret Shaft - Tree trimming debris haul off	7				-0-	Synergy Project Management (SPM), was requested by the SFMTA to remove and dispose of debris near the Northeast corner of Columbus Avenue and Union Street. The debris resulted from tree trimming activities performed by MUNI operations. SFMTA Letter No. 119 of no merit sent to Contractor. CLOSED; NO FURTHER ACTION	
1252-0060	50	Ret Shaft - 12" steel pipe removal at Union/Columbus	6	CMB-0110	Agree to Merit Agree to Cost	12/12/12 02/27/13	+2,200	On October 4th 2012, the Contractor discovered and removed a 12" Steel pipe at the intersection of Union Street and Columbus Avenue. Removal and disposal of the steel pipe was necessary in order to complete the proposed sewer re-location work near the Retrieval Shaft. Sewer work included the construction of a manhole which had been positioned in the field to avoid an existing MUNI duct bank. 12/12/12 - CMB agreed with Evaluation of Merit 02/27/13 - EE brought to CMB for cost NOT TO EXCEED \$2,600 - Agreed 04/01/13 - No reimbursement from SFWD COMPLETE; NO FURTHER ACTION: CMOD #13 - Final Cost \$2,200	CMOD #13 Executed
1252-0061	51	Ret Shaft - Elevation design conflict (30" low psi water / sewer)	3	CMB-0123	Agree to Merit Agree to Cost	03/13/13 7/10/2013	+13,386	03/13/13 - Merit info presented to CMB - Agreed 07/10/13 EE brought to CMB for cost NOT TO EXCEED \$21,100. COMPLETE; NO FURTHER ACTION: CMOD #26	CMOD #26 Executed
1252-0062	53	Chinatown - Night drilling for instrumentation	7				-0-	Closed.	
1252-0063	54	LB Class 2 Hazardous Material Haul Off (Phase 2)	2	CMB-0159	Agree to Cost	05/21/14	-0-	BIH trucking costs for Class 1 haul off generated at staging yard. Also see COR 030 regarding Class 1 Haz material haul off for Phase 1. Claim #2 has been negotiated cost to include COR's 030, 054 & 075. 05/21/14 - RON for (COR 30, 54 & 75) presented to the CMB to approve the process of issuing the CMod for a NTE of \$400K.	
1252-0064		PCC 4 PCC No. 4 - Ret shaft sewer pipe material change	1				-0-	Change approximately 65 ft. of pipe for sewer bypass around the TBM Retrieval Shaft from 3' X 5' oval glass fiber reinforced pipe to a 48-inch (OD) HDPE SD-17 pipe with casing insulator placed inside a 54-inch diameter, ½-inch thick steel casing pipe. In addition, delete permanent sheet pile wall that was to have been placed along the west side of the trench to facilitate future maintenance access to the sewer along the shaft. CLOSED; NO FURTHER ACTION	
1252-0065		PCC 8 PCC No. 8 - UMS - Tree Removal	1				-0-	SFMTA is directing removal of a tree at the northeast corner of Stockton and O'Farrell St. CLOSED; NO FURTHER ACTION	
1252-0066		PCC 5 PCC No. 5 - Ret Shaft Water Dist. Pipe Material Change	1				-0-	Change material type of approximately 188 linear feet of 20-inch water line and approximately 125 linear feet of 30-inch water line from Welded Steel Pipe (WSP) to Ductile Iron Pipe (DIP) with TR-Flex joints. Install 6-inch thick concrete cap over 20-inch water line where cover is less than 24 inches. CLOSED; NO FURTHER ACTION	
1252-0067	58	Ret Shaft - Additional 10" steel pipe removal	6	CMB-0111	Agree to Merit Agree to Cost	12/12/12 02/27/13	+700	Work is a continuation of work performed in COR 047. 12/12/12 - CMB agreed with Evaluation of Merit 02/27/13 - EE brought to CMB for cost NOT TO EXCEED \$860.85 - Agreed COMPLETE; NO FURTHER ACTION: CMOD #13 - Final Cost \$700	CMOD #13 Executed

- 1 - Owner Directed Change in Scope
- 2 - Unforeseen Conditions
- 3 - Errors and Omissions
- 4 - Quantity Variation
- 5 - Value Engineering
- 6 - Private Utilities
- 7 - Other

CENTRAL SUBWAY PROJECT
Project Trend/Change Control Log

Item #	Change Description	Change Type	CMB No.	Change Status		Projected Cost Impact +Exposure/(Benefit)	Comments	Contract Modification Number
				Approval Action	Approval Date	Actual/Forecast		
1252-0068	56 PCC 3 PCC No. 3 - General Detour Signage	1	CMB-0113	Agree to Cost	10/03/12 02/27/13	-0-	Full closure of Stockton Street at Union Square was not anticipated under the 1252 Contract. The implementation of detour signage associated with the full closure of Stockton Street was to occur under the 1300 Contract. After the award of the 1252 Contract it was decided that a full closure of Stockton could be implemented to help reduce the headwall construction durations. As a result of the full closure the City Traffic Engineer has requested that a portion of the 1300 detour signs be installed now under the 1252 Contract to help alleviate traffic congestion and provide better detour signage around Union Square. 10/03/12 - PCC presented to CMB. CMB directed the RE to get a price quote from DPT do the work as a price comparison. This item will be brought back to the CMB at a later date. 11/14/12 - PCC presented to CMB. The CMB did not agree that Central Subway needed to take the lead on implementing detour signage, but suggested that the RE study the traffic activity and at the end of November report findings. 02/27/13 - Cost presented to CMB - Agreed to NTE \$6,152.60 Signs furnished and installed by SFMTA, PCC withdrawn. CLOSED; NO FURTHER ACTION	
1252-0069	PCC 6 PCC No. 6 - Supplemental instrumentation of BART tunnel lining.	1	CMB-0124 (voided) CMB-0129 (voided) CMB 0131	Agree to Merit Agree to Cost Agree to Cost	10/13/12 07/10/13 08/07/13 08/09/13	+307,861	Implement additional instrumentation of BART tunnel lining: (A) Existing bolt preload force – Determine the actual load in 12 bolts. (B) Bolt force sensor – Install 12 bolt force sensors at bolts for a total of 24 bolts. (C) Rail movement under dynamic train loading – Install dynamic strain gauges (2 per rail, 8 per tunnel). 10/31/12 - PCC presented to CMB for merit. CMB directed RE to proceed with obtaining a price quote from Contractor to perform the work. 05/08/13 - PCC 06 cost comparison was presented. CMB felt \$624K to perform the work was too high and requested IRP be contacted in writing to find out if the additional instrumentation monitoring was still warranted given the new alignment. 06/05: CS Letter No. 1972 presented - Tunnel Design Changes sent to IRP notified them of recent changes and developments in the tunneling contract. 07/10/13 - CMB - Not to Exceed \$650,127.62 IRP's response to SFMTA letter is still pending. 08/07/13 - EE brought to CMB for cost NOT TO EXCEED amount \$305K contingent upon revised estimate to reflect deletion in scope of work. 08/09/13 - Special CMB Mtg to clarify direction and approval to proceed with direction to the Contractor on extra work contained in PCC 06 (BART Work Scope reduction) The CMB Agreed to a NTE revised value of \$307,860 - Agreed COMPLETE; NO FURTHER ACTION: CMOD #19	CMOD #19 Executed
1252-0070	CORs 32, 34, 42, 43, 62, 65, 67 Full Closure of 4th Street	1				TBD	SFMTA allowed full closure of 4th Street in order to facilitate construction of Launch Box Slurry Wall Construction Week Ending 11/04/12 - 11/11/12.	
1252-0071	61 LB - Panel P-17 Buried Obstruction	2	CMB-0125	Agree to Merit	01/02/13	+377	CJA-NCC discovered an unmarked buried water main at Panel P-17, approximately 6' below the guidewall at CTL Station 165+52, while performing slurry diaphragm wall excavation. 01/02/13 - CMB agreed with Evaluation of Merit. 07/24/13 - CMB agreed to cost of reconciliation change - NTE \$1,100 - Agreed COMPLETE; NO FURTHER ACTION: CMOD #26	CMOD #26 Executed
1252-0072a	62 LB - Panel P-9 Buried Obstruction	2	CMB-0140	Agree to Merit Agree to Cost	1/23/2013 11/06/13	+41,587	CJA-NCC discovered a buried obstruction while excavating slurry diaphragm wall panel P-9 at the Launch Box location. 01/02/13 - Presented to CMB for merit, CMB did not agree. CMB suggested inspector's daily tags as backup or reference the tag numbers in the write-up when force account work is involved. 01/23/13 - Revised write up presented CMB agreed with Evaluation of Merit. 11/06/13 - EE brought to CMB for cost NOT TO EXCEED \$41,588 - Agreed Direct Cost for CORs 32, 34, 42, 43, 62, 65, 67 have been negotiated. Time Impacts in IRL process. 02/19/14 - Direct Cost for COR's will be paid as agreed to by both parties. Delay or Time claimed by the Contractor will be denied. COMPLETE; NO FURTHER ACTION: CMOD #31	CMOD #31 Executed
1252-0072b	62 LB - Panel P-9 Buried Obstruction					+69,173	In SFMTA/BIH "Issue Resolution Ladder" process for Time Impacts. Resolution not met. Amount shown is for potential costs associated with time impacts. Amount is calculated = \$484,210 / 7 (7ea. CORs 32,34, 42, 43, 62, 65, 67)	

- 1 - Owner Directed Change in Scope
- 2 - Unforeseen Conditions
- 3 - Errors and Omissions
- 4 - Quantity Variation
- 5 - Value Engineering
- 6 - Private Utilities
- 7 - Other

CENTRAL SUBWAY PROJECT
Project Trend/Change Control Log

Item #		Change Description	Change Type	CMB No.	Change Status		Projected Cost Impact +Exposure/(Benefit)	Comments	Contract Modification Number
					Approval Action	Approval Date	Actual/Forecast		
1252-0073	63	UMS - 48" Steel Pipe @ southwest headwall	2		Agree to Merit	1/23/13	-0-	BIH/Synergy encountered a buried 48" Diameter steel pipe during work at the UMS S. Headwall. The pipe is located 6 feet from the south UMS headwall and 5 feet from the face of the curb. 01/02/13 - Presented to CMB for merit, CMB did not agree. CMB suggested inspector's daily tags as backup or reference the tag numbers in the write-up when force account work is involved. 01/23/13 - Revised write up presented CMB agreed with Evaluation of Merit COR has been changed to PCC09. CLOSED; NO FURTHER ACTION	
1252-0074a	65	LB - Panel P-12 Buried Obstruction	2	CMB-0141	Agree to Merit Agree to Cost	1/23/2013 11/06/13	+40,522	CJA-NCC discovered a buried obstruction (water main) while excavating slurry diaphragm wall panel P-12 at the Launch Box location. 01/02/13 - Presented to CMB for merit, CMB did not agree. CMB suggested inspector's daily tags as backup or reference the tag numbers in the write-up when force account work is involved. 01/23/13 - Revised write up presented; CMB agreed with Evaluation of Merit. 11/06/13 - EE brought to CMB for cost NOT TO EXCEED \$40,523 - Agreed Direct Cost for CORs 32, 34, 42, 43, 62, 65, 67 have been negotiated. Time Impacts in IRL process. 02/19/14 - Direct cost for COR's will be paid as agreed to by both parties. Delay or Time claimed by the Contractor will be denied. COMPLETE; NO FURTHER ACTION: CMOD #31	CMOD #31 Executed
1252-0074b	65	LB - Panel P-12 Buried Obstruction					+69,173	In SFMTA/BIH "Issue Resolution Ladder" process for Time Impacts. Resolution not met. Amount shown is for potential costs associated with time impacts. Amount is calculated = \$484,210 / 7 (7ea. CORs 32,34, 42, 43, 62, 65, 67)	
1252-0075	66	Retrieval Shaft - Unmarked 12" Steel Pipe	2	CMB-0112	Agree to Merit Agree to Cost	01/23/13 02/27/13	+3,700	While performing excavation for the joint trench at the retrieval shaft BIH's subcontractor Synergy Project Management (SPM) discovered an abandoned 12" dia. steel pipe which appears to be a Low Pressure Water Main. 01/23/13 - Merit info presented to CMB - Agreed 02/27/13 - EE brought to CMB for cost NOT TO EXCEED amount \$3,800 04/01/13 - No reimbursement from SFWD COMPLETE; NO FURTHER ACTION: CMOD #13 - Final cost \$3,700	CMOD #13 Executed
1252-0076a	67	LB - Panel P-10 Buried Obstruction	2	CMB-0145	Agree to Merit Agree to Cost	1/23/2013 11/06/13	+9,984	CJA-NCC discovered a buried obstruction or concrete encased clay sewer pipe, approximately 7' below the top of the guide wall while excavating slurry diaphragm wall panel P-10 at the Launch Box location. 01/02/13 - Presented to CMB for merit, CMB did not agree. CMB suggested inspector's daily tags as backup be attached or reference the tag numbers in the write-up when force account work is involved. 01/23/13 - Merit info presented to CMB - Agreed 11/06/13 - EE brought to CMB for cost NOT TO EXCEED \$49,984 - Agreed Direct Cost for CORs 32, 34, 42, 43, 62, 65, 67 have been negotiated. Time Impacts in IRL process. 02/19/14 - Direct cost for COR's will be paid as agreed to by both parties. Delay or Time claimed by the Contractor will be denied. COMPLETE; NO FURTHER ACTION: CMOD #31	CMOD #31 Executed
1252-0076b	67	LB - Panel P-10 Buried Obstruction					+69,173	In SFMTA/BIH "Issue Resolution Ladder" process for Time Impacts. Resolution not met. Amount shown is for potential costs associated with time impacts. Amount is calculated = \$484,210 / 7 (7ea. CORs 32,34, 42, 43, 62, 65, 67)	
1252-0077	PCC 7	PCC No. 7 - BART Temporary Annex Wall	1	CMB-0106	Agree to Cost	01/30/13	+15,500	SFMTA is requesting Contractor construct temporary wall for Bart Annex for SFMTA use. 01/30/13 - NOT TO EXCEED Amount \$15,380 COMPLETE; NO FURTHER ACTION: CMOD #11 - Final Cost \$15,500	CMOD #11 Executed
1252-0078	PCC 9, FA CO 1	PCC No. 9 - UMS Headwall - Unknown Buried Pipe	1	CMB-0100	Agree to Merit Agree to Cost	01/16/13 01/16/13	+75,000	Related to COR 063. SFMTA instructed BIH to perform investigation into the 48" diameter steel pipe as it is a Differing Site Condition. 01/30/13 01/16/13 - EE brought to CMB for cost NOT TO EXCEED amount \$75,000 04/01/13 - CM team must obtain in writing from AT&T a utility agreement for cost reimbursement. COMPLETE; NO FURTHER ACTION: CMOD #04	CMOD #4 Executed

- 1 - Owner Directed Change in Scope
- 2 - Unforeseen Conditions
- 3 - Errors and Omissions
- 4 - Quantity Variation
- 5 - Value Engineering
- 6 - Private Utilities
- 7 - Other

CENTRAL SUBWAY PROJECT
Project Trend/Change Control Log

Item #	Change Description	Change Type	CMB No.	Change Status		Projected Cost Impact +Exposure/(Benefit)	Comments	Contract Modification Number
				Approval Action	Approval Date	Actual/Forecast		
1252-0079	PCC 10 FA CO 3 PCC No. 10 - Relocation of TBM Retrieval Shaft - Excludes Button Up Costs	1				+5,150,000	Modify Bid Item ST-4 (Construction of Base Bid Permanent Retrieval Shaft) and ES-4 (Ground Treatment at Retrieval Shaft Breakouts) to relocate the TBM Retrieval Shaft to 1731-1741 Powell Street - (Excludes Utility Button Up and Site Restoration) 01/09/13 - Draft PCC10 presented to CMB for Contractor Design Activity to be paid on Force Account. NTE value \$20K presented to CMB as a draft copy, final copy distributed to the Contractor increased to \$50K. 02/20/13 - COST IS NOT REFLECTED HERE - SCOPE IS FUNDED BY OTHER CPT 690 \$\$\$\$ 03/06/13 - Cost proposal received from BIH. SFMTA will develop a detail estimate of what is believed to be the scope of work. 03/13/13 - PCC 10 presented for CMB change approval of \$50K NTE amount to perform design activities. CMB requested CM team return with a more detailed estimate, Contractor's cost proposal of the bulleted items as listed on the PCC and backup documentation as evidence of work completed by the Contractor. COMPLETE; NO FUTHER ACTION CMOD #20 (separate funding source used - CPT 690).	CMOD #20 Executed
1252-0080	Segment Measuring Frequency	7					RFI 203.1 - In light of gauging frequency, and the difficulties of erecting a ring with cast in gaskets, BIH JV alternately proposes to assemble a ring on the Master ring at an interval of every 500th ring cast. The assembled ring would be comprised of randomly selected segments, or segments chosen by the Engineer. 12/11/13 - The CMB took exception to the deletion of the (\$1.3M) from the log without the consent of the Board. Direction was given to re-insert the credit and add a notation to the "comments section" the reasoning the dollar amount is no longer valid and should be removed. CLOSED; NO FUTHER ACTION	
1252-0081	F21 and Old Navy Instrumentation Proposal	7				TBD	Wang Technology is proposing instrumentation changes to the Liquid Level Sensors and Tilt Beams in the basements of Old Navy and Forever 21.	
1252-0082	68 UMS – AT&T Vault Walkway @ N Headwall	2		Agree to Merit	01/16/13	+2,000	SPM discovered an walkway at the UMS north headwall. This walkway is located at the UMS north headwall and connects the south AT&T vault, located within the utility demolition limits, to a north AT&T, located outside of the utility demolition limits. SPM proposes to construct 3'x5' wall to the extents necessary, inside this walkway. The wall will be constructed of plywood and necessary reinforcement in order to create a bulkhead that will isolate the walkway and north vault from the south vault. 01/16/13 - CMB recommendation Contractor/Sub-contractor proceed on Force Account with a "Not to Exceed Amount" \$2K. 04/01/13 - CM team must obtain in writing from AT&T a utility agreement for cost reimbursement. COMPLETE; NO FURTHER ACTION: CMOD #16 - Final Cost \$2,000.00	CMOD #16 Executed
1252-0083	69 UMS - Shoring Impacts due to 48" ATT Pipe at SW Headwall	2	CMB-0153	Agree to Cost	4/23/14	+29,463	On or about 10-25-13, BIH/Synergy were installing sheet piles at the UMS SW head wall to demolish the existing basement wall in conflict with the head wall construction per contract requirements. During the driving of the sheet piles, Synergy struck a buried object which was later identified as a 48" Diameter steel pipe. See PCC 9 and 11. Synergy thought they were hitting a buried tie-back which was shown on the contract drawings. Synergy did not know at the time that they were hitting a buried 48" pipe. After hitting the buried object, Synergy installed additional sheet piles and enlarged the excavation area in order to clear the buried object and drive the sheet piles to the minimum embedment depth. Due to the larger excavation, Synergy is claiming impacts as a result of encountering this DSC including shoring revisions and for installing additional sheats. 06/05/13 - CM TEAM NOTES: COR 069 reopened by BIH to cover cost for enlarging excavation due to encountering the 48" buried pipe. Previously COR 069 was to cover capping and removal of the pipe until it was changed to PCC 11. 02/05/14 - CM TEAM NOTES: In IRL process 04/23/14 - EE brought to CMB for Cost Not to Exceed \$30K - Agreed. Change will be negotiated as a lump sum.	
1252-0084	PCC 11, FA CO 2 PCC No. 11 - UMS – Cap and Remove 48" Steel pipe	1	CMB-0105	Agree to Cost	1/23/13	+150,000	BIH/Synergy encountered a buried 48" Diameter steel pipe during work at the UMS S. Headwall. The pipe is located 6 feet from the south UMS headwall and 5 feet from the face of the curb. This PCC is to complete removal of pipe @ S. Headwall and Investigate and remove pipe if necessary @ the North headwall. 01/30/13 - EE brought to CMB for cost NOT TO EXCEED amount \$150,000 - Agreed 04/01/13 - CM team must obtain in writing from AT&T a utility agreement for cost reimbursement. COMPLETE; NO FURTHER ACTION: CMOD #09	CMOD #9 Executed

- 1 - Owner Directed Change in Scope
- 2 - Unforeseen Conditions
- 3 - Errors and Omissions
- 4 - Quantity Variation
- 5 - Value Engineering
- 6 - Private Utilities
- 7 - Other

CENTRAL SUBWAY PROJECT
Project Trend/Change Control Log

Item #		Change Description	Change Type	CMB No.	Change Status		Projected Cost Impact +Exposure/(Benefit)	Comments	Contract Modification Number
					Approval Action	Approval Date	Actual/Forecast		
1252-0085	71	LB – Ramp Excavation Obstructions	2	CMB-0133	Agree to Merit Agree to Cost	4/3/2013 09/25/13	+5,594	BIHJV encountered numerous groups of wood piles while performing excavation of the Launch Box ramp. The wood piles are approximately 16"+ in diameter and are located along the north and south perimeter walls of the Launch Box ramp excavation area. 01/30/13 - CMB did not agree with merit of change suggestion the RE negotiate w/Contractor for another concession. 04/03/13 - COR merit evaluation presented to CMB again due to a greater number of obstruction encountered. CMB - Agreed to Partial Merit. 09/25/13 - EE brought to CMB for cost NOT TO EXCEED amount \$5,700. COMPLETE; NO FURTHER ACTION: CMOD #26	CMOD #26 Executed
1252-0086	72	Ellis Shaft Jet Grout Obstruction	2				-0-	On February 6th, 2013, CJA/NCC was drilling column R3 of the Ellis Shaft and reported hitting an obstruction 52ft below existing grade. The obstruction reportedly caused the jet grout monitor to shear off. At this time it is not known what the obstruction is or if it caused the monitor to be sheared off. Contractor no longer pursuing. CLOSED; NO FURTHER ACTION	
1252-0087	73	MOS - 16" Pipe removal @ NE Headwall	2	CMB-0118	Agree to Merit Agree to Cost	3/13/2013 05/08/13	+940	BIH-JV's subcontractor, Synergy, encountered an abandoned 16" pipe while installing the 12" waterline at the north headwall of Moscone. The pipe was at the same elevation as the new 12" waterline and therefore needed to be removed to facilitate the installation of the new 12" waterline. 03/13/13 - Merit info presented to CMB - Agreed 04/01/13 - CM team must obtain in writing from PG&E a utility agreement for cost reimbursement. 05/08/13 - CMB agreed to cost of reconciliation of change on FA - NTE \$989.00 - Agreed COMPLETE; NO FURTHER ACTION: CMOD #17	CMOD #17 Executed
1252-0088		Whole Foods - Unknown brick obstruction in Comp Grout Trench	0				-0-	BIH has decided not to submit a COR as production was not significantly impacted. CLOSED; NO FURTHER ACTION	
1252-0089	75	Hazardous Waste Disposal Denial - Spoils Containment Cost Impacts	7	CMB-0159	Agree to Cost	05/21/14	-0-	BIH submitted change order request (COR) 030 seeking reimbursement for the demonstrated additional costs of excavating, handling and disposing of excavated material found to contain hazardous material to a permitted landfill over that which can be disposed of at an unregulated dump site. The SFMTA refused reimbursement for such costs under the hazardous waste bid item allowance. As a result of this determination, BIH is modifying its approach to the construction and handling operations of tunnel spoils generated during tunneling operations. 09/18/13 - Contractor has submitted a Contract Claim No. 2 Haz Mat Removal - Caltrans site (COR 30, 45 & 75) for 708,929.00 CMB directed the CM Team to draft a letter rejecting the claim. Claim #2 has been negotiated to included COR 30, 54 and 75. 05/21/14 - RON for (COR 30, 54 & 75) presented to the CMB to approve the process of issuing the CMod for a NTE of \$400K.	
1252-0090	76	MOS - 16" Pipe removal @ SE Headwall	2	CMB-0119	Agree to Merit Agree to Cost	03/20/13 05/08/13	+1,116	BIH-JV's subcontractor, Synergy, encountered an abandoned 16" pipe while installing the 12" waterline at the south headwall of Moscone. The pipe was at the same elevation as the new 12" waterline and therefore needed to be removed to facilitate the installation of the new 12" waterline. 03/20/13 - Merit info presented to CMB - Agreed 04/01/13 - CM team must obtain in writing from PG&E a utility agreement for cost reimbursement. 05/08/13 - CMB agreed to cost of reconciliation of change on FA - NTE \$1,116.00 - Agreed COMPLETE; NO FURTHER ACTION: CMOD #17 - Final Cost \$1,116.00	CMOD #17 Executed
1252-0091	77	Comp Grout - WFB-5 Drilling Obstruction	2	CMB-0126	Agree to Merit Agree to Cost	04/03/13	+6,126	On March 06,2013, BIHJV encountered a potential Differing Site Condition (DSC) while drilling the compensation grouting hole WFB-5 located at Whole Foods and more precisely at CTL Station 160+38. This potential DSC consists of an obstruction located at a depth of 9' below grade which prevented CJA-NCC from drilling any further. 04/03/13 - Merit info presented to CMB - Agreed 07/24/13 - CMB agreed to cost of reconciliation change - NTE \$6,125.93 COMPLETE; NO FURTHER ACTION: CMOD #26 - Final Cost \$1,116.00	CMOD #26 Executed

- 1 - Owner Directed Change in Scope
- 2 - Unforeseen Conditions
- 3 - Errors and Omissions
- 4 - Quantity Variation
- 5 - Value Engineering
- 6 - Private Utilities
- 7 - Other

CENTRAL SUBWAY PROJECT
Project Trend/Change Control Log

Item #	Change Description	Change Type	CMB No.	Change Status		Projected Cost Impact +Exposure/(Benefit)	Comments	Contract Modification Number			
				Approval Action	Approval Date	Actual/Forecast					
1252-0092	78		Comp Grout - WF & ATT	2			Agree to Merit	3/20/13	-0-	BIHJV encountered multiple potential Differing Site Conditions (DSC's) of varying dimensions while excavating the compensation grouting trench for the drill holes located at Whole Foods and AT&T. 03/20/13 - Merit info presented to CMB - CMB agreed there was No Merit for this contract change. 05/24/13 - CM Team Notes - Contractor no longer pursuing due to failure to provide proper notification. CLOSED; NO FURTHER ACTION.	
1252-0093	79	FA CO 4	Comp Grout - Old Navy	2	CMB-0116 CMB-0142		Agree to Merit Agree to Merit (addl) Agree to Cost Agree to Addl Cost	03/20/13 04/24/13 04/26/13 11/06/13	+259,373	BIHJV encountered a potential Differing Site Condition (DSC) while sawcutting the pavement for the compensation grouting holes located at Old Navy. The original design was to drill the compensation grout holes between two existing PG&E lines. It was discovered in the field that there is not enough clearance between the existing PG&E lines for the original design to be possible and multiple other potential DSCs were also encountered including, but not limited to, tile duct banks, concrete of unknown contents, and steel pipes. 03/20/13 - Merit info presented to CMB - Agreed 04/01/13 - CM team must obtain in writing from PG&E a utility agreement for cost reimbursement. 04/24/13 - Addl info presented for rationale for Contractor to demob and remob drill rig due to insufficient clearance between existing PG&E lines to drill the grout holes - Agreed 04/26/13 - COR presented at a special CMB mtg to notifying CMB of need to have Contractor perform work on FA4 for a NTE amount of \$70K. 05/15/13 - Addl request for funds to cover (Inefficiencies) - agreed for a not to exceed amount \$152,000. 11/06/13 - EE brought to CMB for cost NOT TO EXCEED \$37,380 for the (remaining cost) parts 2 and 3 of 4 - Agreed COMPLETE; NO FURTHER ACTION: CMOD #23	CMOD #23 Executed
1252-0094	80		MOS – Asbestos Wrapped 20" water line @ Headwalls	2			Agree to Merit	04/03/13	-0-	BIHJV's subcontractor, Synergy Project Management was performing the installation of low pressure water distribution piping at the Moscone north headwall and discovered an unknown material wrapping around the existing 20" waterline which appeared to contain asbestos material. 04/03/13 - Merit info presented to CMB - Agreed 07/10/13 - CM Team Notes - To be paid out of Environmental Mitigation allowance GE-8.	
1252-0095	81		12" Waterline Tee Connection Location (MOS South)	2			Agree to Merit	04/03/13	+3,001	BIHJV's subcontractor, Synergy Project Management, encountered a potential Differing Site Condition (DSC) upon exposing the tie-in point for the 12" waterline at the south headwall of Moscone. The potential DSC consists of two 45 degree elbows in the existing 12" waterline at the point of the tee connection. SFWD has surveyed the field conditions and indicated that the tee connection will need to be moved to the west. 04/03/13 - Merit info presented to CMB - Agreed COMPLETE; NO FURTHER ACTION: CMOD #17 - Final Cost \$3,000.00	CMOD #17 Executed
1252-0096	82		MOS 20" Conflict with 16" AWSS @ South Headwall	2	CMB-0160		Agree to Merit Agree to Cost	04/30/14 05/21/14	+40,152	Upon exposing the existing 20" waterline at the south headwall of MOS, in preparation for installing the new 20" waterline shown on WD-403 and amended by RFI 0155, BIHJV's subcontractor Synergy Project Management encountered a potential DSC. The potential DSC consisted of a crossing conflict between the new 16" AWSS, the new 20" waterline, and the existing 6" PE gas. These three utilities cross at multiple locations however the existing depths are roughly the same. 01/22/14 - Item reviewed at the CMB mtg as a status update to potential cost exposure. Item now being discussed in the IRL process. 04/30/14 - Merit info presented to CMB - Agreed. RE will negotiate a credit for amount no less than \$25K. 05/21/14 - Updated info presented to the Board. Further negotiation revealed an extra 25ft was not accounted for. CMB approved a change Not to exceed \$12K to cover the difference and contractor's claim of standby cost	
1252-0097	83		Ellis Shaft Concrete Obstruction	2	CMB-0127		Agree to Merit Agree to Cost	04/17/13 07/24/13	+1,420	During excavation for the Ellis Street Shaft, BIHJV's subcontractor, CJA-NCC, encountered a concrete obstruction at approximately 10 feet below grade. CJA-NCC spent 4 hours removing the obstruction. 04/17/13 - Merit info presented to CMB - Agreed 07/24/13 - CMB agreed to cost of reconciliation change - NTE \$1,424.52 - Agreed COMPLETE; NO FURTHER ACTION: CMOD #26	CMOD #26 Executed

- 1 - Owner Directed Change in Scope
- 2 - Unforeseen Conditions
- 3 - Errors and Omissions
- 4 - Quantity Variation
- 5 - Value Engineering
- 6 - Private Utilities
- 7 - Other

CENTRAL SUBWAY PROJECT
Project Trend/Change Control Log

Item #	Change Description	Change Type	CMB No.	Change Status		Projected Cost Impact +Exposure/(Benefit)	Comments	Contract Modification Number	
				Approval Action	Approval Date	Actual/Forecast			
1252-0098	84	Crate & Barrel Water Intrusion	2				Water was discovered seeping into the Crate & Barrel basement in concert with secant pile installation at Pile #SRV-A. At the time, pile excavation was approximately 90 feet deep. BIHJV's subcontractor, CJA-NCC, stopped pile installation and placed lean concrete within the pile excavation. This allowed them to continue secant pile construction on other piles until which time SFMTA could provide appropriate mitigation for the water leak. 07/03/13 - CM Team will deny merit, notice not received within 7 days. CLOSED; NO FURTHER ACTION		
1252-0099a	PCC 12, FA CO 6	PCC No. 12 - Modifications to Tunnel Alignment at Market Street - Adv. Materials Purchase	1	CMB-131	Agree to Merit Agree to Cost (Conditionally)	08/14/13 08/14/13	+45,637	IFB Tunnel Profile conflicts with micro-piles installed under Contract 1251. Tunnel Profile needs to be revised (lowered) such that TBM and Tunnel structure is below previously installed micro-piles. Contractor shall revise compensation grouting design to conform to Contract requirements given the revised tunnel alignment. 04/03/13 - CMB agreed to Micropile profile change being forwarded to the Contractor. 04/10/13 - Updated alignment was presented superseding 04/03/10 version - (lowered 4.9%) 04/10/13 - Original Contractor submittal needs to be evaluated to verify the new alignment has been incorporated. 08/14/13 - Merit Evaluation and PCC 12 Cost NTE (Construction portion) was presented to the CMB for approval. The CMB agreed to merit contingent upon verification signature by the Designer (DP1) of additional work and cost associated with the change. NTE Value \$41,470.01 - Agreed COMPLETE; NO FURTHER ACTION; CMOD #28 - FA CO 6 (\$45,637). Actual costs to be determined. MTA may be due minor credit +/- 3k.	CMOD #28 Executed
1252-0099b	PCC 12	PCC No. 12 - Modifications to Tunnel Alignment at Market Street - Initial Design Costs					+39,930	Contractors proposal for PCC 12 is \$1,668,434. Amount shown represents Cmod 34 executed for Initial Design Costs (\$39,930).	CMOD #34 Executed
1252-0099c	PCC 12	PCC No. 12 - Modifications to Tunnel Alignment at Market Street - Construction Costs					+1,582,868	Contractors proposal for PCC 12 is \$1,668,434. Amount shown (1,582,868) represents Construction Costs proposed by Contractor. Amount under negotiations.	
1252-0100	85	SFWD Impacts at MOS North	2	CMB-162	Agree to Cost	07/02/14	+71,300	BIHJV's subcontractor CJA-NCC is in the process of constructing the Moscone Station headwalls, the sequence of construction is such that it requires the 12" and 20" waterlines on the eastside of 4th street to be rerouted prior to completing the headwalls. In accordance with the Contract the San Francisco Water Department (SFWD) is responsible for completing the waterline reroutes (chlorination and tie-in) in a specified duration. BIHJV claims the SFWD failed to complete this work in the contractual durations. As a result, BIHJV claims the headwall construction operation has been incurring stand by costs. 04/10/13 - Item reviewed at CMB meeting during review of Trend/Change Log COR's. CM team contends this is not a valid change and will reject the Contractor's claim of merit. Contractor has submitted a notification of Claim #3 for standby cost for this item. The CM Team will respond by 02/14/14. 07/02/14 - Claim #3 presented for approval of negotiated cost NTE for for grout overrun quantities CMB agreed to \$71,633K	
1252-0101	87	Cross Passage 5 - Value Engineering Change Proposal	5				(2,674)	As indicated in Contract Drawing No. ES-144, ground treatment for the excavation of CP5 was anticipated to be performed using jet grouting methods. BIHJV proposes to perform ground freezing from within the tunnels as an alternative ground treatment methodology, thereby avoiding the need to disrupt and impact the public by occupying 4th Street for an extended period. 04/24/13 - Item reviewed at CMB mtg. during review of Trend/Change Log COR's. CMB suggested a credit from the Contractor should be received for Bid Item ES-5. In addition suggested a minimal review of the BIH's proposed ground freezing method be done by the PB. COMPLETE; NO FURTHER ACTION: CMOD #25	CMOD #25 Executed
1252-0102		UMS - Secant Pile SRV-J Obstruction DSC	2				-0-	BIHJV's subcontractor, CJA-NCC, encountered a potential Differing Site Condition (DSC) while drilling for UMS Secant Pile #SRV-J. The DSC consists of what appears to be an abandoned utility pipe located approximately 10 feet deep. 04/24/13 - Information presented to CMB during review of Trend Log. CM Team states COR merit will be rejected due to notification of change not met in timely manner per the contract docs. 05/24/13 - CM Team update - Contractor no longer pursuing due to untimely notification of event. CLOSED; NO FURTHER ACTION	

- 1 - Owner Directed Change in Scope
- 2 - Unforeseen Conditions
- 3 - Errors and Omissions
- 4 - Quantity Variation
- 5 - Value Engineering
- 6 - Private Utilities
- 7 - Other

CENTRAL SUBWAY PROJECT
Project Trend/Change Control Log

Item #	Change Description	Change Type	CMB No.	Change Status		Projected Cost Impact +Exposure/(Benefit)	Comments	Contract Modification Number
				Approval Action	Approval Date	Actual/Forecast		
1252-0103	SFWD Impacts at MOS South	2				-0-	BIHJV's subcontractor CJA-NCC is in the process of constructing the Moscone Station headwalls, the sequence of construction is such that it requires the 12" and 20" waterlines on the eastside of 4th street to be rerouted prior to completing the headwalls. In accordance with the Contract the San Francisco Water Department (SFWD) is responsible for completing the waterline reroutes (chlorination and tie-in) in a specified duration. BIHJV claims the SFWD failed to complete this work in the contractual durations. As a result, BIHJV claims the headwall construction operation has been incurring stand by costs. 05/08/13 - Information presented to CMB during review of Trend Log. CM Team states COR will be rejected due to no merit. This item is not on the critical path. 06/17/13 - Contractor no longer pursuing. CLOSED; NO FURTHER ACTION	
1252-0104	PCC 13 - SFWD Excavation, Support and Backfilling	1	CMB-0122 CMB-0128	Agree to Cost Agree to Adtl Cost	06/19/13 08/09/13	+33,982	Excavation, support and restoration work at two locations required to facilitate fitting/valve installation work by the San Francisco Water Department. Installation of valves are to facilitate fire service connection cutover and cutting off of the existing water main. The existing water main is in the footprint of the UMS station piles and is to be abandoned. 06/05/13 - CMB agreed to change required; work must be completed sometime in June 2013 06/19/13 - Cost estimate presented; CMB agreed for a NTE of \$20K 08/07/13 - CMB viewed the estimate requesting the narrative be rewritten to tell the entire story of what has generated the change. 08/09/13 - Special CMB Mtg to clarify direction and approval to proceed with direction to the Contractor on extra work contained in PCC 13 (Macy's Backflow work). CMB approved additional work and scope for a NTE value of \$14,100 for a total change value of \$34,100 COMPLETE; NO FURTHER ACTION: CMOD #18 executed for \$20K. Supplementary CMOD #24 executed for \$13,982 was issue for remaining cost.	CMOD #18 & 24 Executed
1252-0105	Abandoned Well at MOS Panel N-4	2				-0-	BIHJV's subcontractor, CJA-NCC, discovered an obstruction that appears to be an abandoned monitoring well within the Moscone Slurry Wall Panel "N-4". Contractor claims impacts resulting from this alleged DSC include, but are not limited to, excavation inefficiency, the required backfilling of the panel with lean concrete on multiple occasions, and re-excavations of the panel. 06/19/13 - Information presented to CMB during review of Trend Log. CM Team states COR will be rejected due to several reasons of "no merit" items in the IRL process	
1252-0106	PCC No. 9 and 11 - Remaining Budget	0				(71,885)		
1252-0107	Credit - North headwall panel N-2 at Moscone	7				(4,943)	During installation of the reinforcement cage at panel N-2 at the Moscone North Headwall a 1-inch dia. Polyester sling used for lifting could not be detached from the reinforcement cage. The slings were then casted in-place. SFTMA requested a credit CO for the CN 1300 contractor to demolish the concrete and slings and replace the structural concrete. 07/10/13 - NCR condition of the wall be provided in order to prepare engineer's estimate for credit amount. Negotiated amount to be deducted from pay estimate. COR has been rescinded.	
1252-0108	Credit - Secant pile SRV-H, UMS south headwall	7				(263)	During concrete placement, the dummy steel beam that was used to hold down the secant pile steel beam reinforcement for pile SRV-H @ the UMS south headwall could not be removed and was poured in-place. SFTMA requested a credit CO for the CN 1300 contractor to demolish this beam between El. 16.66' and the beam top. Negotiated amount to be deducted from pay estimate. COR has been rescinded.	
1252-0109	Credit - 65 feet of water pipe not installed at MOS	7				-0-	Contract Drawings WD-403 & WD-404 shows the 20" low pressure water line cutting through an area in the intersection where the joint trench is in the way. BIHJV's subcontractor, Synergy Project Management, with SFMTA's concurrence, installed the water line tie-in per a configuration which resulted in approximately 65' less line required to be installed. SFTMA requested a credit CO to eliminate 65' of the line. CLOSED; NO FURTHER ACTION	
1252-0110	Credit - Switching of the 12" and 20" lines at MOS	3				(30,466)	It was discovered that the field locations of the 12" water line and 20" water line were actually "switched" from the location shown in contract drawing WD-402 Rev.0. SFMTA requested a credit CO as less 20" water line was required to be installed than was originally anticipated.	

- 1 - Owner Directed Change in Scope
- 2 - Unforeseen Conditions
- 3 - Errors and Omissions
- 4 - Quantity Variation
- 5 - Value Engineering
- 6 - Private Utilities
- 7 - Other

CENTRAL SUBWAY PROJECT
Project Trend/Change Control Log

Item #		Change Description	Change Type	CMB No.	Change Status		Projected Cost Impact +Exposure/(Benefit)	Comments	Contract Modification Number
					Approval Action	Approval Date	Actual/Forecast		
1252-0111	95	Green St Shaft – Design Cost Impacts for Jet Grout	7				-0-	BIHJV: "BIH and CJA-NCC are in receipt of the SFMTA's revised submittal review comments for Submittal No 31.43.14-003 (review cycle 3) dated July 10, 2013, where the SFMTA determined that the previously submitted content does not fulfill the contract requirements. The submittal status was changed from "Approved" on March 21, 2013, to "Disapproved - Resubmit" on July 10, 2013. The SFMTA states that the submittal was reviewed in further detail and it was determined the submittal didn't fulfill the contract requirements. This new submittal determination will result in additional costs to the SFMTA." 07/24/13 - Information presented to CMB during review of Trend Log. CM Team preparing letter of no merit, due to disagreement of dwg shown. CLOSED; NO FURTHER ACTION	
1252-0112	96	Micropiles @ UMS Tangent Pile SRB-H	2	CMB-0155	Agree to Merit Agree to Cost	7/31/2013 05/07/14	+48,810	Excavation for battered secant pile SRB-H began on July 12. At approximate depth of 30', CJN reported hitting an obstruction. Two, 36" and 45" long, No. 18, Dywidag bars were discovered within spoils of the first bite of the clamshell bucket. The 2-1/2" diameter bar was consistent with the micro piles installed in the previous contract. 07/24/13 - Draft merit evaluation presented to CMB. CM Team reported further investigation needed to verify survey location of micropiles. CMB requested a specific dwg of 1251 As Built of piles be presented at next CMB. 1251 Contractor will be put on notice referencing the CS CN1251 Ltr. #018 - Future Potential Costs Due to Incorrect Micropile Placement. 07/31/13 - Merit Approval presented to CMB - Agreed. Notification of Possible Micropile Obstruction to CN1252 and possible CN1300 work was sent to CN1251 Contractor. COR was rescinded. CLOSED; NO FURTHER ACTION	
1252-0113		Relocation of TBM Retrieval Shaft - Columbus Ave. Restoration	1				+261,057	Modify Bid Item GE-3 (Utility Demo, Sewer, Road Demo, Pavement Restoration, etc.) to relocate the TBM Retrieval Shaft to 1731-1741 Powell Street - (Includes Utility Button Up and Site Restoration Only) 07/24/13 - Information presented to CMB during review of Trend Log. CMB requested LS Bid Item be broken-down based on contract work to see how much money would be put in to perform the restoration button up cost. In addition the CMB requested the item description be change to "Columbus Ave. Restoration" in order to not confuse it with PCC 10 Retrieval Shaft work. COMPLETE; NO FURTHER ACTION: CMOD #21	CMOD #21 Executed
1252-0114	97	Ellis Shaft – TAM ES2-01 and ES2-17	2		Agree to Merit	08/28/13	-0-	BIHJV's subcontractor, CJA-NCC, discovered gravel material within the drill spoils from two separate Ellis Shaft TAM installations, TAM ES2-01 and ES2-17 08/14/13 - Item reviewed at CMB during review of Trend/Change Log COR's. GBR's will be checked to see if gravel material is known to exist in the drill location. 08/28/13 - Merit info presented to CMB - Agreed COR Rescinded CLOSED; NO FURTHER ACTION	
1252-0115	98	Ellis Shaft – TAM ES2-16	2		Agree to Merit	08/28/13	-0-	BIHJV's subcontractor, CJA-NCC, discovered gravel material within Ellis Shaft TAM installations, TAM ES2-16 08/14/13 - Item reviewed at CMB during review of Trend/Change Log COR's. GBR's will be checked to see if gravel material is known to exist in the drill location. 08/28/13 - Merit evaluation presented to CMB - Agreed COR Rescinded CLOSED; NO FURTHER ACTION	
1252-0116	99	MOS – AWSS Vault Over pour @ South Headwall)	2	CMB-0134	Agree to Merit Agree to Cost	09/25/13	+2,394	BIHJV: "While performing AWSS work at the MOS South Headwall, Synergy crews found the mechanical joint Tee bolts, required for the AWSS point of connection, to be completely encased in concrete. The concrete encasement appeared to be concrete over pour remaining from a previous contractor's AWSS vault wall pour." 08/14/13 - Item reviewed at CMB during review of Trend/Change Log COR's. 09/25/13 - Merit evaluation presented to CMB - Agreed. 09/25/13 - Eng. Est. presented to CMB for cost NOT TO EXCEED \$2,400 - Agreed COMPLETE; NO FURTHER ACTION: CMOD #26	CMOD #26 Executed

- 1 - Owner Directed Change in Scope
- 2 - Unforeseen Conditions
- 3 - Errors and Omissions
- 4 - Quantity Variation
- 5 - Value Engineering
- 6 - Private Utilities
- 7 - Other

CENTRAL SUBWAY PROJECT
Project Trend/Change Control Log

Item #	CMB No.	Change Description	Change Type	Change Status		Projected Cost Impact +Exposure/(Benefit)	Comments	Contract Modification Number
				Approval Action	Approval Date	Actual/Forecast		
1252-0117	100	Ellis Shaft TAM ES2-08	2		Agree to Merit	08/28/13	-0	BIHJV: "August 12,2013, BIHJV's subcontractor, CJA-NCC, struck a hard unknown object while drilling the Ellis Shaft TAM ES2-08." 08/28/13 - Merit evaluation presented to CMB - Agreed. CMB requested a investigation plan to be developed and included in this COR if the plan is implemented. COR Rescinded. CLOSED; NO FURTHER ACTION
1252-0118	101	Ellis Shaft TAM ES2-11	2				-0	BIHJV's subcontractor, CJA-NCC, discovered gravel material within Ellis Shaft TAM installations, TAM ES2-11 09/11/13 - Viewed at CMB during review of Trend/Change Log COR's. CLOSED; NO FURTHER ACTION
1252-0119	102	UMS Jet Grout Column 18 DSC Headwall	2	CMB-0156	Agree to Merit Agree to Cost	05/07/14	+12,060	While drilling down on column #18 at the UMS south headwall, BIHJV's subcontractor, CJA-NCC, encountered a hard unknown obstruction. 09/11/13 - Item reviewed at CMB mtg. during review of Trend/Change Log. 10/16/13 - DSC presented for merit approval - No action was taken by the CMB. The CM will investigate if the 1252 Contractor received the 1251 As built information by the start of operations. COR Rescinded. CLOSED; NO FURTHER ACTION
1252-0120	103	Retrieval Shaft Additional Slip Lining Pipe Qty	4				-0	RFI 251.1 SFMTA Response: Specification 33 31 00 1.01 A.22 Sewer Work, states, " Slip lining existing 3-foot by 5-foot brick sewer with 16-inch and 24-inch diameter HDPE Pipe (polyethylene pipe) nominal size SDR 26." As such, slip lining is to be performed for both the 16" and 24" diameter HDPE pipe. Branches indicated in the supplied sketch to be relined along Stockton and Columbus are acceptable. In addition, the 33-ft long branch that crosses the alignment at CTL 86+35 must also be relined. Acceptable alternative (to fused HDPE) pipe materials and sizes for this branch can be proposed by BIH. BIH shall submit the propose alternative for this branch of pipe for SFMTA review. The use of coupled PVC is not acceptable." 09/11/13 - Item viewed at CMB mtg. during review of weekly Trend/change log. No dwg for this work only a table. CM Team working with designer to make the determination. Item now being tracked under PCC 16. CLOSED; NO FURTHER ACTION
1252-0121	105	Retrieval Shaft Relocation of Seismograph	1				-0	BIHJV: "BIHJV's instrumentation subcontractor, Wang, was directed to relocate one of the vibration monitoring devices (Seismograph) installed at the Retrieval Shaft area to monitor vibration induced by demolition operations of the existing Pagoda Theater building." 09/11/13 item reviewed at CMB meeting during review of weekly Trend/Change log. CMB doesn't agree with the relocation charge and requested a better definition of the item. 01/22/14 - Item viewed at CMB as an status update. SFMTA letter No. 241 sent to Contractor denying merit. CLOSED; NO FURTHER ACTION
1252-0122	89	UMS - Suspended Remobilization of Jet Grout Rig	7				-0	BIHJV: "The SFMTA directed BIHJV/CJA-NCC to suspend the planned remobilization of the Jet Grout Rig at the UMS location due to external affairs with local UMS businesses." 09/11/13 - Item reviewed at CMB mtg. during review of weekly Trend/change log. CMB questioned the timeliness of the COR also requesting a better definition of the item. Item has been elevated to the Issue Resolution Ladder (IRL) process.
1252-0123	104	Retrieval Shaft - Additional Sewer Slip Lining 16" HDPE Pipe	4				-0	BIHJV: "BIHJV submitted RFI Nos. 275, 275.1 and 275.2 requesting clarification about specific sewer slip lining runs at the Retrieval Shaft, see Attachment Nos. 2, 4 and 6. The SFMTA responded, via RFI No. 275.2, stating that the slip lining is to be installed in a stacked configuration with the 24" over the 16" HDPE pipe, see Attachment No. 7. BIHJV and Synergy believe the SFMTA's response to install stacked HDPE slip lining pipes is additional work as the contract documents do not support this statement." 10/02/13 - Item reviewed at CMB mtg. during review of the weekly Trend/change log update. The CM states the DSC maybe eliminated. Waiting for a response from PUC now there is a as built condition. Letters are being written between SFMTA and SFPUC. 01/22/14 - Item viewed at CMB mtg as an update to potential cost exposure. CLOSED; NO FURTHER ACTION

- 1 - Owner Directed Change in Scope
- 2 - Unforeseen Conditions
- 3 - Errors and Omissions
- 4 - Quantity Variation
- 5 - Value Engineering
- 6 - Private Utilities
- 7 - Other

CENTRAL SUBWAY PROJECT
Project Trend/Change Control Log

Item #		Change Description	Change Type	CMB No.	Change Status		Projected Cost Impact +Exposure/(Benefit)	Comments	Contract Modification Number
					Approval Action	Approval Date	Actual/Forecast		
1252-0124		PCC 17 Green Street Sewer Changes	2		Agree to Merit	9/25/2013	-0	In preparation to beginning slip lining work at the intersection of Columbus/Green/Stockton, the Contractor performed a site investigation of the existing 3'x5' brick sewer. The Contractor discovered 4 unknown pipes intersecting the sewer. Received email from DPW on Oct 18 regarding proposed new direction to spray mortar sewer line in lieu of slip lining. DPW also requested additional slip lining on Columbus from Sta. 83+50 to Sta. 85+50. 09/25/13 - DSC presented for merit approval - Agreed. CMB directed the CM Team to ask the Contractor for recommendation to slip line as much of the sewer line as possible without rerouting the conflicting pipe lines. 01/22/14 - Item viewed at CMB mtg as a status update to projected cost exposure. Item will be tracked under PCC17.	
1252-0125		PCC 14 Modifications to AWSS Facilities at 4th and Bryant Streets	1				+35,925	Deletion of 12" AWSS diagonal sleeved pipe crossing and hydrant lateral. Installation of 12" AWSS restrained pipe and hydrant lateral. 10/16/13 - Draft PCC reviewed at CMB. The Board is in agreement with the modification. 10/23/13 - Engineers estimate for new work \$136,478 and deleted work (\$163,382) was presented to the CMB. PCC will be forwarded to the Contractor to price the work. In addition a cost estimate will be done for the work which would have been under the 1300 contract. 04/16/14 - CMB authorize the RE to negotiate with the Contractor for a amount up to \$35K.	
1252-0126	108	Ellis shaft and Old Navy Grouting	2				-0	BIHJV's subcontractor, CJA-NCC, claims to have discovered material (cemented zones) different than that described in the Geotechnical Baseline Report in the Ellis Shaft and Old Navy Grouting Zones. 10/23/13 - Item reviewed at CMB mtg. during review of weekly Trend/Change log. The CM stated this item will be rejected, due to a lack of information being supplied by the Contractor to validate the COR. SFMTA sent Letter No. 247 & 253 denying merit. CLOSED; NO FURTHER ACTION	
1252-0127a		FA CO 8 Remove and replace material at Retrieval Shaft CSM wall	1				+22,300	Contractor to remove hazardous material (approximately 250 CY) found in the footprint of the Retrieval Shaft Cutter Soil Mix (CSM) wall and replace with both clean material found on-site (approximately 190 CY) and import material (approximately 60 CY). 10/30/13 - Item reviewed at CMB during review of weekly Trend/Change log. Work to proceed on FA for a NTE amount of \$22,300. COMPLETE; NO FURTHER ACTION: CMOD #28	CMOD #28 Executed
1252-0127b		FA CO 8 Remove and replace material at Retrieval Shaft CSM wall					(6,339)	Approximate remaining balance of Executed CMod associated with FA CO 8. SFMTA current reconciled FA costs are \$15,961. Final CMod required to reconcile balance. See Trend 127a.	
1252-0128a		FA CO 7 Acceleration of Work Activities at Retrieval Shaft	1				+5,000	SFMTA to compensate BIHJV for premium time incurred on October 5th, 2013 to accelerate the completion of the site work and soundwall at the Retrieval Shaft. 11/06/13 - Item reviewed at CMB mtg. during review of weekly Trend/Change log. 01/22/14 - Item reviewed at CMB mtg as a status update to potential cost exposure. COMPLETE; NO FURTHER ACTION: CMOD #28	CMOD #28 Executed
1252-0128b		FA CO 7 Acceleration of Work Activities at Retrieval Shaft					(4,356)		
1252-0129		0 UMPs on 96-inch Sewer	2				-0	BIHJV's subcontractor Wang Technology claims to have encountered a DSC (brick structure) while drilling for utility monitoring points on Howard Street. 11/06/13 - Item reviewed at CMB mtg. during review of weekly Trend/Change log. CLOSED; NO FURTHER ACTION	

- 1 - Owner Directed Change in Scope
- 2 - Unforeseen Conditions
- 3 - Errors and Omissions
- 4 - Quantity Variation
- 5 - Value Engineering
- 6 - Private Utilities
- 7 - Other

CENTRAL SUBWAY PROJECT
Project Trend/Change Control Log

Item #	Change Description		Change Type	CMB No.	Change Status		Projected Cost Impact +Exposure/(Benefit)	Comments	Contract Modification Number	
					Approval Action	Approval Date	Actual/Forecast			
1252-0130	0	PCC 16	Ret Shaft Sewer Changes	2			-0-	BIHJV's subcontractor Synergy Project Management claims to have encountered the following DSCs while performing an investigation into planned slip lining work at the intersection of Columbus/Union/Powell: Internal clearance issues, unforeseen lateral connections, mixed debris and grease buildup inside sewer, and tighter radius than was anticipated for the planned junction structure. 11/20/13 - Item reviewed at CMB mtg. during review of weekly Trend/Change log. The Board suggested the CM Team ask the PUC to tell us what they would like the Contractor to do. 02/05/14 - FACO 10 was presented for consideration to add a 16" pipe. The CMB took no action. Direction was given to investigate the use of the pipe and to determine the most cost effective approach to reach PUC's desired equivalency of the 36" pipe removed. CLOSED; NO FURTHER ACTION		
1252-0131a	0	FA CO 9	Obstruction hit at CSM panel W6	2	CMB-0146	Agree to Merit Agree to Cost	12/11/13	+9,000	BIHJV's subcontractor Drill Tech claims to have encountered a DSC (unknown steel members) while performing Cutter Soil Mixing (CSM) on panel W6 at the Retrieval Shaft. 11/20/13 - Item reviewed at CMB mtg. during review of weekly Trend/Change log. This item will be tracked on FA. 12/11/13 - Merit evaluation presented to CMB - Agreed. EE presented for cost NOT TO EXCEED \$9,000 - Agreed COMPLETE; NO FURTHER ACTION: CMOD #28	CMOD #28 Executed
1252-0131b		FA CO 9	Obstruction hit at CSM panel W6	0				(2,073)		
1252-0132	COR 111	0	Material Hardness at Retrieval Shaft	2				+259,486	BIHJV's claims to have encountered ground material characteristics that are significantly harder than anticipated based on the information provided during the negotiations of PCC 10 (Relocation of Retrieval Shaft). 11/20/13 - Item reviewed at CMB mtg. during review of weekly Trend/Change log.	
1252-0133	0	PCC 15	Deleted AWSS Work at Union St and Columbus Ave	1				(187,181)	PCC 15 issued to: 1.) Delete all work associated with the removal and disposal of the Auxiliary Water Supply System (AWSS) utilities as shown on Contract Drawing No. AW-501.1 Rev.0. 2.) Delete all work associated with furnishing and installation of AWSS utilities as shown on Contract Drawing No. AW-501.9 Rev.0. Note: Monitoring of existing AWSS line to be performed in lieu of installation of new AWSS utilities. 12/11/13 - Item reviewed at CMB during review of weekly Trend/Change log. 02/19/14 - Cost revised based on Eng Est. and scoping meeting w/Contractor.	
1252-0134	0	PCC 18	Retrieval Shaft Site Supervision	1				-0-	PCC 18 issued to provide for the Contractor's supervision and engineering services during the compensation grouting activities at the Retrieval Shaft. 01/08/14 - Item reviewed at CMB meeting during review of weekly Trend/Change log. 01/29/14 - PCC presented for review. CMB agreed with change. CLOSED; NO FURTHER ACTION	
1252-0135	0		Retrieval Shaft Comp Grout Array 045 Obstruction	2				-0-	BIHJV's subcontractor, Drill Tech, encountered a concrete obstruction at the Retrieval Shaft location on December 17th, 2013 when performing survey layout of the design location for several of the comp grout holes in the 045 array. 01/08/14 - Item reviewed at CMB meeting during review of weekly Trend/Change log. The CM reported the Contractor will be notified there is no merit for this change request. SFMTA denial letter No. 270 sent to Contractor. CLOSED; NO FURTHER ACTION	
1252-0136	0		Installation of Piping, Conduit and Casing at Fourth Street Portal	1				TBD	PCC 19 issued to provide standpipe piping, telephone and train signal conduits, and casing at Fourth Street Portal. 02/26/14 CMB agreed on Jan. 29, 2014 with forwarding the PCC to the Contractor for pricing.	

- 1 - Owner Directed Change in Scope
- 2 - Unforeseen Conditions
- 3 - Errors and Omissions
- 4 - Quantity Variation
- 5 - Value Engineering
- 6 - Private Utilities
- 7 - Other

CENTRAL SUBWAY PROJECT
Project Trend/Change Control Log

Item #	Change Description	Change Type	CMB No.	Change Status		Projected Cost Impact +Exposure/(Benefit)	Comments	Contract Modification Number
				Approval Action	Approval Date	Actual/Forecast		
1252-0137	North Beach Sewer Work	1	CMB-0152	Agree to Cost	03/12/14	-0	Contractor directed to proceed with work on a Force Account basis for 'Sewer Work on Columbus and Powell St (North Beach)' in accordance with Force Account Change Order No. 010 03/12/14 CMB authorized a NTE amount of \$10,000 to start negotiations with the Contractor on the forthcoming PCC 20 for the price of the plates. Contractor's written cost for standby required to complete negotiations.	
1252-0138	Curb Ramp Work at NE Corner of 4th and Harrison Streets	1				+5,023	Contractor directed to proceed with work on a Force Account basis to install modified curb ramps and additional sidewalk flags in accordance with Force Account Change Order No. 011. 03/26/14 - CMB authorized a FACO NTE amount of \$4500., which will be reimbursed by PG&E through the form B process.	
1252-0139	BART - Additional Load Cells		CMB-0157	Agree to Merit Agree to Cost	05/07/14	+1,066	BIHJV: "In accordance with the SFMTA's direction, BIH is providing two new fully functional load cells (the same model as currently installed in the BART tunnels) as well as two new DTI Squirters (the same model as currently installed in the BART Tunnels). It is BIHJV understanding that the SFMTA may decide to replace load cells #M1-75A and #M2-75A currently installed in the BART existing tunnels with the instruments hereby provided by BIH-JV and that the replacement operation will occur without BIHJV technical support."	
1252-0140a	Installation of Water Pipe, Sewer, Bulb-outs, and Sidewalk Widening in North Beach					+567,534	PCC 20 includes: <ul style="list-style-type: none"> Furnish and install water piping for the San Francisco Water Department (SFWD) Furnish and install sewer catch pits, manholes, and piping for the San Francisco Public Utilities Commission (SFPU) Furnish and install additional sidewalk pavement (widening and bulb-outs), crosswalk ramps, curb, gutter, reinforced bus-pads, street base and pavement for the San Francisco Municipal Transportation Agency, Sustainable Streets Division (SFMTA) 05/14/14 - Item reviewed at CMB mtg. during review of weekly Trend/Change log. - CMod 36 will be issued for \$328,860K for install of water pipe.	
1252-0140b	Installation of Water Pipe					+328,860	Amount shown represents negotiated amount. Additional costs for 100' of pipe and DSC mitigation pending.	
1252-0141	SB Tunnel Material Conditions					-0	BIHJV claims to have encountered soil conditions different from those described in the GBR and Contract Documents on April 15, 2014, while excavating the Southbound (SB) tunnel. 05/14/14 - Item reviewed at CMB mtg. during review of weekly Trend/Change log. CLOSED; NO FURTHER ACTION	
1252-0142	Contract Milestone Changes					-0	Contract Modification to modify the sequencing of tunnel construction and cross passage construction. 05/14/14 - Item reviewed at CMB mtg. during review of weekly Trend/Change log.	
1252-0143	Columbus Ave. Waterline					+5,000	BIHJV claims their subcontractor Synergy encountered an unmarked waterline on Columbus Avenue while excavating to install the new 24" waterline for PCC 20 (Trend #140b). 06/04/14 - Item reviewed at CMB mtg. during review of weekly Trend/Change log.	
1252-0144	Installation of Geophones in NB and SB Tunnels					+5,000	FA CO 13 Includes: <ul style="list-style-type: none"> Installation of 1 geophone at STN 130+92 in the SB tunnel Installation of 1 geophone at STN 130+92 in the NB tunnel Allow the geo phones to read for an approximate 24hr period during active tunneling operations in each tunnel. Provide data gathered by geophones to SFMTA for review 06/04/14 - Item reviewed at CMB mtg. during review of weekly Trend/Change log.	
1252-0145	Excavation of Cross Passage No. 03					+50,000	BIHJV claims their subcontractor, Drill Tech, encountered material conditions which differ from the conditions described in the Geotechnical Baseline Report (GBR) and the Contract Documents during the excavation of Cross Passage 3. 06/25/14 - Item reviewed at CMB mtg. during review of weekly Trend/Change log. \$50K represents a CM Team estimate	

- 1 - Owner Directed Change in Scope
- 2 - Unforeseen Conditions
- 3 - Errors and Omissions
- 4 - Quantity Variation
- 5 - Value Engineering
- 6 - Private Utilities
- 7 - Other

CENTRAL SUBWAY PROJECT
Project Trend/Change Control Log

Item #	Change Description	Change Type	CMB No.	Change Status		Projected Cost Impact +Exposure/(Benefit)	Comments	Contract Modification Number
				Approval Action	Approval Date	Actual/Forecast		
1252-0146	Cross Passage No. 01					+50,000	BIHJV claims they encountered material conditions which may differ from the conditions described in the Geotechnical Baseline Report (GBR) and the Contract Documents during the dewatering operations of Cross Passage 1. \$50K represents a CM Team estimate	
Contract 1252 Totals						8,927,323	Total Changes and Potential Change (trends) to the contract are currently \$8,927,323 Out of Scope Changes to the Contract for Relocation of TBM (Trend 79, PCC 10) to be paid out of CPT690, funded separately. Not include in total above and being tracked separately from original Program Costs of \$1.5783B	
CONSTRUCTION TRENDS (Based on #1252 Trending Log and CMod) - SUBTOTALS:						8,927,323	The \$8,927,323 represents an UNDERRUN of allocated contingency. Current Balance = (23,658,463 - 8,927,323 = \$14,731,141 This does not include potential reimbursements from utilities.	
DESIGN TRENDS								
FD-001	084-0001	Narrowing of Platform at UMS	1	CMB-0006	Agree	08/04/10	(800,000)	[In "Current Forecast" - Sep2010 Cost Report.]
FD-002	084-0002	Redux of Station Emergency Ventilation Fans (UMS)	1	CMB-0009	Agree (Conditionally)	08/25/10	(2,000,000)	Further actions: Designer required to receive Fire/Life/Safety approval before proceeding with this change. Designer to allocate cost impacts by Station (Current figures are "place-holders.". [In "Current Forecast" - Sep2010 Cost Report.]
FD-002	085-0001	Redux of Station Emergency Ventilation Fans (CTS)	1	CMB-0009	Agree (Conditionally)	08/25/10	(500,000)	Further actions: Designer required to receive Fire/Life/Safety approval before proceeding with this change. Designer to allocate cost impacts by Station (Current figures are "place-holders.". [In "Current Forecast" - Sep2010 Cost Report.]
FD-002	086-0001	Redux of Station Emergency Ventilation Fans (MOS)	1	CMB-0009	Agree (Conditionally)	08/25/10	(500,000)	Further actions: Designer required to receive Fire/Life/Safety approval before proceeding with this change. Designer to allocate cost impacts by Station (Current figures are "place-holders.". [In "Current Forecast" - Sep2010 Cost Report.]
FD-003	085-0002	Lowering of CTS	1	To be verified	Info Only	08/25/10	+7,000,000	Presented to CMB for information/consideration.
FD-004	084-0003	UMS Structural Configuration	1	CMB-0007	Agree	08/18/10	(8,000,000)	[In "Current Forecast" - Sep2010 Cost Report.]
FD-005	084-0004	UMS Alternate Station Access/Vent Shaft @ Union Square	1	CMB-0010	Agree	12/29/10	(22,500,000)	Documentation to be filed.
FD-006	084-0005	Station Headwalls - UMS	1	CMB-0008	Agree	08/18/10	-0-	
FD-006	086-0002	Station Headwalls - MOS	1	CMB-0008	Agree	08/18/10	-0-	
FD-007		Cross-passages	1	CMB-0018	Agree	09/15/10	-0-	
FD-008		Trolley Re-route @ Columbus & Powell	1	CMB-0017	Agree	09/15/10	+2,000,000	
FD-009	082-0003	ECP to Modify Sidewalk Vault Demolition and Construction Sequence to Facilitate Construction of Joint Utilities Trench and Future UMS Station	1	CMB-0019	Agree	12/15/10	+3,000,000	
FD-010	082-0004	Redesign Stockton Street Sanitary Sewer to conform to SFPUC Sewer Criteria that preclude placement of relocated sanitary sewer under sidewalks	1	CMB-0020	Agree	11/17/10	+2,000,000	
FD-011	082-0005	Reconfigure Routing of Water, Sewer and Gas laterals from buildings on north side of Ellis Street	1	CMB-0021	Agree	11/17/10	+500,000	
FD-012	082-0006	Recognize cost transfers from design allowances allocated to contingency to explicit line items in final design estimates	1	CMB-0022	Disagree	11/17/10	-0-	
FD-013	082-0007	Increase Extent of Sub-sidewalks Vault Secondary Closure Walls and Waterproofing	1	CMB-0023	Agree	11/17/10	+4,100,000	

- 1 - Owner Directed Change in Scope
- 2 - Unforeseen Conditions
- 3 - Errors and Omissions
- 4 - Quantity Variation
- 5 - Value Engineering
- 6 - Private Utilities
- 7 - Other

CENTRAL SUBWAY PROJECT
Project Trend/Change Control Log

Item #	Change Description	Change Type	CMB No.	Change Status		Projected Cost Impact +Exposure/(Benefit)	Comments	Contract Modification Number
				Approval Action	Approval Date	Actual/Forecast		
FD-014	082-0008	Include OCS system for rerouting trolley buses to Fifth Street	1	CMB-0024	Agree	12/15/10	+3,100,000	
FD-015	082-0009	Subsidewalk Vault Secondary Closure Walls for Buildings at 800 Market and 838 Market	1	CMB-0025	Agree	11/17/10	+1,000,000	
FD-016	085-0003	Underpinning of Mandarin Tower	1	CMB-0011	over taken by FD-021	01/19/11	+5,000,000	Additional Information Pending.
FD-017	085-0004	CTS Ground Improvement	1	CMB-0012	over taken by FD-021	01/19/11	+10,300,000	Additional Information Pending.
FD-018	084-0006	UMS Apple Store Entrance	1	CMB-0013	Disagree	11/10/10	-0	Additional Information Pending.
FD-019	086-0003	MOS TOD Configuration	1	CMB-0014	Agree	11/10/10	TBD	
FD-020	084-0007	UMS Emergency Stair #4 Relocation	1	CMB-0015	Agree	11/10/10	TBD	
FD-021	085-0005	CTS Lowering and Stations Reconfiguration	1	CMB-0027	Agree	01/19/11	(18,000,000.00)	Agreement with changes to project configuration only. Additional Information required related to cost and schedule impacts. No agreement on Design cost impact, Design costs directly related to this change to be tracked separately
FD-022	084-0008	Sewer Replacement along Geary & O'Farrell	1	CMB-0029	Agree	02/23/11	(134,000)	This trend has both an EPC number as well as a Construction Trend Number. See also Construction Trend No. 1251-0003
FD-023	087-0001	Emergency walkways through crossover cavern changed from outside the main tracks to between the main tracks.	1	CMB-0032	Agree	07/27/11		
FD-024	087-0002	Diamond crossover on surface segment to a tandem (universal) crossover.	1	CMB-0033	Agree	08/24/11	(350,000)	
FD-025	083-0001	Bid Option for TBM Retrieval Shaft		CMB-0034	Agree	04/13/11	(10,000,000)	Will require changes to Bid Schedule to incorporate Traffic, Utilities and Pavement Demo/Restoration as incidental costs to the Bid Option. Estimated DP1 cost impact is approx. 80-100 hrs. of engineering time.
FD-026	084,085,086	Air Replenishment System for Stations	1	CMB-0040	Agree	07/13/11	+1,245,000	Install air replenishment system at MOS, CTS and UMS to address the requirements of the SFFD Bulletin 5.07. The air replenishment system will be used to fill firefighter's self-contained breathing apparatus during firefighting operations in the three subway stations.
FD-027	082-0010	1 Stockton street (Apple Store) Secondary Closure Wall		CMB-0043	Agree	08/03/11	+500,000	1) Add secondary closure wall to supplement recently completed primary closure wall built by owner to isolate the sub-sidewalk basement of 1 Stockton Street (Apple Store). 2) Modify position of joint trench (and all associated conduits, ducts etc.) for secondary closure wall to be constructed.
FD-028	086-0004	MOS Revisions to Emergency Ventilation Requirements		CMB-0052	Agree	09/07/11	+500,000	Changes will extend the date of the 90% (pre-final) submittal by 20 working days and the 100% (final) submittal by 40 working days. CMB did not approve a time extension for 90% or 100% submittal delivery. Project Controls estimated \$321,645.
FD-029	085-0006	CTS Revisions to Emergency Ventilation Requirements		CMB-0053	Agree	09/07/11	+1,000,000	Changes will extend the date of the 90% (pre-final) submittal by 20 working days and the 100% (final) submittal by 40 working days. CMB did not approve a time extension for 90% or 100% submittal delivery. Project Controls estimated \$411,895.
FD-030	084-0009	UMS Revisions to Emergency Ventilation Requirements		CMB-0054	Agree	09/07/11	+1,000,000	Changes will extend the date of the 90% (pre-final) submittal by 20 working days and the 100% (final) submittal by 40 working days. CMB did not approve a time extension for 90% or 100% submittal delivery. Project Controls estimated 733,420.
FD-031		Accessibility Improvements at the SE corner of Union Square (UMS)						
FD-032		Union Square Entrance Reconfiguration (UMS)						
FD-033		Additional Compensation Grouting due to Tunnel Settlement Alert and Trigger Levels (All Stations)					+21,040,000	ECP dated 11/17/11. ECP being routed for approval.
FD-034		Operational Performance and Safety Enhancement at 4th and King		CMB-0062	Agree	12/14/11	+450,000	SFMTA Operations requested that the design of the 4th & King tie-in work be expanded to include a number of improvements at the junction involving the turn-back area extending to the scissors crossover at 6th & King. SFMTA Ops confirmed that the requested changes result in an arrangement that is consistent with standard operation practices and therefore does not involve new or unacceptable risks. CS 1553 Memorandum No. 0081. Conditionally agreed upon verification/resolution of Buy America issue for the switches. 3/14/12: "Buy America" issue no longer applicable. Revised ECP element - remove H&K switch machines and replace with hydraulic/120V switch machines such as Nortrak or equal.

- 1 - Owner Directed Change in Scope
- 2 - Unforeseen Conditions
- 3 - Errors and Omissions
- 4 - Quantity Variation
- 5 - Value Engineering
- 6 - Private Utilities
- 7 - Other

CENTRAL SUBWAY PROJECT
Project Trend/Change Control Log

Item #	Change Description	Change Type	CMB No.	Change Status		Projected Cost Impact +Exposure/(Benefit)	Comments	Contract Modification Number
				Approval Action	Approval Date	Actual/Forecast		
FD-035	Tunnel Air Replenishment System		CMB-0071	Agree	07/11/12	+1,215,000	Design and construct a fire fighter air replenishment system for Central Subway tunnel as described in SF Fire Code 511.2, Bulletin 5.07 except as noted in the Central Subway Request for Approval of Variance for the ARS to SFFD on March 5, 2012, and subsequently approved by SFFD. Design Impact: ROM - \$215K Construction Impact: ROM - \$1M	
FD-036	Surface Segment Sewers - 4th St.		CMB-0072	Agree	07/18/12	+2,200,000	Replace current unreinforced brick crown from 1906 as it may not be able to withstand loading for construction of the CS trackway section. Reconstruct manholes between Brannan and King Streets as existing are in conflict with proposed rail. Replace service laterals and provide sleeves for future replacement. Additional potential scope option of \$1.5M-Sewer and \$2.3M-Force Main may be requested. If so, it will be Cost to SFPUC	
FD-037	Platform Display System Signs		CMB-0077	Agree (Conditionally)	08/29/12	+500,000	Modify Stations (Contracts 1253, 1254 and 1255) and Surface, Track and Systems (Contract 1256) technical specifications and drawings for the Platform Display System (PDS) to match the changes made to the PDS units being supplied under the Integrated Systems Replacement (ISR) Project, Contract No.1260. 08/29/12 - CMB agreement condition upon follow up action to evaluate procurement by CN1260	
FD-038	Elongated Sidewalk Bulb-out at Chinatown Station		CMB-0121	Agree	06/05/13	+36,000	CTS Sidewalk Bulb out (Southwest corner Stockton/Washington To bring the Central Subway Project - Chinatown Station in closer conformance with the City's General Plan, SF Planning Department in its May, 2012 GPR Letter (recommends) making design changes specifically the extension of the sidewalk bulb-out at Stockton Street to help create a "station plaza". This elongated bulbout on the southwest corner (SWC) of Stockton and Washington Streets in front of the station headhouse would also include bike racks, benches, trees and other landscape features. 06/05/13 - CSDG designer estimate cost is not a CS expense. Addl funding source will need to be establish by San Francisco Planning to support the investigation study Design Impact: Estimated Construction Cost ROM \$36,200 Construction Impact: Estimated ROM 97 Hrs.: DPW Pavement/Sidewalk Design Modification Estimated ROM 60 Hrs.: CSDG bus door/mirror/tree/bike rack coordination	
FINAL DESIGN TRENDS (Based on All ECPs) - SUBTOTALS						+4,902,000	Incorporated budget increases have been absorbed by allocated and unallocated funds and the program budget to date remains \$1,578,300,000.	
OTHER TRENDS								
X51-001	082-0001	1251 Revised estimate, escalation impact and contingency.	7			+9,532,314	Cost Transfer #0033 (Base \$\$), 0033a (Allocated Contingency), 0036 (Base \$\$ Escalation , 0036a (Allocated Contingency Escalation). [Sep2010 Cost Report]	BT-0033, BT-0033-A, BT0036, BT-0036-A
X51-002	082-0002	Form B Credit for 1251 Utilities	7			(7,697,949)	Reserve and Contingencies removed as per communications with PG&E. This is consistent with the 1250 utility agreement. [Cost Transfer #0034 - Aug2010 Cost Report].	BT-0034
X52-001	083-0001	1252-(TUN) Revised estimate, escalation impact and contingency	7			(2,165,462)	Cost Transfer #0035 (Base \$\$), 0035a (Allocated Contingency), 0037 (Base \$\$ Escalation , 0037a (Allocated Contingency Escalation). [Sep2010 Cost Report]	BT-0037, BT-0037-A
X03-001	003-0001	OEWD's Pilot Training Program	7			+75,000	Workforce training pilot program in conjunction with the City/County's Office of Economic and Workforce Development (OEWD). Provides specialized training to SF residents to perform tunneling work. Central Subway financial responsibility being investigated. Requires further clarification	
X53-001	084-0001	CS 155-2 (DP2) CBP4 - Construction Budget Adjustment YOY	7	CMB-0044	Agree	07/27/11	Adjust construction budget in Section 6 of Contract No. CS 155-2 to Year of Expenditure	
X53-002		Change UMS Advertise Date to April 4th, 2012					DP2 Designer's new proposed dates for Pre-Final and Final Design have pushed out Advertise Dates.	
X53-003	084-0002	CN1253 (UMS) Construction Budget Adjustment 90%				+55,720,600	CMB is currently vetting the 90% estimate of \$221,534,723 which represents a \$XX increase from the 65% base amount in 2010\$. Increase would deplete current YOY dollars and require use of unallocated contingency.	

- 1 - Owner Directed Change in Scope
- 2 - Unforeseen Conditions
- 3 - Errors and Omissions
- 4 - Quantity Variation
- 5 - Value Engineering
- 6 - Private Utilities
- 7 - Other

CENTRAL SUBWAY PROJECT
Project Trend/Change Control Log

Item #	Change Description	Change Type	CMB No.	Change Status		Projected Cost Impact +Exposure/(Benefit)	Comments	Contract Modification Number	
				Approval Action	Approval Date	Actual/Forecast			
X53-004	084-0002	Approve/Execute/Certify durations change for UMS Contract					Shortened the duration for Approve/Execute/Certify - UMS Contract from 40 to 24days to reflect an optimistic but doable duration for contractor submittals.		
X54-001	085-0001	CS 155-2 (DP2) CBP5 - Construction Budget Adjustment YOY	7	CMB-0045	Agree	07/27/11	Adjust construction budget in Section 6 of Contract No. CS 155-2 to Year of Expenditure		
X54-002		Change CTS Advertise Date to May 23rd, 2012		CMB-0061	Agree	12/28/11	DP2 Designer's new proposed dates for Pre-Final and Final Design have pushed out Advertise Dates.		
X54-003		Change CTS Advertise Date to February 8th, 2012					Change CTS Advertise Date from May 23, 2012 to February 8, 2012 (-74 working days)		
X54-005		Revisions to CTS Construction Schedule		CMB-0060	Agree	12/28/11			
X54-006	085-0002	CS 155-2 (DP2) CBP4 - Construction Budget Adjustment - allowed	7						
X55-001	086-0001	CS 155-2 (DP2) CBP6 - Construction Budget Adjustment YOY	7	CMB-0046	Agree	07/27/11	Adjust construction budget in Section 6 of Contract No. CS 155-2 to Year of Expenditure		
X55-002		Change MOS Advertise Date to June 25th, 2012					DP2 Designer's new proposed dates for Pre-Final and Final Design have pushed out Advertise Dates.		
X55-003		Change MOS Advertise Date to May 23rd, 2012					Change MOS Advertise Date from June 25, 2012 to May 23, 2012 (-22 working days)		
X55-004		Change MOS Advertise Date to Aug 20, 2012					Change MOS to August 20, 2012		
X56-001		Change STS Advertise Date to July 27th, 2012					DP2 Designer's new proposed dates for Pre-Final and Final Design have pushed out the Station's Advertise Dates. STS Advertise Date is staggered from Station's Advertise Dates.		
X56-002		STS Construction Schedule Revision for Equipment Procurement							
X56-003		Change STS Advertise Date to October 1, 2012					Change STS Advertise Date to October 1, 2012		
X40-001	028-0001	SFPUC CDD Updated Budgets	7		Authorized	+505,127	1250 SFPUC CDD Monthly Service Report Final & 1251 SFPUC CDD Estimate	BT-0172, BT-0177	
X80-001	071-0001	DP1: CS 155-1 Modifications No. 2 & 3	see Prof. Serv		Authorized	+560,585	Modification No. 2: \$395,584.59, Modification No. 3: \$165,000. Individual details listed in Professional Services. See trend 1551-0002,1551-0005 - 1551-0009	BT-0170, BT-0171, BT-0173	
X80-002	071-0002	DP1: CS 155-1 Modification No. 4	7		Authorized	+135,898	Modification No. 4: \$135,898 Individual details listed in Professional Services. See trends 1551-0010 - 1551-0014.	BT-0187	
X80-003	029-0001	Increase City Auditor Budget	7		Authorized	+50,220	Reduce unallocated Contingency to increase City Auditor budget as authorized in Budget Authorization #51.	BR#51, BT-0181	
X80-004	232-0001	Increase SFCTA Budget	7		Authorized	+20,000	Increase SFCTA budget per Budget Authorization #51 to conduct travel forecast (TEP CEQA Modeling) to satisfy PMO review and SFMTA Fleet Plan light rail vehicle.	BR #51, BT-0182	
X80-005	072-0001	DP2: CS 155-2 Modification No. 1	7		Authorized	+1,010,000	Modification No. 1: \$1,010,600 Individual details listed in Professional Services. See trends 1552-0002, 1552-0003 and 1552-0005.	BT-0194, BR#53	
X80-006	072-0002	DP2: CS 155-2 Exercised Options	see Prof. Serv		Authorized	+366,771	Individual details listed in Professional Services. See trends 1552-0001, 1552-0007 and 1552-0014.	BT-0023, BT-0194	
X80-007	151-0001	Operations SFMTA Transit Services			Authorized	+50,000	CSP request services to support and test OCS for 30/45 trolley reroute. Authorized per Budget Revision #53	BR #53, BT-0189	
X80-008	081-0001	SFMTA Safety, Training, Security & Enforcement Div PCOs	7		Authorized	+60,000	CSP request PCOs to support 1251 and 1252 construction for one year. Authorized \$60,000 per Budget Revision #45.	BR #45, BT-0190	
X80-009	016-0001	SFMTA Sustainable Streets 30 and 45 re-route	7		Authorized	-0-	CSP request services to support 30/45 trolley reroute. \$162,600 was reduced from DPT staffing plan budget.	BT-0188	
X80-010	073-0001	DP3: CS 155-3 Modification No. 1	7		Authorized	+152,882	Modification No. 1: \$152,882 Individual details listed in Professional Services. See trends 1553-0012 and 1553-0013.	BT-0203	
X80-011	073-0002	DP3: CS 155-3 Exercised Options	see Prof. Serv		Authorized	+1,026,398	Individual details listed in Professional Services. See trends 1553-0001 - 1553-0004, 1553-0006, 1553-0009 - 1553-0011, 1553-0014. Updated from \$971,686 to include Trend 1553-0014.	BT-0203	
X80-012	151-0002	OCS materials procured directly for work in reference to CN1251 CMOD#12.		CMB-0065	Agree	1/25/2012, 2/29/12	+126,149	See also Trend 1251-0023	
X80-013	073-0003	DP3: Provide Vibration Impact Analysis and Extend PC Support Technical and CSP Quality Manager	1				+133,906	Amend #2: Vibration Impact Analysis \$38,380 Amend #3: PC Support Tech \$34,483; Quality Manager - \$61,043	TBD

- 1 - Owner Directed Change in Scope
- 2 - Unforeseen Conditions
- 3 - Errors and Omissions
- 4 - Quantity Variation
- 5 - Value Engineering
- 6 - Private Utilities
- 7 - Other

CENTRAL SUBWAY PROJECT
Project Trend/Change Control Log

Item #	Change Description	Change Type	CMB No.	Change Status		Projected Cost Impact +Exposure/(Benefit)	Comments	Contract Modification Number
				Approval Action	Approval Date	Actual/Forecast		
X80-014	For combining the stations and track and systems into Contract 1300 (SSTS)	7					Combined all the Station and Track and Systems into one Contract. Removed the buffer float activities from the station to track and systems and overlapped work that can now be done concurrent.	
X80-015	Changing the Bid Opening date and condensing the Contract Duration for Contract 1300	7		Agree	11/14/12		Change bid opening to March 19, 2013 and reevaluated procurement durations, revised calendars for UMS Garage, revised production rates for steel. 11/14/13 CMB Agreed verbally to change @ Mtg #101	
X80-016	Change to Tunnel and CTS interface and buffer float Contract 1300 (SSTS)	7		Agree	01/23/13		Change (MPS) reducing the number of days currently in (from 550 calendar days from NTP to 450 calendar days) for the key interface between CTS and the tunnel completion. Reduced number of days will be issued as part of Add #3 of the 1300 contract. 1/23/13 CMB Agreed verbally to change @ Mtg #111.	
OTHER TRENDS (Based on Various Trends)						+59,662,439	Current Forecast reflects a net +3,537,933 unfavorable impact for all Other Trends.	
GRAND TOTALS						+73,491,762	Current Forecast reflects an estimated net +68,635,132 3 unfavorable exposure to the project to date. Incorporated budget increases have been absorbed by allocated and unallocated funds and the program budget to date remains \$1,578,300,000.	

PROFESSIONAL SERVICES TRENDS: The following trends are listed for administrative purposes. The dollar amounts are reflected in the "Other Trends" section of this log in the form of cost (budget) transfers - i.e. CCOP's. The total values indicated for each professional contract are for tracking all potential cost exposures and may or may not be approved.

Contract CS-155-1								
Item #	Change Description	Change Type	CMB No.	Approval Action	Approval Date	Projected Cost Impact +Exposure/(Benefit)	Comments	Contract Modification Number
1551-0001	Conform Contract Terms per Negotiations from 10/2/09 to 11/6/09	7				-0-	To be addressed in Amendment 1.	Amendment 1 Pending
1551-0002	Project Office Delay (Adjustments for OH Rate and Team Productivity impact)	7		Authorized	07/29/11	+101,411	Amendment Signed by ED/CEO 7/29/11 COMPLETE, NO FURTHER ACTION; Amendment #2	Amendment 2 Approved
1551-0003	Additional Construction Support for CP-1	7						
1551-0004	Redesign Required by Barney's and PUC for CP-2	7						
1551-0005	Archeological Monitoring 16.20.C1 (total)	7		Authorized	07/29/11	+197,173	Amendment Signed by ED/CEO 7/29/11 COMPLETE, NO FURTHER ACTION; Amendment #2	Amendment 2 Approved
1551-0006	Eyebolts	7		Authorized	07/29/11	+50,000	Amendment Signed by ED/CEO 7/29/11 COMPLETE, NO FURTHER ACTION; Amendment #2	Amendment 2 Approved
1551-0007	Secondary Closure Walls 800/838 Market	1		Authorized	07/29/11	+47,400	Amendment Signed by ED/CEO 7/29/11 COMPLETE, NO FURTHER ACTION; Amendment #2	Amendment 2 Approved
1551-0008	Delete Optional Tasks - Tasks 1-14	1				-0-	Deleted Options in the amount of (\$529,952) in Amendment has been reversed through Budget Authorization #50. COMPLETE, NO FURTHER ACTION; Amendment #2	Amendment 2 Approved
1551-0009	CTS Lowering	1		Authorized	12/08/11	+165,000	Amendment Signed by ED/CEO 12/8/11 COMPLETE, NO FURTHER ACTION; Amendment #3	Amendment 3 Approved
1551-0010	Modify Sidewalk Vault Demo ECP-FD009	7		Authorized	12/08/11	+39,311	Amendment Signed by ED/CEO 12/8/11 COMPLETE, NO FURTHER ACTION; Amendment #4	Amendment 4 Approved
1551-0011	Modify Stockton St. Sewer ECP-FD010	7		Authorized	12/08/11	+4,112	Amendment Signed by ED/CEO 12/8/11 COMPLETE, NO FURTHER ACTION; Amendment #4	Amendment 4 Approved
1551-0012	Reconfigure Utilities N. Side Ellis ECP-FD011	7		Authorized	12/08/11	+2,448	Amendment Signed by ED/CEO 12/8/11 COMPLETE, NO FURTHER ACTION; Amendment #4	Amendment 4 Approved
1551-0013	Extend SubSidewalk Closure Wall ECP-FD013	7		Authorized	12/08/11	+85,233	Amendment Signed by ED/CEO 12/8/11 COMPLETE, NO FURTHER ACTION; Amendment #4	Amendment 4 Approved
1551-0014	Reroute OCS to Fifth St. ECP-FD014	7		Authorized	12/08/11	+4,794	Amendment Signed by ED/CEO 12/8/11 COMPLETE, NO FURTHER ACTION; Amendment #4	Amendment 4 Approved
1551-0015	Retrieval Shaft Redesign - Sewer By Pass	7				+56,000	Awaiting documentation from Designer	
1551-0016	Design Measures for Settlement Protection	7				+99,000	Awaiting documentation from Designer	
1551-0017	Incorporate Headwalls MOS/UMS	1		Disagree at this time	11/01/11	+42,000	In letter dated November 1, 2011 DPM responded that until concurrence with DP2 on cost transfer or additional documentation, the requested change is denied.	

- 1 - Owner Directed Change in Scope
- 2 - Unforeseen Conditions
- 3 - Errors and Omissions
- 4 - Quantity Variation
- 5 - Value Engineering
- 6 - Private Utilities
- 7 - Other

CENTRAL SUBWAY PROJECT
Project Trend/Change Control Log

Item #	Change Description	Change Type	CMB No.	Change Status		Projected Cost Impact +Exposure/(Benefit)	Comments	Contract Modification Number
				Approval Action	Approval Date	Actual/Forecast		
1551-0018	071-0018	Prepare Utility Composite	-		Disagree	11/01/11	+50,000	DPM responded that Program does not agree in letter dated November 1, 2011.
1551-0019	071-0019	Incorporate Cross Passages	1		Disagree at this time	11/01/11	+43,000	In letter dated November 1, 2011 DPM responded that until concurrence with DP2 on cost transfer or additional documentation, the requested change is denied.
Contract CS-155-1 Total							+986,882	Of the total cost exposure shown, Contract Modifications and Authorized Option dollars have been absorbed by DP1 allocated contingency in the amount of \$696,483 of a total budget of \$705,000. Additional potential exposure is +\$391,411. Currently, overall contract value remains unchanged in the amount of \$6,500,000.
Contract CS-155-2								
1552-0001	072-0001	Optional Task 2.50 and Task 12.07	1		Authorized	05/06/10	+274,775	CS Letter 0473 from ED/CEO Optional Task 2.50 to support art enhancement activities NTE \$164,383 and Optional Task 12.07 to support design structures for Public Art NTE \$110,392.
1552-0002	072-0002	Expanded Hydraulic Testing at CTS	7		Authorized	07/01/10	+26,100	Estimated cost breakdown is included in the 7/1/10 letter from CSDG and includes signed approval by SFMTA. Amendment No. 1 authorized by ED/CEO on 12/21/11. COMPLETE, NO FURTHER ACTION; Amendment #1
1552-0003	072-0003	Additional Soil Borings at UMS Station - Task No. 3.10 Supplemental Investigations	7		Authorized	11/02/10	+34,500	Estimated cost breakdown is included in the 10/11/10 letter from CSDG and includes signed approval by SFMTA. Amendment No. 1 authorized by ED/CEO on 12/21/11. COMPLETE, NO FURTHER ACTION; Amendment #1
1552-0004	072-0004	MOS TOD White Paper Proposal	1				+33,847	Conceptual study will assess a potential high rise building at the Moscone station headhouse. Estimated cost breakdown is included in the 2/11/2011 letter from CSDG - On Hold .
1552-0005	072-0005	CTS - Alternate 5	7		Authorized	03/24/11	+950,000	CS Letter from DED dated 3/24/11 has agreed to a modification of \$950,000 for performing additional work. Amendment No. 1 authorized by ED/CEO on 12/21/11. COMPLETE, NO FURTHER ACTION; Amendment #1
1552-0006	072-0006	Audited Overhead Rate Adjustment for Year 2010 - Request for Amendment	7				-0-	Estimated cost of \$406,320 is included in the 6/28/11 letter from CSDG. See 1552-0006 Rev. 1 for most current estimate
1552-0007	072-0007	REVIT and CAD Support (to City Staff) Option to DP2 Contract (Optional Services Task 12.12)	1		Authorized	07/25/11	+79,200	CS Letter No. 0768 from ED/CEO dated 7/25/11 has authorized Optional Task 12.12 NTE \$79,200.
1552-0008	072-0008	MOS Revisions to Emergency Ventilation Requirements	-		Provide further Justification	09/07/11	-0-	CMB did not approve a \$60,000 proposed increase. Document References ECP FD028, CSDG letter dated 8/8/11. DPM responded that program does not agree in letter dated 10/17/11.
1552-0009	072-0009	CTS Revisions to Emergency Ventilation Requirements	-		Provide further Justification	09/07/11	-0-	CMB did not approve an \$80,000 proposed increase. Document References ECP FD029, CSDG letter dated 8/8/11. DPM responded that program does not agree in letter dated 10/17/11.
1552-0010	072-0010	UMS Revisions to Emergency Ventilation Requirements	-		Provide further Justification	09/07/11	-0-	CMB did not approve a \$100,000 proposed increase. Document References ECP FD030, CSDG letter dated 8/8/11. DPM responded that program does not agree in letter dated 10/17/11.
1552-0011	072-0011	Audited Overhead Rate Adjustment for Year 2010 - Request for Amendment - Rev. 1	7				+426,322	Estimated cost breakdown is included in the 8/17/11 letter from CSDG. This is a revision to the 6/28/11 letter and cost breakdown.
1552-0012	072-0012	Station Air Replenishment System	-		Disagree	10/17/11	+36,240	Estimated cost breakdown is included in the 8/23/11 letter from CSDG. DPM responded that program does not agree in letter dated 10/17/11.
1552-0013	072-0013	COR for Additional Services Related to MOS Constructability Review and Assessment of Alternatives	-				-0-	Cost charged to Task 2.70- part of base work
1552-0014	072-0014	Proposal for Additional Work to provide Structural Engineering Support (Optional Services)	1		Authorized Optional Task 12.01.C5 only	11/04/11	+35,724	Estimated cost breakdown is included in the 9/22/11 letter from CSDG. Referenced Optional Work Tasks 12.01.C5 and 12.07.C5 - Effort re-evaluated - proposed cost to be resubmitted. CS Letter No. 1232 dated 11/4/11 from Director of Transportation has authorized Optional Task 12.01.C5 for the amount of \$12,796.
Contract CS-155-2 Total							+1,896,708	Of the total cost exposure shown, Contract Modifications and Authorized Option dollars have been absorbed by DP2 allocated contingency in the amount of \$1,046,324 of a total budget of \$4,890,707. Overall contract value remains unchanged in the amount of \$39,949,959.

- 1 - Owner Directed Change in Scope
- 2 - Unforeseen Conditions
- 3 - Errors and Omissions
- 4 - Quantity Variation
- 5 - Value Engineering
- 6 - Private Utilities
- 7 - Other

CENTRAL SUBWAY PROJECT
Project Trend/Change Control Log

Item #	Change Description	Change Type	CMB No.	Change Status		Projected Cost Impact +Exposure/(Benefit)	Comments	Contract Modification Number	
				Approval Action	Approval Date	Actual/Forecast			
Contract CS-155-3									
1553-0001	073-0001	Authorization to commence optional tasks 9.20J Technical Specifications Item J Facility SCADA	1		Authorized	08/01/11	+259,305	SFMTA letter 0933 from ED/CEO dated 8/9/11 authorizing \$738,787 in optional tasks. COMPLETE, NO FURTHER ACTION; OPTION	Option
1553-0002	073-0002	ation to commence optional tasks 12.05 Architecture	1		Authorized	08/01/11	+257,129	SFMTA letter 0933 from ED/CEO dated 8/9/11 authorizing \$738,787 in optional tasks. COMPLETE, NO FURTHER ACTION; OPTION	Option
1553-0003	073-0003	Authorization to commence optional tasks 12.13J Facility SCADA Design	1		Authorized	08/01/11	+169,553	SFMTA letter 0933 from ED/CEO dated 8/9/11 authorizing \$738,787 in optional tasks. COMPLETE, NO FURTHER ACTION; OPTION	Option
1553-0004	073-0004	Authorization to commence optional tasks 12.12E traction power cables for CAD production	1		Authorized	08/01/11	+52,800	SFMTA letter 0933 from ED/CEO dated 8/9/11 authorizing \$738,787 in optional tasks. COMPLETE, NO FURTHER ACTION; OPTION	Option
1553-0005	073-0005	Proposal to hire Wilson Ibrig to support Acoustics, Noise and Vibration tasks.	7		Authorized	03/08/12	+38,380	Signed by Director of Transportation 3/8/2012. COMPLETE, NO FURTHER ACTION ; Amendment 2	Amendment 2 Approved
1553-0006	073-0006	Proposal to exercise optional task 12.07 Public Art.	1		Authorized	11/04/11	+10,285	Letter dated 9/22/11 to DOM. PMCM response pending. Priced level of Effort assumed for this task. SFMTA Letter 1213 from Director of Transportation dated 11/4/11 authorizing optional task.	
1553-0007	073-0007	Proposal to exercise optional sub-task 12.12 structural design of the OCS attachments.	7				+59,460	Letter dated 9/27/11 to DOM. NOT FOLLOWING CONTRACT REQUIREMENTS FOR PROPER NOTIFICATION OF CHANGE. PMCM has responded to clarify scope in stations and Tunnel Design. Awaiting resubmittal of request by DP3	
1553-0008	073-0008	Scope Clarification - Add Emergency and Location Signage.	7		Disagree A.12.08- Signage	11/09/11		Letter dated 10/5/11 to DOM. NOT FOLLOWING CONTRACT REQUIREMENTS FOR PROPER NOTIFICATION OF CHANGE. CS Memo No. 0882 from DOM to DP3 PM considers A.12.08 Signage as part of the work necessary to complete the trackway elements of the scope. The work in question is considered part of the base scope of services.	
1553-0009	073-0009	Proposal to exercise mechanical optional task A 12.11 to design a water line on the FBS station platform.	1		Authorized	11/04/11	+33,000	SFMTA Letter 1213 from Director of Transportation dated 11/4/11 authorizing optional task. COMPLETE, NO FURTHER ACTION; OPTION	Option
1553-0010	073-0010	Proposal to exercise Task 12.01 Surface Segment site Drainage	1		Authorized	11/04/11	+108,240	SFMTA Letter 1213 from Director of Transportation dated 11/4/11 authorizing optional task. COMPLETE, NO FURTHER ACTION; OPTION	Option
1553-0011	073-0011	Proposal to exercise Task 12.02 Sewer Relocation and Analysis Report.	1		Authorized	11/04/11	+81,374	SFMTA Letter 1213 from Director of Transportation dated 11/4/11 authorizing optional task. COMPLETE, NO FURTHER ACTION; OPTION	Option
1553-0012	073-0012	CTS - Alternate 5	7		Authorized	01/18/12	+88,855	Contract Modification No. 1 authorized by ED/CEO on 1/18/12 COMPLETE, NO FURTHER ACTION; Amendment #1	Amendment 1 Approved
1553-0013	073-0013	Proposal for Geotechnical Services	7		Authorized	01/18/12	+64,027	Letter dated October 7, 2011 to DOM. PM/CM response pending. Contract Modification No. 1 authorized by ED/CEO on 1/18/12 COMPLETE, NO FURTHER ACTION; Amendment #1	Amendment 1 Approved
1553-0014	073-0014	Authorization to commence optional tasks 12.12E traction power cables for CAD production, Optional task 2.50 Coordination with Art			Authorized	02/06/12	+54,712	SFMTA Letter 1381 from Director of Transportation dated 2/06/12 authorizing optional tasks 12.12e in the amount of \$41,280 and 2.50 for \$13,432 COMPLETE, NO FURTHER ACTION; OPTION	Option
1553-0015	073-0015	Proposal for additional services in Response to Approved (ECP) FD-034 Operation Performance and Safety Enhancements to 4th and King and 6th and King.	1				+26,026	FD-034 was updated by CMB on 3/14/12. Proposal transmitted via letter CS1553 No. 0012 dated 3/20/12 to DOM. Amendment #4 PENDING	Option
1553-0016	073-0016	Proposal for additional work - Tunnel Air Replenishment System (Exercise Optional Service)	7		Authorized	04/26/12	+173,119	SFMTA letter 1658 from Director of Transportation dated 4/26/2012 authorizing \$173,119 in optional tasks. Included in FD-035 to be presented to CMB on 6/26/12	Option
1553-0017	073-0017	Extension of PC Support Technician	1		Authorized	05/04/12	+34,483	Signed by Director of Transportation 5/14/12 COMPLETE, NO FURTHER ACTION; Amendment #3	Amendment 3 Approved
1553-0018	073-0018	Extension of CSP Quality Manager	1		Authorized	05/04/12	+61,043	Signed by Director of Transportation 5/14/12 COMPLETE, NO FURTHER ACTION; Amendment #3	Amendment 3 Approved
1553-0019	073-0019	Authorization to commence optional task 12.02 Utility Plans for design of repositioned and reconstructed manholes for the 78 inch diameter sewer on 4th St.	1		Authorized	04/09/12	+52,712	SFMTA Letter 1630 from the Director of Transportation dated 4/9/2012 authorizing optional task 12.02 in the amount of \$52,712 COMPLETE, NO FURTHER ACTION; OPTION	Option

- 1 - Owner Directed Change in Scope
- 2 - Unforeseen Conditions
- 3 - Errors and Omissions
- 4 - Quantity Variation
- 5 - Value Engineering
- 6 - Private Utilities
- 7 - Other

CENTRAL SUBWAY PROJECT
Project Trend/Change Control Log

Item #	Change Description	Change Type	CMB No.	Change Status		Projected Cost Impact +Exposure/(Benefit)	Comments	Contract Modification Number	
				Approval Action	Approval Date	Actual/Forecast			
1553-0020	073-0020	Authorization to commence optional task 12.12 civil and structural support for traction power duct banks	1		Authorized	04/09/12	+109,000	SFMTA Letter 1630 from the Director of Transportation dated 4/9/2012 authorizing optional task 12.12 in the amount of \$109,000 COMPLETE, NO FURTHER ACTION; OPTION	Option
1553-0021	073-0021	Authorization to commence optional task 12.11 design of the tunnel based Air Replenishment System including fill panels, feeder pipes, gauges, valves, fire proofing, anchors, supports, low level alarms, wiring, signage, connections to SCADA and monitoring devices, equipment placement, and impact protection	1		Authorized	04/26/12	+173,119	SFMTA Letter 1658 from the Director of Transportation dated 4/26/2012 authorizing optional task 12.11 in the amount of \$173,119 COMPLETE, NO FURTHER ACTION; OPTION	Option
1553-0022	073-0022	Increased authorization for optional task 12.12.e CAD production support	1		Authorized	04/26/12	+30,000	SFMTA Letter 1658 from the Director of Transportation dated 4/26/2012 authorizing the increase in optional task 12.12e in the amount of \$30,000 COMPLETE, NO FURTHER ACTION; OPTION	Option
1553-0023	073-0023	Authorization to commence option task 12.11 structural design support for Fire Protection and Plumbing designs	1		Authorized	05/21/12	+39,204	SFMTA Letter 1688 from the Director of Transportation dated 5/21/2012 authorizing the increase in optional task 12.11 in the amount of \$39,204 COMPLETE, NO FURTHER ACTION; OPTION	Option
1553-0024	073-0024	Authorization to commence optional task 12.12 structural design support for Traction Power and Power/Lighting designs	1		Authorized	05/21/12	+43,638	SFMTA Letter 1688 from the Director of Transportation dated 5/21/2012 authorizing the increase in optional task 12.12 in the amount of \$43,638 COMPLETE, NO FURTHER ACTION; OPTION	Option
1553-0025	073-0025	Authorization to commence optional task 12.13 structural design support for Telephone and CCTV designs	1		Authorized	05/21/12	+24,328	SFMTA Letter 1688 from the Director of Transportation dated 5/21/2012 authorizing the increase in optional task 12.13 in the amount of \$24,328 COMPLETE, NO FURTHER ACTION; OPTION	Option
1553-0026	073-0026	Authorization to commence optional task 9.20 Technical Specifications for structural design support for above designs	1		Authorized	05/21/12	+3,039	SFMTA Letter 1688 from the Director of Transportation dated 5/21/2012 authorizing the increase in optional task 9.20 in the amount of \$3,039 COMPLETE, NO FURTHER ACTION; OPTION	Option
Contract CS-155-3 Total							7,814,010.46	Of the total cost exposure shown, Contract Modifications and Authorized Option dollars have been absorbed by DP3 allocated contingency in the amount of \$1,168,995 of a total budget of \$4,598,725. Overall contract value remains unchanged in the amount of \$19,919,526.	

- 1 - Owner Directed Change in Scope
- 2 - Unforeseen Conditions
- 3 - Errors and Omissions
- 4 - Quantity Variation
- 5 - Value Engineering
- 6 - Private Utilities
- 7 - Other